

ATP
Air Tools & Parts

ZAT
Impact Sockets

Thor's
Construction Tools

THAXTON
Hydrostatic Test Plugs

QUALITY GEAR
Custom Gears

Pneumatic Tools. Parts. Motors. Accessories.



Divisions of: **HY-TECH**
ENGINEERED SOLUTIONS



ATP

**Super Duty Industrial
Pneumatic Tools,
Parts and Accessories
Since 1923**

⊕ ZAT

**Super Strength Impact
Sockets, Striking Wrenches
and Accessories
Since 1969**

Thor

**Legendary Construction
Air Tools Since 1886**

THAXTON

**High Pressure
Hydrostatic Test Plugs
thaxtonplugs.com**

About **HY-TECH** *ENGINEERED SOLUTIONS*

Hy-Tech started manufacturing air tool parts in Pittsburgh, PA in 1923. Our products under the brand names of **ATP, Ozat, Thor and Thaxton** are sold in the U.S. and international markets.

We manufacture over **20,000** replacement parts offering the highest quality alternative to OEM parts and tools for many recognized brand names such as Ingersoll Rand, Chicago Pneumatic, Cleco, Top Cat and others. All parts and Ozat sockets, striking wrenches and accessories are backed by our lifetime warranty against defects in material and workmanship. Our tools have a one year warranty against defects in material and workmanship.

Hy-Tech's manufacturing capabilities include the following:

- Specialize in small to mid-size precision component manufacturing
- 5-axis machining capability
- A combination of 100 CNC and manual machines
- In house gear design with cutting, broaching, shaping, and hobbing capabilities
- 3D solid modeling design software
- Dynamometer for motor performance testing
- In house certified welding capabilities
- High capability vendors for heat treating, plating, and castings (sand, investment, and die) within a 90 mile radius of our plant
- Full turn key supplier capabilities

Additional company information can be viewed at www.hy-techinc.com

HY-TECH
ENGINEERED SOLUTIONS

25 Leonberg Road • Cranberry Township, PA 16066
Phone: 1-800-245-1148 • Fax: 724-776-0227

Product Contents



ATP Impact Tools **1**
 Super Duty 1/2", 3/4", 1", 1-1/2", 2-1/2",
 3-1/2", #4 & #5 Spline Models



ATP Abrasive Tools **9**
 Die Grinders & Angle Grinders
 Large Vertical and Horizontal Grinders



ATP Percussive Tools **16**
 Chipping Hammers, Rammers and Scalers

Thor Construction Tools **19**
 Paving Breakers, Clay Diggers, Rivet Busters
 and Backfill Tampers,



ATP Industrial Air Products **22**
 Centrifugal Sump Pump, Hoists, Drills,
 Air Motors

ATP Air Ventilators **28**
 Jet Air Fan and Venturi "Air Horns"



Air Tool Accessories **30**
 Blue Magic Oil, Pure Gold Grease, In-line
 Oilers, Whip Hoses, Moisture Separator,
 Couplings, Replacement Parts, Tune-up Kits



Ozat **36**
 1/2" to 3-1/2" Square Drive Impact Sockets
 #4 & #5 Spline Drive Sockets
 Adapters, Universals, Extensions & Ret Rings
 Hex Driver Sockets; 1 Piece & 2 Part Inhex
 Flat & Offset Striking Wrenches
 Torque Multipliers



Thaxton **84**
 High Pressure Hydrostatic Test Plugs

Quality Gear **87**
 Custom Gear Manufacturing





The World's Most Extensive Line of Super Duty Impact Tools

Impact tools provide rotary motion from an air motor to an impact mechanism, delivering a series of impacting blows to apply torque to a threaded fastener.

Impact tools do not transmit torque reaction back to the operator enabling fasteners to be safely tightened to high torque values. Torque output is determined by the size of the tool, air pressure and SCFM, and the length of time the tool is impacting on the fastener.

Impact Tool Applications

Impact tools are used in applications in refineries, petrochemical plants, power generation plants, railroads, paper mills, heavy off-road equipment repair, mining, steel mills, steel fabrication and structural steel erection.

ATP Impact Mechanism / Clutch Basics

Twin Hammer:

Twin hammers strike balanced blows for more torque per pound than other mechanism designs. This simplified design performs well on both hard and soft draw applications, is less sensitive to air pressure changes, and has lower cost of maintenance.

Single "Jumbo" Hammer:

The single hammer mechanism performs similarly to the Twin Hammer, but uses a single hammer in operation.

Ball and Cam:

The precision ball and cam mechanism used in larger high output impact tools delivers powerful rotary impacts for high output and durability, and is ideal for soft draw applications.

Two Jaw:

The two jaw clutch delivers high energy per blow torque output with a high power to weight ratio. Excellent choice for tough MRO and assembly applications. Very good on soft and hard draw applications.

Model Nomenclature References:

PT = Pistol Grip/Trigger	TH = Through Hole Square Drive
EI = End Grip/Inside Trigger	5S = 5 Spline
EO = End Grip/Outside Trigger	RR = Ring Retainer
LT = Lever Throttle	1H = 1" Square Through Hole

Example:

ATP 7560PT-TH = 3/4" drive, pistol grip, through hole anvil.

Where Impact Tool Models are Referenced:

- CP is a registered trademark of Chicago Pneumatic
- IR is a registered trademark of Ingersoll Rand

Lever Throttle

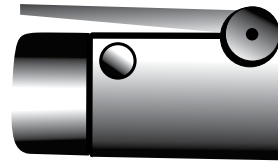

End Grip Outside Trigger



Pistol Grip

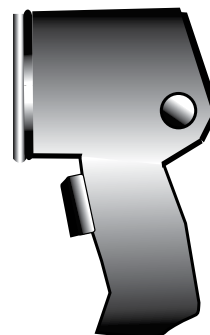

End Grip Inside Trigger



Spline Drive



Square Drive

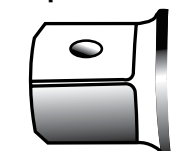

Impact Tool Selection Guide

The Best Impact Tools are Easy to Choose

The impact tool selection guide makes it easy to choose the correct tool for your applications.

1/2" - 3/4" Bolt Capacity (16mm - 19mm)

Model Series	Torque Range ft lb (Nm)*	Page
50PT	275 (373) - 450 (610)	3
7560	560 (760) - 1,025 (1,389)	3
7520	800 (1,085) - 1,100 (1,491)	3
7525	1,100 (1,492) - 1,600 (2,169)	3

1" - 1-3/8" Bolt Capacity (25mm - 35mm)

Model Series	Torque Range ft lb (Nm)*	Page
1011	1,800 (2,440) - 2,800 (3,796)	4
1034	1,100 (1,491) - 1,600 (2,169)	5
1034B9	500 (678) - 750 (1,000)	5
1040	1,600 (2,169) - 2,000 (2,711)	5
1041	1,650 (2,240) - 2,500 (3,390)	6
1042	1,900 (2,576) - 3,200 (4,338)	6

1-3/8" - 1-1/2" Bolt Capacity (35mm - 38mm)

Model Series	Torque Range ft lb (Nm)*	Page
1550	2,500 (3,400) - 3,000 (4,067)	7
1552	3,300 (4,474) - 4,000 (5,424)	7
1520	2,500 (3,400) - 3,000 (4,067)	7

1-1/2" - 4" Bolt Capacity (38mm - 102mm)

Model Series	Torque Range ft lb (Nm)*	Page
1578	5,500 (7,456) - 10,000 (13,560)	8
1580	5,900 (8,000) - 13,560 (18,383)	8
2582	10,000 (13,560) - 20,000 (27,114)	8
2588	25,000 (33,892) - 50,000 (67,784)	8
3599	42,000 (57,000) - 80,000 (108,500)	8

* Torque Range = Working Torque - Max Torque

Super Duty 1/2" & 3/4" Class Impact Tools



3/4" models available with 1" and #4 Spline Drives



50PT-PR



7560PT-TH



7520PT-1H



7525PT-TH

1/2" - 3/4" Bolt Capacity (16mm - 19mm)

Models	Working Torque ft lb (Nm)	Max Torque ft lb (Nm)	Handle Type	Drive Size	Socket Retainer	Length in (mm)	Weight lb (kg)	Air Inlet / Hose ID in (mm)	Comparable To
50PT-PR	275 (373)	450 (610)	Pistol Grip	1/2" Sq.	Pin & Ring Combo	6-13/16 (172.7)	5.6 (2.5)	1/4 NPT 3/8 (10)	IR2707P1
7560PT-TH	560 (760)	1,000 (1,356)	Pistol Grip	3/4" Sq.	Through Hole	7-5/8 (193)	11.6 (5.2)	3/8 NPT 1/2 (13)	CP6060-SASAB
7560PT-1H	575 (780)	1,025 (1,389)	Pistol Grip	1" Sq.	Through Hole	7-5/8 (193)	11.7 (5.3)	3/8 NPT 1/2 (13)	CP6060-SASAK
7560PT-RR	560 (760)	1,000 (1,356)	Pistol Grip	3/4" Sq.	Ring Retainer	7-5/8 (193)	11.6 (5.2)	3/8 NPT 1/2 (13)	CP6060-SASAR
7560PT-4S	575 (780)	1,025 (1,389)	Pistol Grip	#4 Spline	Button	7-5/8 (193)	11.7 (5.3)	3/8 NPT 1/2 (13)	CP6060-SASAL
7520PT-TH	800 (1,085)	1,100 (1,491)	Pistol Grip	3/4" Sq.	Through Hole	12-1/2 (317.5)	12 (5.4)	3/8 NPT 1/2 (13)	IR2920P1
7520PT-1H	800 (1,085)	1,100 (1,491)	Pistol Grip	1" Sq.	Through Hole	12-1/2 (317.5)	12 (5.4)	3/8 NPT 1/2 (13)	IR2920P3
7525PT-TH	1,100 (1,492)	1,450 (1,966)	Pistol Grip	3/4" Sq.	Through Hole	8-15/16 (226)	12.5 (5.6)	3/8 NPT 1/2 (13)	IR2925P1Ti
7525PT-1H	1,100 (1,492)	1,450 (1,966)	Pistol Grip	1" Sq.	Through Hole	8-15/16 (226)	12.5 (5.6)	3/8 NPT 1/2 (13)	IR2925P3Ti
7525RB-TH*	1,400 (1,898)	1,600 (2,169) rev	Pistol Grip	3/4" Sq.	Through Hole	8-15/16 (226)	12.5 (5.6)	3/8 NPT 1/2 (13)	IR2925RBP1Ti
7525RB-1H*	1,400 (1,898)	1,600 (2,169) rev	Pistol Grip	1" Sq.	Through Hole	8-15/16 (226)	12.5 (5.6)	3/8 NPT 1/2 (13)	IR2925RBP3Ti
7525PT-4S	1,100 (1,492)	1,450 (1,966)	Pistol Grip	#4 Spline	Button	8-15/16 (226)	12.5 (5.6)	3/8 NPT 1/2 (13)	IR2925P/#4 Spline

* Reverse Bias Power Models. All models available with extended anvil. Contact ATP Customer Service for more information. See Ozat Sockets starting on page 36. Socket retaining accessories are provided for all sockets in the Ozat section.

Super Duty 1" Drive Class Impact Tools

Available with #5 Spline Drive



1011PT-TH

1011 Series

- Two jaw clutch transfers high power
- Three piece housing for ease of repair
- Steel housing clutch design
- Integral muffler for noise reduction
- Great power to weight ratio
- Great for hard and soft draw applications



1011EI-5S

1" - 1-3/8" Bolt Capacity (25mm - 35mm)

Models	Working Torque ft lb (Nm)	Max Torque ft lb (Nm)	Handle Type	Drive Size	Socket Retainer	Length in (mm)	Weight lb (kg)	Air Inlet / Hose ID in (mm)	Comparable To
1011PT-TH	1,800 (2,440)	2,800 (3,796)	Pistol Grip	1" Sq.	Through Hole	10-11/16 (271.7)	23.1 (10.4)	1/2 NPT 3/4 (19)	CP0611-PRS
1011PT-5S	1,800 (2,440)	2,800 (3,796)	Pistol Grip	#5 Spline	Button	10-11/16 (271.7)	23.1 (10.4)	1/2 NPT 3/4 (19)	CP0611
1011EI-TH	1,800 (2,440)	2,800 (3,796)	End Grip I-T	1" Sq.	Through Hole	12-1/2 (317.5)	22.5 (10.2)	1/2 NPT 3/4 (19)	CP0611-PASED
1011E0-TH	1,800 (2,440)	2,800 (3,796)	End Grip O-T	1" Sq.	Through Hole	12-1/2 (317.5)	22.5 (10.2)	1/2 NPT 3/4 (19)	CP0611-GASED
1011EI-5S	1,800 (2,440)	2,800 (3,796)	End Grip I-T	#5 Spline	Button	12-1/2 (317.5)	22.5 (10.2)	1/2 NPT 3/4 (19)	CP0611-PASEL
1011E0-5S	1,800 (2,440)	2,800 (3,796)	End Grip O-T	#5 Spline	Button	12-1/2 (317.5)	22.5 (10.2)	1/2 NPT 3/4 (19)	CP0611-GASEL

All models available with extended anvil. Contact ATP Customer Service for more information.

See Ozat Sockets starting on page 36. Socket retaining accessories are provided for all sockets in the Ozat section.

Super Duty 1" Drive Class Impact Tools

Available with #5 Spline Drive



1034EI-THB9

1034 & 1040 Series

- High output twin hammer mechanisms
- Bronze end plates for increased motor durability
- Integral muffler for noise reduction
- Steel hammer case
- Three piece housing for ease of repair
- Available in pistol grip and end grip models



1040EI-TH

1" - 1-3/8" Bolt Capacity (25mm - 35mm)

Models	Working Torque ft lb (Nm)	Max Torque ft lb (Nm)	Handle Type	Drive Size	Socket Retainer	Length in (mm)	Weight lb (kg)	Air Inlet / Hose ID in (mm)	Comparable To
1034EI-TH	1,100 (1,491)	1,500 (2,034)	End Grip I-T	1" Sq.	Through Hole	11-1/4 (285.7)	19 (8.6)	1/2 NPT 3/4 (19)	IR2934B2
1034EO-TH	1,100 (1,491)	1,500 (2,034)	End Grip O-T	1" Sq.	Through Hole	11-1/4 (285.7)	19 (8.6)	1/2 NPT 3/4 (19)	IR2934A2
1034EI-5S	1,100 (1,491)	1,600 (2,169)	End Grip I-T	#5 Spline	Button	11-1/4 (285.7)	19 (8.6)	1/2 NPT 3/4 (19)	IR2934B1
1034EO-5S	1,100 (1,491)	1,600 (2,169)	End Grip O-T	#5 Spline	Button	11-1/4 (285.7)	19 (8.6)	1/2 NPT 3/4 (19)	IR2934A1
1034EI-THB9	500 (678)	750 (1,000)	End Grip I-T	1" Sq.	Through Hole	18-3/4 (476.2)	35.7 (16.1)	1/2 NPT 3/4 (19)	IR2934B9
1040PT-TH	1,600 (2,169)	2,000 (2,711)	Pistol Grip	1" Sq.	Through Hole	9-7/8 (250.9)	24 (10.8)	1/2 NPT 3/4 (19)	IR2940P2
1040PT-5S	1,600 (2,169)	2,000 (2,711)	Pistol Grip	#5 Spline	Button	9-7/8 (250.9)	24 (10.8)	1/2 NPT 3/4 (19)	IR2940P1
1040EI-TH	1,600 (2,169)	2,000 (2,711)	End Grip I-T	1" Sq.	Through Hole	12-7/16 (314.9)	24 (10.8)	1/2 NPT 3/4 (19)	IR2940B2
1040EO-TH	1,600 (2,169)	2,000 (2,711)	End Grip O-T	1" Sq.	Through Hole	12-7/16 (314.9)	24 (10.8)	1/2 NPT 3/4 (19)	IR2940A2
1040EI-5S	1,600 (2,169)	2,000 (2,711)	End Grip I-T	#5 Spline	Button	12-7/16 (314.9)	24 (10.8)	1/2 NPT 3/4 (19)	IR2940B1
1040EO-5S	1,600 (2,169)	2,000 (2,711)	End Grip O-T	#5 Spline	Button	12-7/16 (314.9)	24 (10.8)	1/2 NPT 3/4 (19)	IR2940A1

All models available with extended anvil. Contact ATP Customer Service for more information.
See Ozat Sockets starting on page 36. Socket retaining accessories are provided for all sockets in the Ozat section.

Super Duty 1" Drive Class Impact Tools

Available with #5 Spline Drive



High Output Impact Tool Series

1041 & 1042 Series

- High output twin hammer mechanisms
- Bronze end plates for increased motor durability
- High output 7 vane motor
- Steel hammer case
- Integral muffler for noise reduction
- Three piece housing for ease of repair



1" - 1-3/8" Bolt Capacity (25mm - 35mm)

Models	Working Torque ft lb (Nm)	Max Torque ft lb (Nm)	Handle Type	Drive Size	Socket Retainer	Length in (mm)	Weight lb (kg)	Air Inlet / Hose ID in (mm)	Comparable To
1041EI-TH	1,650 (2,240)	2,500 (3,390)	End Grip I-T	1" Sq.	Through Hole	11-1/4 (285.7)	19 (8.6)	1/2 NPT 3/4 (19)	IR3940B2Ti
1041E0-TH	1,650 (2,240)	2,500 (3,390)	End Grip O-T	1" Sq.	Through Hole	11-1/4 (285.7)	19 (8.6)	1/2 NPT 3/4 (19)	IR3940A2Ti
1041EI-5S	1,650 (2,240)	2,500 (3,390)	End Grip I-T	#5 Spline	Button	11-1/4 (285.7)	19 (8.6)	1/2 NPT 3/4 (19)	IR3940B1Ti
1041E0-5S	1,650 (2,240)	2,500 (3,390)	End Grip O-T	#5 Spline	Button	11-1/4 (285.7)	19 (8.6)	1/2 NPT 3/4 (19)	IR3940A1Ti
1042PT-TH	1,900 (2,576)	3,200 (4,338)	Pistol Grip	1" Sq.	Through Hole	9-13/16 (250.9)	24.6 (11.1)	1/2 NPT 3/4 (19)	IR3942P2Ti
1042PT-5S	1,900 (2,576)	3,200 (4,338)	Pistol Grip	#5 Spline	Button	9-13/16 (250.9)	24.6 (11.1)	1/2 NPT 3/4 (19)	IR3942P1Ti
1042EI-TH	1,900 (2,576)	3,200 (4,338)	End Grip I-T	1" Sq.	Through Hole	12-7/16 (314.9)	24.2 (10.9)	1/2 NPT 3/4 (19)	IR3942B2Ti
1042E0-TH	1,900 (2,576)	3,200 (4,338)	End Grip O-T	1" Sq.	Through Hole	12-7/16 (314.9)	24.2 (10.9)	1/2 NPT 3/4 (19)	IR3942A2Ti
1042EI-5S	1,900 (2,576)	3,200 (4,338)	End Grip I-T	#5 Spline	Button	12-7/16 (314.9)	24.2 (10.9)	1/2 NPT 3/4 (19)	IR3942B1Ti
1042E0-5S	1,900 (2,576)	3,200 (4,338)	End Grip O-T	#5 Spline	Button	12-7/16 (314.9)	24.2 (10.9)	1/2 NPT 3/4 (19)	IR3942A1Ti

All models available with extended anvil. Contact ATP Customer Service for more information.
See Ozat Sockets starting on page 36. Socket retaining accessories are provided for all sockets in the Ozat section.

Super Duty 1-1/2" Drive Class Impact Tools

Available with #5 Spline Drive



1550 & 1552 High Output Series

- High output twin hammer mechanisms
- Bronze end plates for increased motor durability
- Model 1552 high output 7 vane motor
- Steel hammer case
- Integral muffler for noise reduction
- Three piece housing for ease of repair

1520 Series

- Two jaw clutch transfers high power
- Steel clutch housing
- Great for hard and soft draw applications
- Integral muffler for noise reduction
- Three piece housing for ease of repair



1-3/8" - 1-1/2" Bolt Capacity (35mm - 38mm)

Models	Working Torque ft lb (Nm)	Max Torque ft lb (Nm)	Handle Type	Drive Size	Socket Retainer	Length in (mm)	Weight lb (kg)	Air Inlet / Hose ID in (mm)	Comparable To
1550EI-TH	2,500 (3,400)	3,000 (4,067)	End Grip I-T	1-1/2" Sq.	Through Hole	14-1/2 (368.3)	33 (14.9)	1/2 NPT 3/4 (19)	IR2950B7
1550EO-TH	2,500 (3,400)	3,000 (4,067)	End Grip O-T	1-1/2" Sq.	Through Hole	14-1/2 (368.3)	33 (14.9)	1/2 NPT 3/4 (19)	IR2950A7
1550EI-5S	2,500 (3,400)	3,000 (4,067)	End Grip I-T	#5 Spline	Button	14-1/2 (368.3)	33 (14.9)	1/2 NPT 3/4 (19)	IR2950B1
1550EO-5S	2,500 (3,400)	3,000 (4,067)	End Grip O-T	#5 Spline	Button	14-1/2 (368.3)	33 (14.9)	1/2 NPT 3/4 (19)	IR2950A1
1552EO-TH	3,300 (4,474)	4,000 (5,424)	End Grip O-T	1-1/2" Sq.	Through Hole	14-1/2 (368.3)	33 (14.9)	1/2 NPT 3/4 (19)	IR3955A2Ti
1552EI-5S	3,300 (4,474)	4,000 (5,424)	End Grip I-T	#5 Spline	Button	14-1/2 (368.3)	33 (14.9)	1/2 NPT 3/4 (19)	IR3955B1Ti
1552EI-TH	3,300 (4,474)	4,000 (5,424)	End Grip I-T	1-1/2" Sq.	Through Hole	14-1/2 (368.3)	33 (14.9)	1/2 NPT 3/4 (19)	IR3955B2Ti
1520EI-TH	2,500 (3,400)	3,000 (4,067)	End Grip I-T	1-1/2" Sq.	Through Hole	14-11/16 (373.3)	33.7 (15.2)	1/2 NPT 3/4 (19)	CP6120-PASED
1520EI-5S	2,500 (3,400)	3,000 (4,067)	End Grip I-T	#5 Spline	Button	14-11/16 (373.3)	33.7 (15.2)	1/2 NPT 3/4 (19)	CP6120-PASEL
1520EO-5S	2,500 (3,400)	3,000 (4,067)	End Grip I-T	#5 Spline	Button	14-11/16 (373.3)	33.7 (15.2)	1/2 NPT 3/4 (19)	CP6120-PASEL

All models available with extended anvil. Contact ATP Customer Service for more information.
See Ozat Sockets starting on page 36. Socket retaining accessories are provided for all sockets in the Ozat section.

Super Duty “Heavy Hitters” Impact Tools

Available in 1-1/2”, 2-1/2” and 3-1/2” Drive Sizes



1580LT-TH

1578 & 1580 Series

- Precision ball and cam mechanism
- Built-in lubricator
- Vertical and horizontal hangers
- Assist handle



2588LT-TH

2582 & 2588 Series

- Precision ball and cam mechanism
- Built-in lubricator
- Vertical and horizontal hangers
- Assist handle



3599LT-TH

3599 Series

“The Worlds Most Powerful Impact Tool”

- Precision ball and cam mechanism
- Built-in lubricator
- Vertical and horizontal hangers
- Assist handle

1-1/2” - 4” Bolt Capacity (38mm - 102mm)

Models	Working Torque ft lb (Nm)	Max Torque ft lb (Nm)	Handle Type	Drive Size	Socket Retainer	Length in (mm)	Weight lb (kg)	Air Inlet / Hose ID in (mm)	Comparable To
1578LT-TH	5,500 (7,456)	10,000 (13,560)	T-Handle Lever	1-1/2” Sq.	Through Hole	23 (584.2)	86 (39)	3/4 NPT 1 (25)	IR578A1
1580LT-TH	5,900 (8,000)	13,560 (18,383)	T-Handle Lever	1-1/2” Sq.	Through Hole	23 (584.2)	88 (39.9)	3/4 NPT 1 (25)	IR5980A1
2582LT-TH	10,000 (13,560)	20,000 (27,114)	T-Handle Lever	2-1/2” Sq.	Through Hole	25-7/16 (645)	120 (54.4)	3/4 NPT 1 (25)	IR5982A1
2588LT-TH	25,000 (33,892)	50,000 (67,784)	T-Handle Lever	2-1/2” Sq.	Through Hole	26-5/8 (675.6)	215 (97.5)	1 NPT 1 (25)	IR588A1
3599LT-TH	42,000 (57,000)	80,000 (108,500)	T-Handle Lever	3-1/2” Sq.	Through Hole	37-1/2 (952.5)	599 (271.7)	1-1/4 NPT 1-1/2 (38)	IR599A1

See Ozat Sockets starting on page 36. Socket retaining accessories are provided for all sockets in the Ozat section.

See Retaining Rings and Pins for 2-1/2” on page 73, and 3-1/2” drives on page 75.

ATP Die Grinders

.5 and 1 HP Tools

ATP collet and threaded arbor straight grinders are a complete range of tools in three horsepower offerings, to help you get the job done in the most demanding applications and environments.

These tools excel in metal finishing applications powering mounted burrs and type 1 grinding wheels.



DG122S-1/4



DG122S-1/4-E



4420

Straight Grinder Specifications

Models	Rated HP (kW)	Free Speed RPM	Throttle Lever Type	Spindle Output	Wheel Diameter in (mm)	Wheel Type Maximum Thickness	Overall Length in (mm)	Net Weight lb (kg)	Air Inlet / Hose ID in (mm)	Exhaust
4420	.5 (.37)	23,000	Lever	1/4" Collet	*N/R	Mounted Burrs	6-13/16 (173)	1.7 (.76)	1/4 NPT 3/8 (10)	Front
DG122S-1/4	1 (.75)	22,000	Lever	1/4" Collet	*N/R	Mounted Burrs	6-1/2 (166)	2.6 (1.2)	1/4 NPT 3/8 (10)	Front
DG122S-1/4-E	1 (.75)	22,000	Lever	1/4" Collet	*N/R	Mounted Burrs	12-9/32 (315)	3.6 (1.6)	1/4 NPT 3/8 (10)	Front

*N/R: Not Required

ATP Horizontal Grinders



1.2 HP 1200 Series

ATP 1200 series horizontal grinders have set the standard for high performance rugged production grinders used in fabrication shops, fabricated metal plants, petrochemical maintenance, shipyards, foundries, and many other markets.

The extensive product range offers speeds and spindle configurations to improve operator productivity.



1215S-C



1215S-R4



1215S-1/4

Horizontal Grinder Specifications

Models	Rated HP (kW)	Free Speed RPM	Throttle Lever Type	Spindle Output	Wheel Guard Dia. in (mm)	Wheel Type Maximum Thickness	Overall Length in (mm)	Net Weight lb (kg)	Air Inlet Hose ID in (mm)	Exhaust
1215S-1/4	1.2 (.9)	15,000	Lever	1/4" Collet	*N/R	Mounted Burrs	17-1/2 (444)	5.5 (2.5)	3/8 NPT 3/8 (10)	Side
1215S-3/8	1.2 (.9)	15,000	Lever	3/8" Collet	*N/R	Mounted Burrs	17-1/2 (444)	5.5 (2.5)	3/8 NPT 3/8 (10)	Side
1215S-C	1.2 (.9)	15,000	Lever	3/8"-24	Cone	Cone Wheels	16-1/8 (410)	5.3 (2.4)	3/8 NPT 3/8 (10)	Side
1215S-R3	1.2 (.9)	15,000	Lever	3/8"-24	3" (76)	1 (1/2")	16-3/4 (425)	5.9 (2.7)	3/8 NPT 3/8 (10)	Side
1215S-R4	1.2 (.9)	15,000	Lever	3/8"-24	4" (101)	1 (1/4")	16-3/4 (425)	6 (2.7)	3/8 NPT 3/8 (10)	Side
1218S-1/4	1.2 (.9)	18,000	Lever	1/4" Collet	*N/R	Mounted Burrs	17-1/2 (444)	5.5 (2.5)	3/8 NPT 3/8 (10))	Side
1218S-3/8	1.2 (.9)	18,000	Lever	3/8" Collet	*N/R	Mounted Burrs	17-1/2 (444)	5.5 (2.5)	3/8 NPT 3/8 (10)	Side
1218S-C	1.2 (.9)	18,000	Lever	3/8"-24	Cone	Cone Wheels	16-1/8 (410)	5.3 (2.4)	3/8 NPT 3/8 (10)	Side
1218S-R3	1.2 (.9)	18,000	Lever	3/8"-24	3" (76)	1 (1/2")	16-3/4 (425)	5.9 (2.7)	3/8 NPT 3/8 (10)	Side

Standard equipment on all models: standard guard size per wheel diameter (guard not required with collet tools)

All 1200 series tools have governed motors.

*N/R: Not Required

Other Model Options Available: Build your desired model

Series	Free Speed RPM	Side Exhaust	Spindle Output
12	09 = 9,000	S	1/4 = 1/4" Collet
12	12 = 12,000	S	3/8 = 3/8" Collet
12	15 = 15,000	S	C = Cone Wheel
12	18 = 18,000	S	R3 = 3" Type 1 Guard
			R4 = 4" Type 1 Guard

Model Example: 1209S-3/8 = 12 series, 9000 rpm, side exhaust, 3/8" collet

ATP Heavy Duty Extended Horizontal Grinders

1.2 HP E1200HD Series



ATP E1200HD series heavy duty extended horizontal grinders have set the standard for high performance rugged production grinders used in finishing castings in foundries and other unique applications. **The heavy duty double row spindle bearing and dust cover provide robust durability in the most demanding metal finishing applications.**

The extensive product range offers heavy duty extensions of 7", 13", 26", and 36" in speeds and spindle configurations to allow the operator to work in confined longer reach applications.



E1215S-13HD-1/4



Heavy Duty Double Row Spindle Bearing and Cover on all HD Models



E1212S-26HD-1/4

Extended Grinder Specifications

Models	Rated HP (kW)	Free Speed RPM	Throttle Type	Spindle Output	Overall Length in (mm)	Extension Length in (mm)	Net Weight lb (kg)	Extension Diameter in	Air Inlet / Hose ID in (mm)	Exhaust
E1218S-7HD-1/4	1.2 (.9)	18,000	Lever	1/4" Collet	20-1/2 (520)	7 (178)	5.6 (2.5)	1-3/8	3/8 NPT 3/8 (10)	Side
E1218S-7HD-C	1.2 (.9)	18,000	Lever	3/8"-24	19 (483)	7 (178)	5.4 (2.4)	1-3/8	3/8 NPT 3/8 (10)	Side
E1215S-13HD-1/4	1.2 (.9)	15,000	Lever	1/4" Collet	26-1/2 (673)	13 (330)	7.2 (3.3)	1-3/8	3/8 NPT 3/8 (10)	Side
E1215S-13HD-3/8	1.2 (.9)	15,000	Lever	3/8" Collet	26-1/2 (673)	13 (330)	7.2 (3.3)	1-3/8	3/8 NPT 3/8 (10)	Side
E1212S-26HD-1/4	1.2 (.9)	12,000	Lever	1/4" Collet	40 (1,016)	26 (660)	9.4 (4.3)	1-3/8	3/8 NPT 3/8 (10)	Side
E1212S-26HD-C	1.2 (.9)	12,000	Lever	3/8"-24	38-1/2 (978)	26 (660)	9.2 (4.2)	1-3/8	3/8 NPT 3/8 (10)	Side
E1212S-36HD-3/8	1.2 (.9)	12,000	Lever	3/8" Collet	50 (1,270)	36 (914)	11.3 (5.1)	1-3/8	3/8 NPT 3/8 (10)	Side
E1212S-36HD-C	1.2 (.9)	12,000	Lever	3/8"-24	48-1/2 (1,232)	36 (914)	11.1 (5.0)	1-3/8	3/8 NPT 3/8 (10)	Side

All E1200 series tools have governed motors.

Other Model Options Available: Build your desired model

Series	Free Speed RPM	Side Exhaust	Extension Length	Spindle Output
E12	09 = 9,000	S	7HD = 7"	1/4 = 1/4" Collet
E12	12 = 12,000	S	13HD = 13"	3/8 = 3/8" Collet
E12	15 = 15,000	S	26HD = 26"	C = Cone Wheel
E12	18 = 18,000	S	36HD = 36"	

Model Example: E1209S-13HD-C = E12 series, 9,000 rpm, side exhaust, 13" heavy bearing extended housing, cone wheel

Non standard lengths available upon request

ATP Extended Horizontal Grinders



1.2 HP E1200 Series

ATP E1200 series extended horizontal grinders have set the standard for high performance rugged production grinders used in finishing castings in foundries and other unique finishing applications.

The extensive product range offers extensions of 7", 13", 26", and 36" in speeds and spindle configurations to allow the operator to work in confined longer reach applications.



E1212S-26-1/4



E1218S-7-C

Extended Grinder Specifications

Models	Rated HP (kW)	Free Speed RPM	Throttle Type	Spindle Output	Overall Length in (mm)	Extension Length in (mm)	Net Weight lb (kg)	Extension Diameter in	Air Inlet / Hose ID in (mm)	Exhaust
E1218S-7-1/4	1.2 (.9)	18,000	Lever	1/4" Collet	20-1/2 (520)	7 (178)	5.6 (2.5)	1	3/8 NPT 3/8 (10)	Side
E1218S-7-C	1.2 (.9)	18,000	Lever	3/8"-24	19 (483)	7 (178)	5.4 (2.4)	1	3/8 NPT 3/8 (10)	Side
E1215S-13-1/4	1.2 (.9)	15,000	Lever	1/4" Collet	26-1/2 (673)	13 (330)	7.2 (3.3)	1	3/8 NPT 3/8 (10)	Side
E1215S-13-3/8	1.2 (.9)	15,000	Lever	3/8" Collet	26-1/2 (673)	13 (330)	7.2 (3.3)	1	3/8 NPT 3/8 (10)	Side
E1212S-26-1/4	1.2 (.9)	12,000	Lever	1/4" Collet	40 (1,016)	26 (660)	9.4 (4.3)	1	3/8 NPT 3/8 (10)	Side
E1212S-26-C	1.2 (.9)	12,000	Lever	3/8"-24	38-1/2 (978)	26 (660)	9.2 (4.2)	1	3/8 NPT 3/8 (10)	Side
E1212S-36-3/8	1.2 (.9)	12,000	Lever	3/8" Collet	50 (1,270)	36 (914)	11.3 (5.1)	1	3/8 NPT 3/8 (10)	Side
E1212S-36-C	1.2 (.9)	12,000	Lever	3/8"-24	48-1/2 (1,232)	36 (914)	11.1 (5.0)	1	3/8 NPT 3/8 (10)	Side

All E1200 series tools have governed motors.

Other Model Options Available: Build your desired model

Series	Free Speed RPM	Side Exhaust	Extension Length	Spindle Output
E12	09 = 9,000	S	7 = 7"	1/4 = 1/4" Collet
E12	12 = 12,000	S	13 = 13"	3/8 = 3/8" Collet
E12	15 = 15,000	S	26 = 26"	C = Cone Wheel
E12	18 = 18,000	S	36 = 36"	

Model Example: E1209S-13-C = E12 series, 9,000 rpm, side exhaust, 13" standard bearing extended housing, cone wheel

Non standard lengths available upon request

ATP Vertical Grinders

3 HP 356 Series



ATP 3 HP vertical grinders continue to stand the test of time as high performance durable tools used in the most demanding heavy metal removal and finishing applications.

Features

- Safety lock-off lever throttle
- Stainless steel corrosion resistant governors
- Rugged sand cast housings are highly durable in extreme environments
- Ease of service design
- “Techalloy” housing provides the ultimate in reduced weight and strength



356VSL-60-6



356VSL-60-7

Vertical Grinder Specifications

Models	Rated HP (kW)	Free Speed rpm	Wheel Type	Wheel Diameter in (mm)	Weight Less Guard lb (kg)	Height to Flange Bottom in (mm)	Side to Center in (mm)	Spindle Thread in	Air Inlet / Hose ID in (mm)
356VSL-45-7	3 (2.2)	4,500	27 & 28	7 (178)	7.2 (3.2)	5-1/2 (145)	1-11/16 (43)	5/8-11	1/2 NPT 1/2 (13)
356VSL-60-6	3 (2.2)	6,000	6" Cup	6 (152)	7.2 (3.2)	5-1/2 (145)	1-11/16 (43)	5/8-11	1/2 NPT 1/2 (13)
356VSL-60-7	3 (2.2)	6,000	27 & 28	7 (178)	7.2 (3.2)	5-1/2 (145)	1-11/16 (43)	5/8-11	1/2 NPT 1/2 (13)
356VSL-60-9	3 (2.2)	6,000	27 & 28	9 (229)	7.2 (3.2)	5-1/2 (145)	1-11/16 (43)	5/8-11	1/2 NPT 1/2 (13)
356VSL-80-7	3 (2.2)	8,000	27 & 28	7 (178)	7.2 (3.2)	5-1/2 (145)	1-11/16 (43)	5/8-11	1/2 NPT 1/2 (13)

Standard equipment on all models: standard guard size per wheel diameter, 2" wheel flange and spindle nut, spindle wrench 1100-200 (2") and 1102-015 (5/32") allen type wrench

Equipment at extra price: spindle / wheel retention screw and retention screw collar 650-60, optional wheel guards

ATP Vertical Grinders

4 HP 466 Series



ATP 4 HP vertical grinders continue to stand the test of time as high performance durable tools used in the most demanding heavy metal removal and finishing applications.

Features

- Safety lock-off lever throttle
- Stainless steel corrosion resistant governors
- Rugged sand cast housings are highly durable in extreme environments
- Ease of service design
- "Techalloy" housing provides the ultimate in reduced weight and strength



466VSL-60-9



466VSL-60-6

Vertical Grinder Specifications

Models	Rated hp (kW)	Free Speed rpm	Wheel Type	Wheel Diameter in (mm)	Weight Less Guard lb (kg)	Height to Flange Bottom in (mm)	Side to Center in (mm)	Spindle Thread in	Air Inlet / Hose ID in (mm)
466VSL-45-7	4 (3)	4,500	27 & 28	7 (178)	9.5 (4.3)	6-7/16 (174)	1-7/8 (48)	5/8-11	1/2 NPT 1/2 (13)
466VSL-60-6	4 (3)	6,000	6" Cup	6 (152)	9.5 (4.3)	6-7/16 (174)	1-7/8 (48)	5/8-11	1/2 NPT 1/2 (13)
466VSL-60-7	4 (3)	6,000	27 & 28	7 (178)	9.5 (4.3)	6-7/16 (174)	1-7/8 (48)	5/8-11	1/2 NPT 1/2 (13)
466VSL-60-9	4 (3)	6,000	27 & 28	9 (229)	9.5 (4.3)	6-7/16 (174)	1-7/8 (48)	5/8-11	1/2 NPT 1/2 (13)
466VSL-80-7	4 (3)	8,000	27 & 28	7 (178)	9.5 (4.3)	6-7/16 (174)	1-7/8 (48)	5/8-11	1/2 NPT 1/2 (13)

Standard equipment on all models: standard guard size per wheel diameter, 2" wheel flange and spindle nut, spindle wrench 1100-200 (2") and 1102-015 (5/32") allen type wrench

Equipment at extra price: spindle /wheel retention screw and retention screw collar 650-60, optional wheel guards

ATP Horizontal Grinders

3 and 4 HP ATP 356 and 465 Series



ATP horizontal series of grinders continue to stand the test of time as high performance durable tools used in the most demanding heavy metal removal and finishing applications.

Features

- Safety lock-off lever throttle
- Stainless steel corrosion resistant governors
- Rugged sand cast housings are highly durable in extreme environments
- Ease of service design
- “Techalloy” housing provides the ultimate in reduced weight and strength.



465HG-60-6



356HSL-60-6

Horizontal Grinder Specifications

Models	Handle Type	Rated hp (kW)	Free Speed RPM	Wheel Guard Size	Wheel Type and Size	Weight Less Guard lb (kg)	Length to Flange in (mm)	Side to Center in (mm)	Spindle Thread in	Air Inlet / Hose ID in (mm)
356HSL-45-8	Lever	3 (2.2)	4,500	8"	1 - 8" x 1"	10.5 (4.8)	20-1/8 (524)	1-1/4 (32)	5/8-11	1/2 NPT 1/2 (13)
356HSL-60-6	Lever	3 (2.2)	6,000	6"	1 - 6" x 1"	10.5 (4.8)	20-1/8 (524)	1-1/4 (32)	5/8-11	1/2 NPT 1/2 (13)
356HG-45-8	Grip	3 (2.2)	4,500	8"	1 - 8" x 1"	10.5 (4.8)	20-1/8 (524)	1-1/4 (32)	5/8-11	1/2 NPT 1/2 (13)
356HG-60-6	Grip	3 (2.2)	6,000	6"	1 - 6" x 1"	10.5 (4.8)	20-1/8 (524)	1-1/4 (32)	5/8-11	1/2 NPT 1/2 (13)
465HSL-45-8	Lever	4 (3.3)	4,500	8"	1 - 8" x 1"	10.5 (4.8)	20-7/8 (530)	1-1/4 (32)	5/8-11	1/2 NPT 1/2 (13)
465HSL-60-6	Lever	4 (3.3)	6,000	6"	1 - 6" x 1"	12.5 (5.7)	20-7/8 (530)	1-1/4 (32)	5/8-11	1/2 NPT 1/2 (13)
465HG-45-8	Grip	4 (3.3)	4,500	8"	1 - 8" x 1"	12.5 (5.7)	20-7/8 (530)	1-1/4 (32)	5/8-11	1/2 NPT 1/2 (13)
465HG-60-6	Grip	4 (3.3)	6,000	6"	1 - 6" x 1"	12.5 (5.7)	20-7/8 (530)	1-1/4 (32)	5/8-11	1/2 NPT 1/2 (13)

Standard equipment on all models: standard guard size per wheel diameter (guard not required with cone wheels), 2" wheel flange and spindle nut, spindle wrench 1100-200 (2") and 1102-015 (5/32") allen type wrench.

Equipment at extra price: spindle /wheel retention screw and retention screw collar 650-60, optional wheel guards.

ATP Rammers



ATP rammers are ideally suited for foundry and refractory applications.

Features

T2BA:

- Adjustable packing nut to reduce air blow-by for maximum power.
- Aluminum backhead to reduce weight.

T241F:

- Self cleaning rocker valve for increased performance.
- Adjustable packing nut to reduce air blow by for maximum power.
- Muffler to reduce noise to the operator.

T241F-3-1/4R



T2BA



Rammer Specifications

Models	Bore x Stroke in (mm) x in (mm)	BPM	Length in (mm)	Weight lb (kg)	Butt Diameter in (mm)	Air Inlet / Hose ID in (mm)
T2BA	1 (25) x 2-1/2 (63)	1,725	15-3/4 (400)	7.7 (3.5)	2-1/2 (64)	1/4 NPT 3/8 (10)
T241F-3-1/4R	1-5/16 (33) x 4 (102)	1,590	52-3/4 (1,370)	28.9 (13.1)	3-1/4 (76)	1/2 NPT 1/2 (13)

Standard Butts: Rubber

T2BA Optional Butts:

- 1-3/4" Rubber
- 2-1/2" Steel
- 5" Rubber
- Other butt sizes available upon request

T241F Optional Butts:

- 3" Rubber
- 3" Malleable
- 3" Aluminum
- 5" Rubber
- Other butt sizes available upon request

ATP Scaler Tools

ATP needle and chisel scalers are offered in a compact design for close quarter work removing weld flux, paint, scale, weld spatter, rust and other residue from a variety of irregular surfaces in fabrication shops, shipyards foundries, refineries, construction sites and MRO applications.

Features

- Rugged design and precision manufacturing specifications make these scalers last longer with low maintenance costs.
- Model A-1ALT scaler quickly converts to a needle scaler for better tool utilization.



**A-1 ALT
Weld Flux Scaler**



**A-1 ALTNS
Needle Scaler**

Scaler Specifications

Models	Scaler Model Type	Throttle Type	Bore x Stroke in (mm) x in (mm)	BPM	Weight lb (kg)	Length in (mm)	Air Inlet / Hose ID in (mm)
A-1ALT	Weld Flux Scaler	Lever	1 (25.4) x 1-1/8 (28.8)	4,600	4.5 (2.17)	9-1/2 (243)	1/4 NPT 3/8 (10)
A-1ALTNS	Needle Scaler	Lever	1 (25.4) x 1-1/8 (28.8)	4,600	6 (2.7)	17-1/2 (448)	3/8 NPT 3/8 (10)

ATP Chipping Hammers

ATP's Heavy Duty Chipping Hammers

Favored by contractors and industrial users alike, ATP Chippers set new standards for pneumatic tools. Their crisp, smooth valve operation produces extra hard hitting power, while the heat treated alloy steel cylinder and piston provide long life.

Additionally, ATP Chippers are ergonomically advanced in design, the closed grip handle locates the operator's hand and arm in-line with the chisel for maximum effectiveness and operator comfort. This makes the ATP Chippers much easier to handle and less fatiguing when used over long periods of time.

If you need a **RUGGED, RELIABLE PERFORMER** on your job site, you can't do better than the **ATP ERGONOMIC CHIPPING HAMMER**.

Features

- Heavy duty steel handles
- Available in the popular 2"-3"-4" stroke versions
- Available with either hex or round chisel bushing

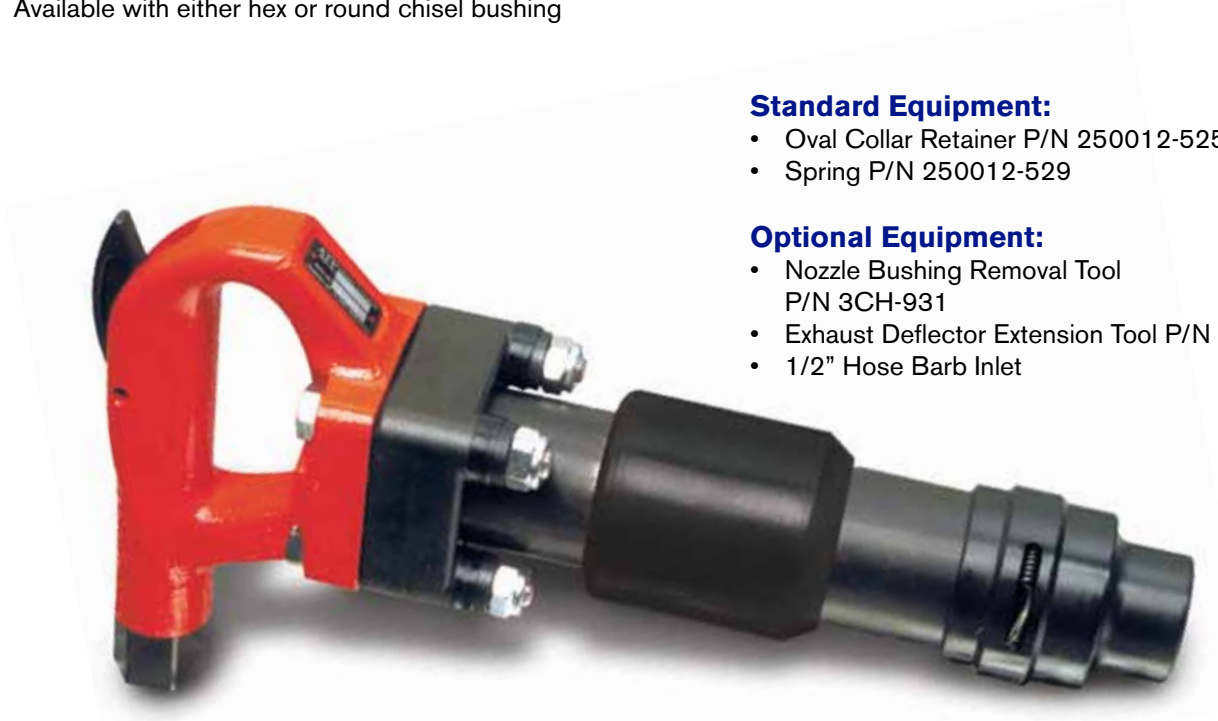

Standard Equipment:

- Oval Collar Retainer P/N 250012-525
- Spring P/N 250012-529

Optional Equipment:

- Nozzle Bushing Removal Tool P/N 3CH-931
- Exhaust Deflector Extension Tool P/N 3CH-932
- 1/2" Hose Barb Inlet

Chipping Hammer Specifications

Models	Weight lb (kg)	Overall Length in (mm)	BPM	Bore x Stroke in	Chisel Bushing	CFM	Air Inlet / Hose ID in (mm)
2HB	17.2 (7.8)	14 (365)	2,200	1-1/8 x 3.03	.580 Hex	34 cfm	3/8 NPT 1/2 (13)
2RB	17.2 (7.8)	14 (365)	2,200	1-1/8 x 3.03	.680 Round	34 cfm	3/8 NPT 1/2 (13)
3HB	18.5 (8.4)	15-1/4 (400)	1,900	1-1/8 x 3.70	.580 Hex	33 cfm	3/8 NPT 1/2 (13)
3RB	18.5 (8.4)	15-1/4 (400)	1,900	1-1/8 x 3.70	.680 Round	33 cfm	3/8 NPT 1/2 (13)
4HB	19.5 (8.8)	16-1/2 (425)	1,500	1-1/8 x 4.02	.580 Hex	30 cfm	3/8 NPT 1/2 (13)
4RB	19.5 (8.8)	16-1/2 (425)	1,500	1-1/8 x 4.02	.680 Round	30 cfm	3/8 NPT 1/2 (13)

Thor Breakers



® **Legendary Construction
Air Tools Since 1886**

Thor Breakers

Thor Breakers, available in the 30, 60 and 90 lb Class, are “Tools as Tough as their name”. The 30 lb class Thor 17 Breakers are light weight rugged tools designed for light to medium construction and plant maintenance work such as demolition of floors, pavement, masonry walls, black top and frozen dirt. The 17 is also an excellent choice for bridge deck demolition work.

The 60 lb class Thor 234 and the 90 lb class Thor 125 breakers are designed to deliver the performance and endurance necessary for a variety of heavy duty construction and plant maintenance applications, such as breaking rock, concrete, reinforced concrete, frozen earth and pavement.

Features of all Thor Breakers:

- Alloy steel forgings
- Precision American machined parts for long life
- Rugged 4 bolt design for extra duty service
- Continuous lubrication provided by internal oilers for long service life
- Air inlet swivel for maneuverability



**17
(30lb Class)**



**234-1.125
(60lb Class)**



**125-1.125
(90lb Class)**

Paving Breaker Specifications

Models	Chuck Size in	Bore x Stroke in (mm) x in (mm)	BPM	Length in (mm)	Weight lb (kg)	CFM	Air Inlet
17	7/8 x 3-1/4	1-3/4 (44) x 3-3/8 (86)	1,550	22-1/2 (572)	32 (14.5)	46	3/8 NPT, male
17-1	1 x 4-1/4	1-3/4 (44) x 3-3/8 (86)	1,550	22-1/2 (572)	32 (14.5)	46	3/8 NPT, male
234-1.125	1-1/8 x 6	2-1/4 (57) x 4-3/32 (104)	1,400	25-5/8 (651)	67 (30)	60	3/8 NPT, male
234-1.25	1-1/4 x 6	2-1/4 (57) x 4-3/32 (104)	1,400	25-5/8 (651)	67 (30)	60	3/8 NPT, male
125-1.125	1-1/8 x 6	2-5/8 (66.67) x 6-1/16 (154)	1,250	28-3/4 (730)	92 (42)	80	3/8 NPT, male
125-1.25	1-1/4 x 6	2-5/8 (66.67) x 6-1/16 (154)	1,250	28-3/4 (730)	92 (42)	80	3/8 NPT, male

Thor Clay Diggers



® **Legendary Construction**
Air Tools Since 1886

Thor 18 “Digger”

Thor 18 CD is a dropped forged clay digger recommended for digging clay in packed soil from around footings, forms and other construction areas. It's 29 lb weight makes it a hard hitting tool, making quick work of the task at hand.

Features

- Alloy steel forgings
- Heat treated alloy steel components
- Slim design for work in tight areas
- Latch retainer for positive retention and quick change of accessories
- Swivel air inlet for operator comfort
- Closed grip handle with lever throttle



18CD-.875

Clay Digger Specifications

Models	Chuck Size in	Bore in (mm)	BPM	Length in (mm)	Weight lb (kg)	CFM	Air Inlet
18CD-.875	7/8 Hex x 3-1/4	1-3/4 (44.8)	1,500	22-3/4 (583)	29 (13)	38	3/8 NPT, male
18CD-1	1 Hex x 4-1/4	1-3/4 (44.8)	1,500	22-3/4 (583)	29 (13)	38	3/8 NPT, male

Thor Rivet Busters

8" and 11" Stroke Models



Thor RB-08 and RB-11 demolition tools are ideal for medium to heavy concrete demolition on bridge decks, parking garage columns, bridge pillars, and rivet and bolt cutting applications.

Features

- Closed grip with inside trigger provides operator comfort and trigger protection
- Hardened steel piston and cylinder for excellent wear and life
- Uses industry standard 11x Jumbo steel
- Tease throttle for exceptional start and control
- Internal piston safety retainer



RB-11

Rivet Buster Specifications

Models	Bore x Stroke in (mm) x in (mm)	BPM	Length in (mm)	Weight lb (kg)	Chisel Shank	CFM	Air Inlet / Hose ID in (mm)
RB-08	1-3/16 (30) x 8 (203)	980	22-1/2 (572)	30 (13.61)	Jumbo	44	1/2 NPT 1/2 (13)
RB-11	1-3/16 (30) x 11 (279)	850	25-1/2 (648)	33 (15)	Jumbo	50	1/2 NPT 1/2 (13)

Thor Back Fill Tamper

Thor's 6T Backfill Tamper is a 40 lb Class Tamper that has also "Stood the Test of Time". It's powerful 800 Blows Per Minute (BPM) is easily guided by one person due to its smooth operation and superb balance. The 6T is designed to effectively compact soil around foundations and other structures and for compacting backfill in trenches and other construction holes requiring compaction.

Features

- High power to weight operation
- Powerful blows quickly compacts clay, gravel and other backfill materials
- Heat treated cylinder and piston for long service life
- Hex head bolt clamp for easy tamper butt changes
- Lever throttle operation

Backfill Tamper Specifications

Model	Taper	Bore x Stroke in (mm) x in (mm)	BPM	Length in (mm)	Weight lb (kg)	CFM	Air Inlet
6T	804 Taper	1-1/2 (38) x 5-1/2 (140)	800	48-1/4 (1,226)	40 (18)	38	1/2 NPT

6T



ATP Air Centrifugal Sump Pump



551P

ATP 551P Sump Pump

The 551P is a light weight, portable, air operated, fully submersible sump pump with the power to pump up to 216 gallons of water per minute.

This non-clogging, self-cleaning pump for clean or dirty water, sewage, oil and sludge is capable of handling all your pumping requirements. The rugged cast iron housing is built to take life's hard knocks. The built in oiler will handle up to 16 hours of continuous air motor lubrication.

Convenient carry handles make this versatile pump easy to handle at the job site. The adjustable governor prevents "run-away" when sump is pumped dry or if the impeller clears water while it is in operation.

Features

- Submersible
- Portable
- Cast iron housing construction
- Steel impeller
- Built in oiler

Maximum Performance:

- Max Flow - 216 GPM
- Max Head - 92 Feet

Standard Equipment:

- Built in oiler
- Extended exhaust pipe with check valve to prevent water from entering the motor through the exhaust

Optional Equipment:

- Air valve, lever type for remote operation. (at additional cost)

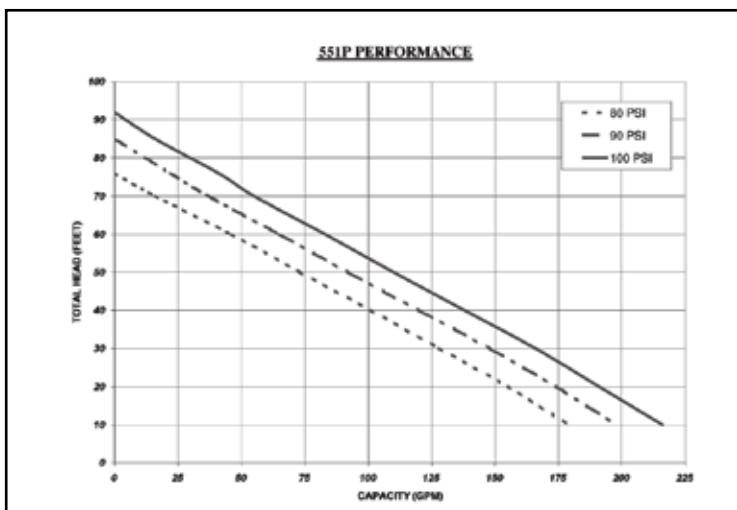

Pump Specifications

Model	Height in (mm)	Weight lb (Kg)	Opening Pump Will Enter	Discharge Opening in	Pump Housing Material	CFM	Air Inlet
551P	20 (513)	41 (18.6)	8-5/8" x 10-1/2"	2-1/2 NPT	Cast Iron	75	1/2 NPT

*interchanges with Thor 51T

ATP Air Chain Hoists

500 to 4000 lb. Capacity



Features

- Self-locking worm gear design eliminates the need for a break (including break repairs and brake adjustments). When air flow to the motor stops, the worm gear stops and holds the load securely
- Heat-treated alloy steel chain provides strength and flexibility
- Powerful air motor provides positive high-torque starting characteristics
- All rotating parts supported on anti-friction bearings for smooth operation
- Housing of sectioned aluminum "Techalloy" castings provide extra strength and durability
- Automatic, adjustable limit stops - prevent over-travel, even at high speeds
- Withstands frequent stopping, starting and stalling - without damage or overheating
- Operator controlled speed - for precise load spotting
- Remote pendent control - available in all sizes
- Top hook swivels 360°
- Standard safety cable attachment point provides secure installation

Applications:

The 91200 extra heavy duty hoist series is designed to lift raw or processed materials in steel manufacturing plants, heavy assemblies in automobile, truck and tractor factories, aircraft, aerospace industries, heavy machinery manufacture, petrochemical plants and food processing operations.

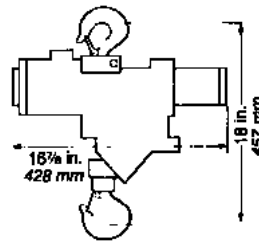

91200 (500-2000 lb.)

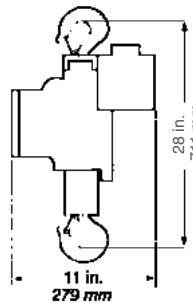

91200 (4000 lb.)



91200

Air Hoist Specifications

Models	Control Description	Rated Capacity lb (kg)	Lifting Hook Speed at Rated Capacity ft./min (m/min)	Standard Lift Length ft (m)	Standard Control Length ft (m)	Net Weight lb (kg)	Air Inlet / Hose ID in (mm)
91200-DC	Pull Chain	500 (227)	44 (13.4)	15 (4.6)	10 (3.1)	60 (27.3)	1/2 NPT 3/4 (19)
91200-DP	Pendent	500 (227)	44 (13.4)	15 (4.6)	10 (3.1)	63 (28.6)	1/2 NPT 3/4 (19)
91200-MC	Pull Chain	1,000 (454)	20 (6.1)	15 (4.6)	10 (3.1)	60 (27.3)	1/2 NPT 3/4 (19)
91200-MP	Pendent	1,000 (454)	20 (6.1)	15 (4.6)	10 (3.1)	63 (28.6)	1/2 NPT 3/4 (19)
91200-2MC	Pull Chain	2,000 (907)	12 (3.7)	15 (4.6)	10 (3.1)	60 (27.3)	1/2 NPT 3/4 (19)
91200-2MP	Pendent	2,000 (907)	12 (3.7)	15 (4.6)	10 (3.1)	63 (28.6)	1/2 NPT 3/4 (19)
91200-4MC	Pull Chain	4,000 (1,814)	5 (1.5)	15 (4.6)	10 (3.1)	109 (49.4)	1/2 NPT 3/4 (19)
91200-4MP	Pendent	4,000 (1,814)	5 (1.5)	15 (4.6)	10 (3.1)	112 (50.8)	1/2 NPT 3/4 (19)

Standard Equipment: swivel top latch hooks, built-in lubricators and air strainer, exhaust muffler

Optional Equipment at Extra Cost: chain container bucket C088945, additional chain lift and pendent control beyond standard lengths.

ATP Large Air Drills



ATP 2122 Series Drills

The 2122 series drills are designed for RUGGED HEAVY DUTY drilling, reaming, tapping and tube rolling applications in heavy fabrication, petrochemical, general industrial, and construction industries.

Features

- Ball bearing support for long life and smooth operation
- Roll throttle for excellent speed control
- Governor-controlled motor conserves air at light loads, holds speed at peak horse power under heavy loading
- Internal oil reservoir reduces “downtime”
- External grease fitting for easy lubrication
- Self closing roll throttle with independent reverse

Standard Equipment:

- Breast plate, assist handle, 1/2” shank, wood bore chuck

Optional Equipment:

- #2 and #3 morse tapers, 1/2” and 3/4” drill chucks

ATP 3500 Drills

3500 drills are used for extra heavy duty drilling, reaming, tapping and tube rolling applications in petrochemical, heavy fabrication, general industrial, shipbuilding and construction industries.

Features

- Reversible self-closing roll throttle for one-hand throttle control and reversing
- Governor controlled motor conserves air at light loads, holds speed at heavier loads while increasing power
- Heavy-duty ball bearings for long life
- 5.9 horse power motor and rugged gearing provides maximum power output
- Integral #4 and #5 morse taper female sockets for fast, easy change overs and positive drill bit retention
- Feed screw for drilling or reaming down force



2122-725WB

*Shown with optional 1/2” Drill Chuck and Morse Taper Spindle.



3500RAFYM

2122 Drill Specifications

Models	Free Speed RPM	Weight lb (Kg)	Height Over Spindle in (mm)	Side To Center Distance in (mm)	CFM	Spindle and Spindle Chuck	Air Inlet / Hose ID in (mm)
2122-725WB	725	14.4 (6.53)	17.25 (438)	1-7/16 (36)	50	Threaded, 1/2” Shank Wood Bit Chuck	1/2 NPT 3/4 (19)
2122-360-1/2	360	14.4 (6.53)	17.25 (438)	1-7/16 (36)	50	1/2” Chuck	1/2 NPT 3/4 (19)

Also available in 280 rpm, 350 rpm and 375 rpm models

3500 Drill Specifications

Models	Free Speed RPM	Weight lb (Kg)	Height Over Spindle in (mm)	Side To Center Distance in (mm)	CFM	Spindle and Spindle Chuck	Air In;et / Hose ID in (mm)
3500RAFUL	100	69 (31.4)	23.25 (591)	2.75 (69.9)	165	#4MT	1 NPT 1 (25)
3500RAFYM	60	69 (31.4)	23.25 (591)	2.75 (69.9)	165	#5MT	1 NPT 1 (25)

ATP Air Motors

Productivity in Motion



ATP Air Motors

Use ATP air motors whenever you need a rugged and reliable power source for the most demanding requirements. We offer a wide range of air motors to fit your needs.

- **ATP Air Motors are 100% U.S.A. Manufactured**
- **ATP can also custom design motors for your unique applications**

Contact ATP's customer service team for a motor quotation.



Features:

- *Optional 2 movement safety trigger*
- *Variable speed and torque control*
- *High output durable vane motor*
 - *Rugged planetary gearing*
 - *Mounts in any position*
 - *Keyed output shaft*

3400 Series Specifications

Models	Max Power		Speed at	Free Speed (RPM)	Starting Torque		Stall Torque		Air Consumption		Weight	
	(hp)	(kW)	Max. Power (RPM)		(ft lb)	(Nm)	(ft lb)	(Nm)	At Max. Power (CFM) (m3/m)	(lb)	(kg)	
CML 3460	1.14	.085	180	260	40	54	56	76	45	1.27	7.3	3.3
CML 3488	1.14	.085	90	130	85	115	110	149	45	1.27	7.3	3.3



Features:

- *Variable speed and torque control*
- *High output durable vane motor*
 - *Rugged planetary gearing*
 - *Keyed output drive shaft*
 - *Six hole face mounting*
 - *Mounts in any position*

3800 Series Specifications

Models	Max Power		Speed at	Free Speed (RPM)	Starting Torque		Stall Torque		Air Consumption		Weight	
	(hp)	(kW)	Max. Power (RPM)		(ft lb)	(Nm)	(ft lb)	(Nm)	At Max. Power (CFM) (m3/m)	(lb)	(kg)	
Non-Reversible (Direction of rotation is counterclockwise when facing the shaft end of motor)												
ATP 3800P	1.45	1.08	285	600	42	57.0	56.5	76.6	48	1.36	8.5	3.86
ATP 3800Q	1.45	1.08	180	375	62	84.0	83.5	113.0	48	1.36	8.5	3.86
ATP 3800R	1.45	1.08	150	320	72	98.0	96.0	130.0	48	1.36	8.5	3.86
ATP 3800S	1.45	1.08	120	255	88	119.0	118.0	160.0	48	1.36	8.5	3.86
ATP 3800U	1.45	1.08	105	220	105	142.0	140.0	189.0	48	1.36	8.5	3.86
Reversible												
ATP 3840P	1.35	1.01	215	440	40	54.2	53.5	72.6	44	1.25	8.75	3.97
ATP 3840Q	1.35	1.01	130	280	60	81.4	80.0	108.0	44	1.25	8.75	3.97
ATP 3840R	1.35	1.01	122	238	69	93.0	92.0	125.0	44	1.25	8.75	3.97
ATP 3840S	1.35	1.01	100	190	86	116.0	115.0	156.0	44	1.25	8.75	3.97
ATP 3840U	1.35	1.01	83	162	100	135.0	134.0	181.0	44	1.25	8.75	3.97

ATP Air Motors

Productivity in Motion



Features:

- Variable speed and torque control
- High output durable vane motor
 - Rugged planetary gearing
 - Keyed output drive shaft
 - Six hole face mounting
 - Mounts in any position

4800 Series Specifications

Models	Max Power		Speed at		Starting Torque		Stall Torque		Air Consumption		Weight	
	(hp)	(kW)	Max. Power (RPM)	Free Speed (RPM)	(ft lb)	(Nm)	(ft lb)	(Nm)	At Max. Power (CFM)	(m3/m)	(lb)	(kg)
Non-Reversible (Direction of rotation is counterclockwise when facing the shaft end of motor)												
ATP 4800K	3.7	2.76	821	1,538	35.3	47.8	47	63.7	95	2.69	15.25	6.92
ATP 4800M	3.7	2.76	560	1,050	51	69.2	69	93.6	95	2.69	15.25	6.92
ATP 4800N	3.7	2.76	387	726	75	102	100	136	95	2.69	15.25	6.92
ATP 4800P	3.7	2.76	260	510	98	133	131	178	95	2.69	19.75	9.0
ATP 4800Q	3.5	2.61	194	375	129	175	173	235	95	2.69	19.75	9.0
ATP 4800S	3.5	2.61	146	275	178	241	238	323	95	2.69	19.75	9.0
ATP 4800U	3.5	2.61	97	185	265	359	354	480	95	2.69	19.75	9.0
Reversible												
ATP 4840K	3.2	2.39	711	1,429	32	43.4	42.7	57.9	95	2.69	15.25	6.92
ATP 4840M	3.2	2.39	485	975	47.3	64	63	85.4	95	2.69	15.25	6.92
ATP 4840N	3.2	2.39	336	675	67.7	91.7	90.2	122	95	2.69	15.25	6.92
ATP 4840P	3	2.24	228	475	93	126	125	170	95	2.69	20.125	9.13
ATP 4840Q	3	2.24	167	350	123	167	165	224	95	2.69	20.125	9.13
ATP 4840S	3	2.24	125	255	161	218	215	292	95	2.69	20.125	9.13
ATP 4840U	3	2.24	83	170	225	305	300	407	95	2.69	20.125	9.13



Features:

- With or without reverse, CW or CCW rotation
- Custom designed for multiple applications
 - Keyed or tapered output drive shaft
 - Variable speed and torque control
 - High output durable vane motor
 - Fixture mount in any position
 - Rugged planetary gearing

7600 Series Specifications

Models	Max Power		Speed at		Starting Torque		Stall Torque		Air Consumption		Weight	
	(hp)	(kW)	Max. Power (RPM)	Free Speed (RPM)	(ft lb)	(Nm)	(ft lb)	(Nm)	At Max. Power (CFM)	(m3/m)	(lb)	(kg)
7667-400	.45	.34	210	400	11.3	15.3	22	29.8	25	.71	2.5	1.13
7667-600	.45	.34	425	600	6.4	8.68	11	14.9	25	.71	2.5	1.13
7667-1000	.45	.34	600	1,000	4.8	6.5	7.5	10.2	25	.71	2.5	1.13

ATP Air Motors

Productivity in Motion



Features:

- Variable speed and torque control
- High output durable vane motor
 - Keyed output shaft
 - Flange mounts

318 Series Specifications

Models	Max Power		Speed at Max. Power		Torque @ Max power		Stall Torque		Air Consumption At Max. Power		Weight	
	(hp)	(kW)	(RPM)	Free Speed (RPM)	(ft lb)	(Nm)	(ft lb)	(Nm)	(CFM)	(m3/m)	(lb)	(kg)
318-RSM3000	2.90	2.16	3,450	*	4.5	6.10	9.0	12.20	135	3.80	20	9.07
318-RSM300	2.90	2.16	370	*	42.0	57.0	75.0	101.69	45	1.27	35	15.88
318-RSM125	2.90	2.16	155	*	99.0	134.23	175.0	237.27	135	3.80	60	27.22
318-RSM40	2.90	2.16	59	*	262.50	356.0	525.0	711.80	135	3.80	60	27.22

* Ungoverned stationary motors must be use in applications where the motor will always run under load.



Features:

- Variable speed and torque control
- High output durable vane motor
 - Rugged spur gearing
 - Keyed output shaft
 - Foot mounting

3501 Series Specifications

Models	Max Power		Speed at Max. Power		Torque @ Max Power		Stall Torque		Air Consumption At Max. Power		Weight	
	(hp)	(kW)	(RPM)	Free Speed (RPM)	(ft lb)	(Nm)	(ft lb)	(Nm)	(CFM)	(m3/m)	(lb)	(kg)
3501-RSM3600	7.0	5.22	3,500	7,100	10.0	13.56	17.0	23.05	190	5.38	26	11.79
3501-RSM1800	7.0	5.22	1,590	3,180	23.0	31.18	38.0	51.52	190	5.38	65	29.48
3501-RSM1000	7.0	5.22	900	1,820	41.0	55.59	68.0	92.20	190	5.38	65	29.48
3501-RSM400	7.0	5.22	350	710	105.0	142.36	175.0	237.27	190	5.38	65	29.48
3501-RSM310	7.0	5.22	280	570	130.0	176.26	220.0	298.28	190	5.38	65	29.48
3501-RSM200	7.0	5.22	185	370	200.0	271.16	330.0	447.42	190	5.38	65	29.48
3501-RSM150	7.0	5.22	150	275	245.09	332.30	450.0	610.12	190	5.38	65	29.48
3501-RSM100	7.0	5.22	99	180	347.0	470.47	620.0	840.61	210	5.95	77	34.93
3501-RSM60	7.0	5.22	52	95	710.0	962.63	1,200.0	1,626.98	210	5.95	77	34.93

Jet Air Fan “Moving More Air by Design”

ATP-JA20 High Performance Air Mover

ATP's JET AIR produces superior air flow. Thanks to the engineering of our trailing edge design, the blades pull more air through the fan in the forward direction like a Jet Prop. The result, we move more air at lower fan speeds using less energy than the competition does!

Features:

- Used for general ventilation where compressed air power source is available
- Designed for fixtured applications, easily mounting to a 20" API flange
- Dynamically balanced 4 blade design for smoother operation
- High visibility orange - powder coated stainless steel fan shroud for safety
- Manufactured to aircraft tolerances & specifications
- Moves more air by design, at air pressures between 40-110 psi (2.75 - 7.6 bar)
- Reduces air turbulence by design, smoother air flow at all RPM's using only 2 rotating parts
- Hy-Tech bearing grease used in all high speed Jet Air Bearings
- Can be used as a blower or exhauster by turning it around



Ventilation Applications and Industries:

- Removal of hazardous fumes from tanks, process vessels, welding, sandblasting and other operations in confined areas
- Used in Refineries, Chemical Plants, Shipyards, Power Generation, Paper Mills and Steel Fabrication Plants

Specifications:

- Fan assembly shaft rotates on permanently sealed ball bearings
- Air consumption at 60 PSI, 115 CFM @ 2,700 RPM
- Fits 20" (508 mm) API tank opening bolt circle
- Delivery - up to 11,200 CFM (19,029 m3/hr)
- Max 120 PSI, Working pressure 40-110 PSI
- Weight 103 lbs (Shipping weight 113 lbs)
- Mounting slots 1-1/8" diameter
- Air inlet 3/4" NPT
- Rebuild Kit: JA20RK
- Grounding Clamp: JA20GC

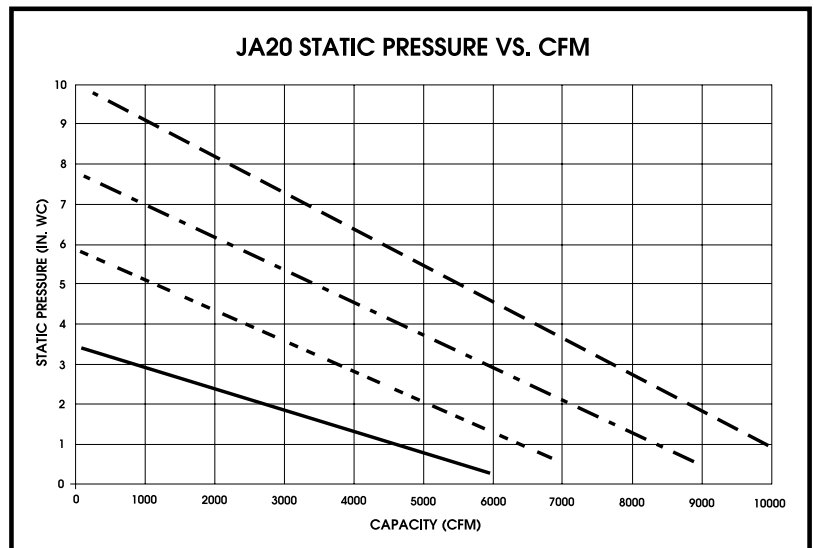

ATP Venturi Air Movers “Air Horns”



Features:

- Used for portable ventilation where compressed air is available as a power source
- Rugged “Tech-Alloy” aluminum casting
- No moving parts to replace
- Periodic steam cleaning for easy maintenance
- Can pull air from confined areas or blow fresh air into area
- Grounding wire and clamp - standard equipment
- Will operate on compressed air or steam

Ventilation Applications and Industries:

- Removal of hazardous fumes from tanks, process vessels, welding, sandblasting and other operations in confined areas
- Cooling personnel, machinery or production product with a blast of air
- Used in Refineries, Chemical Plants, Shipyards, Power Generation, Paper Mills and Steel Fabrication Plants

Models	Length in (mm)	Base Diameter in (mm)	Top Diameter in (mm)	Air Inlet in	Weight lb (kg)	CFM Flow @ 80 PSI	CFM Used @ 80 PSI
3VAMS	16.75 (425.5)	7.31 (185.7)	6.0 (152.4)	1/2 NPT	5.5 (2.5)	1,180	65
3VAM	30.5 (774.7)	7.31 (185.7)	7.0 (178.0)	1/2 NPT	8.5 (3.8)	1,450	65
6VAM	44.25 (1124.0)	11.25 (285.8)	12.5 (317.5)	1 NPT	22.0 (9.9)	3,350	125
8VAM	46.0 (1168.4)	14.37 (365.0)	14.25 (362.0)	1 NPT	36.0 (16.3)	4,930	195
1OVAM	48.0 (1219.2)	17.0 (432.0)	15.75 (400.05)	1 NPT	42.0 (19.05)	7,300	275

Strict precautions may be required when using any air horn. To reduce the risk of injury, all operators and maintenance personnel must read and follow the safety instructions before operating the air horns. Failure to read and follow the safety instructions could result in serious injury or death. **Product Safety Note:** Always attach a grounding cable. Grounding clamp and wire must be used to prevent static electricity build up which could cause a spark.

ATP Air Tool Lubricants

Oil and Grease



ATP Ice Free “BLUE MAGIC” Air Tool Lubricant For Pneumatic Tools

This oil is especially compounded for lubricating Air Impact Tools, Hammers, Drills, Grinders, Pumps, Breakers, Air Motors and other Pneumatic Tools. Moisture in compressed air will rapidly wash away most lubricating oils used in air tools. “BLUE MAGIC” oil, has additives that absorb such moisture into the lubricant, forming a stable emulsion which clings to the inside of the tool. It not only lubricates and rustproofs, but it prevents “ice” from forming in the tool’s exhaust, and is good to -40 degrees F reducing the need for most cold weather air line additives. During idle time, there is no separation of moisture and oil. This constantly maintained protective film prevents rust and corrosion in the inside of air tools.

IMPORTANT:

When using “BLUE MAGIC” Ice Free Oil in Air Line Lubricators, adjust the feed rate to approximately 1/3 of that used with regular oil. “BLUE MAGIC” oil does not wash out of air tools as rapidly as regular oils do.

Blue Magic Oil

Models	Container Size	Case Quantity
P-137646	Pint	24
P-137145	Quart	12
P-089507	Gallon	4

Sold as each



Impact Mechanism (Clutch) Lubricant “Pure Gold”

A superior synthetic moly-based extreme pressure lubricant for use in all types of grease lubricated impact mechanisms, anvil bushings and high speed air motor bearings.

Pure Gold Lubricant

Models	Container Size
CA-131898	14.5 oz Cartridge
C-131689	7-1/2 lb Pail



ATP Air Line Accessories

ATP Automatic In-line Oilers

The ATP (football type) automatic in-line oilers are designed to supply oil for tool lubrication anywhere stationary lubricators are not feasible to use. Automatic in-line oilers should be installed as close to the air tool as possible. The ATP automatic in-line oilers have an adjustable needle valve flow control to permit easy regulation of oil flow. Oil flow while using ATP's ice free "BLUE MAGIC" air tool lubricant should be set at approximately one drop per minute. The rugged cast housing provides long service life under the most severe service conditions.



ATP OL

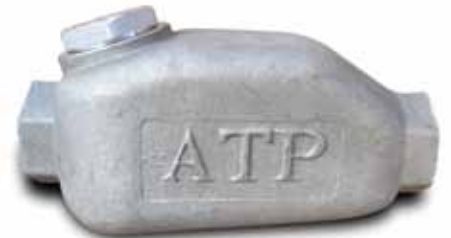

ATP 1L



ATP 2L



ATP 3L

In-line Oiler Specifications

Models	Thread NPT/Hose Barb Pipe in	Max. Working Pressures (PSI)	Recommended Oil Wt./Capacity (FL. OZ.)
ATP OL	1/2 NPT	500	ATP Blue Magic/5 Wt. 1.4 Fl. Oz.
ATP 1L	3/4 NPT	260	ATP Blue Magic/5 Wt. 4.0 Fl. Oz.
ATP 2L	3/4 NPT	300	ATP Blue Magic/5 Wt. 11.0 Fl. Oz.
ATP 3L	1 NPT	250	ATP Blue Magic/5 Wt. 16.0 Fl. Oz.

Repair kit for in-line oiler ATP-LRK

ATP Air Line Accessories

Sahara Moisture Separator With Automatic Drain

Features

- Removes 100% of visible moisture from air lines
- Will pass 180 CFM through 3/4" NPT fittings at 90 PSI
- Can be mounted on a portable frame
- No need for changing filter units
- Suitable for up to 100 PSI
- No moving parts



Model	Inlet in	Outlet in	Rated Pressure
S7F	3/4 NPT	3/4 NPT	100 PSI or 7 BAR

Weight: 11 lbs

Dimensions: 6" Dia. x 9.5"

Sahara Separator Installation

Air Flow

Compressed air enters the separator with moisture in the air.

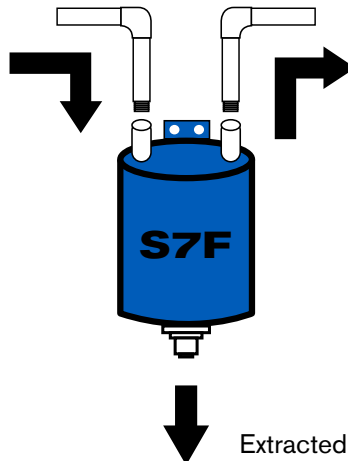

Compressed air leaves separator free of moisture supplied to tools and other air powered equipment.

Extracted moisture collected in the sump is dissipated through a drain valve.

ATP Whip Hoses

ATP whip hoses are made of high strength and durable hydraulic hose, with 360° inlet swivels, in-line oilers, and Chicago quick connect fittings. Whip hoses are 6' in total length.



Whip Hose Specifications

Models	Tool Inlet Size in	Hose Size in
WH-4	1/4 Inlet	1/2
WH-6	3/8 Inlet	1/2
WH-5	1/2 Inlet	1/2

ATP Air Line Accessories



Standard Universal Hose Couplings

ATP Universal Hose Couplings are a rugged rust proof one-piece design with the convenience of a quarter turn connect/disconnect feature. The design increases holding power and seal with increase in air pressure. The gaskets will not blow or fall out. The same size coupling end is used on all sizes making for easy interchange of different size hose assemblies. The coupling gaskets are made of high grade materials that retain their effective resiliency indefinitely. Gaskets are easily installed using only your fingers. No special tools are required for installation!



WARNING: ALWAYS use a coupling lock pin (part number C-142110) to prevent injury from accidental uncoupling of universal hose couplings. Whip hoses can cause serious injury!

Special Large Size Universal Couplings:

These have the same advantages of the Standard Universal Couplings except there is no interconnect ability with standard sizes.



Bronze Models	Description
C-015145 1-1/2	NPT Male Pipe Thread
C-015175 1-1/2	NPT Female Pipe Thread
C-015176 1-1/2	Diameter Hose I.D.

Rubber gasket for large Universal Couplings, C-015071
 *One gasket supplied with each coupling

Coupling Accessories

Dead End Cap	C-035019
3 Way Coupling	C-035021
Rubber Gasket	C-035138

Male Thread Coupling

Bronze Models	NPT Male Pipe Thread in
C-015123	3/8
C-015122	1/2
C-015121	3/4
C-015120	1

Female Thread Coupling

Bronze Models	NPT Female Pipe Thread in
C-015128	3/8
C-015127	1/2
C-015126	3/4
C-015125	1

Hose End Coupling

Bronze Models	Hose I.D. in
C-015134	3/8
C-015132	1/2
C-015131	3/4
C-015130	1



Air Tool Replacement Parts



The Performance Upgrade: Fix It To Last.

In addition to spare parts for ATP and Thor brands, we also manufacture many replacement parts for Ingersoll Rand, Chicago Pneumatic, Cleco, Top Cat, Sullair, and other leading brands.

Our products have been manufactured in the U.S.A. since 1923 and engineered at or above the most current OEM specifications and standards producing;

- Less down time
- Fewer change outs
- Reduced maintenance costs

Repairing your tools with high quality ATP replacement parts gives you the confidence your tools will get the job done.

With over **20,000** OEM part numbers in stock, the next time you need quality replacement parts, demand ATP.



ATP Air Tool Tune Up Kits



ATP Tune Up Kits

ATP Tune Up Kits contain those items which are essential to a professional tool Tune-Up, and assures maximum productivity and utilization of your tools. Selected vanes, bearings, gaskets, and seals are packaged for ease of use and storage.

PART #	FITS MODELS
C-101077	CP20
C-101083	CP3440
C-101088	CP606
C-101089	CP610
C-101090	CP612
C-101091	CP365
C-101614	CP614
C-101987	CP6120
C-115811	CP611
C-118984	CP606
C-119108	CP612
C-132252	CP365
C-137568	CP6060
CA-131501	CP797
1710B/1710P-TK3	IR1710
1712B/1712P-TK3	IR1712
1720B-TK2	IR1720B
1720P-TK2	IR1720P
261-TK2	IR261
2906P-TK1	IR2906P
2908-TK1	IR2908
2908P-TK2	IR2908P
2910-TK4	IR2910
2920B-TK2	IR2920B
2920P-TK2	IR2920P
2921P-TK2	IR2921P
2925-TK2	IR2925
2934-TK3	IR2934
2940-TK3	IR2940
2945-TK2	IR2945
2950-TK2	IR2950
3940-TK1	IR3940
3941-TK1	IR3941
3942-TK1	IR3942
3955-TK1	IR3955
599-TK1	IR599
99V/99H-TK3	IR99V & IR99H Grinders
270-1700	ATSCO V3000 Grinders
270-1900	ATSCO V4000 Grinders
270-2500	ATSCO A712S & 725S Die and Angle Grinders
270-6500	ATSCO 1200 Series Horizontal Grinders



Super Strength Impact Sockets.
Striking Wrenches and Accessories

WORLD'S MOST EXTENSIVE PRODUCT LINE

ELECTRO CHEMICALLY MACHINED (ECM)

LESS STRESS DESIGN



OZAT is a Division of Hy-Tech Machine, Inc.

Electro Chemically Machined (ECM):

Electro Chemical Machining (ECM) is a process in which electrical and chemical energy sources are used for efficient and cost-effective metal removal. The process features:

- Fast machining of complex geometries and hard metals
- Smooth surface finishing
- Stress-free performance
- Absence of thermal strain
- High accuracy
- Automatic deburring

Sockets Are Fully Machined From Bar Stock

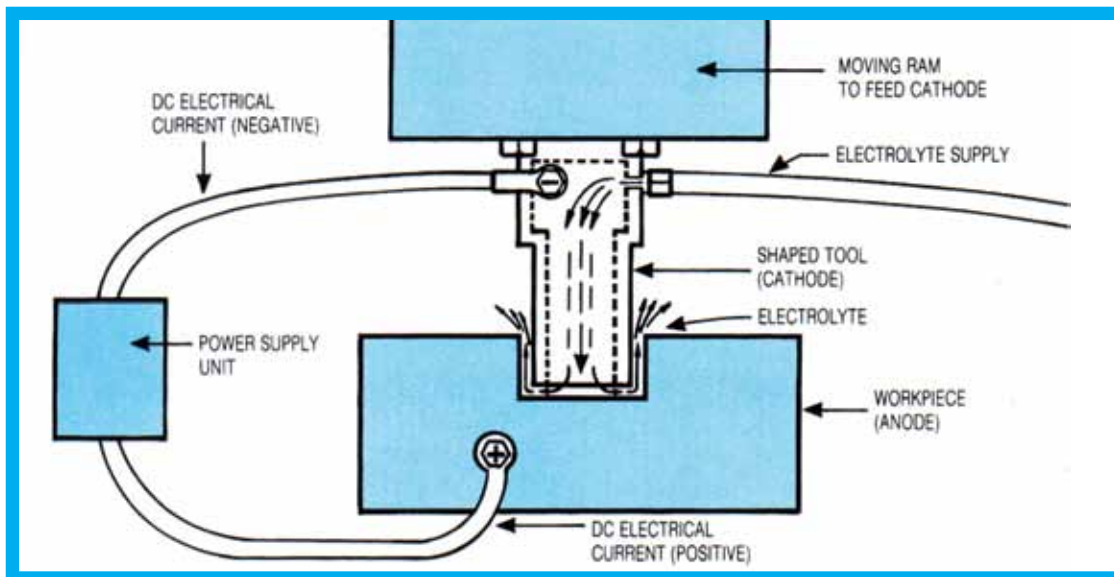

ECM Process Illustration

The cathode tool is shaped to provide the form desired in the work-piece. A low voltage is delivered by the power supply unit and an electrolyte is pumped under high pressure between the tool and the work-piece. A mechanically driven ram feeds the tool at a consistent rate into the work-piece to machine the desired shape or cavity.



Less Stress Design:

OZAT socket design is clearly superior to most other sockets available. Their state of the art electro-chemically machined process makes it possible for OZAT to produce all of their sockets in the **less-stress™** design illustrated below.

Without these special machining capabilities, cost of producing the preferred less-stress sockets becomes prohibitive. While other manufacturers, who use the normal broaching method to achieve the hex pattern in their sockets, may have to compromise in their selection of suitable steel, OZAT is able to specify the most perfectly matched material from which to manufacture the most durable and reliable sockets available.

The OZAT difference results in longer socket and fastener life and cost savings to the user.

OZAT VS. OTHER SOCKETS

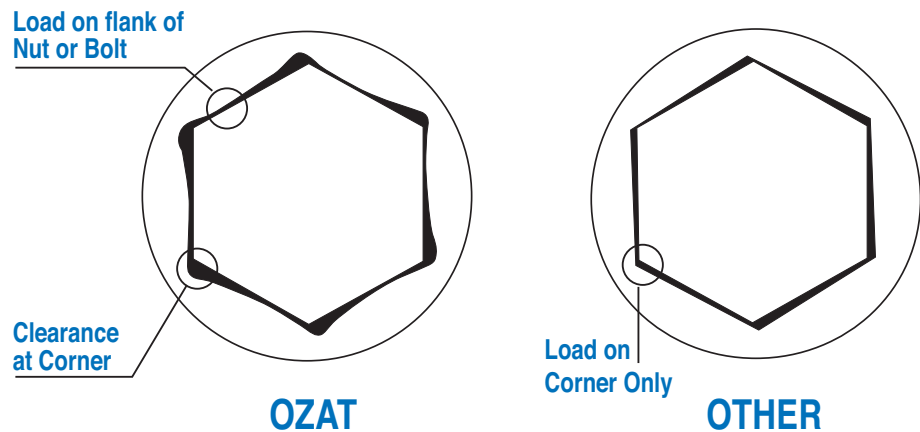

Availability:

ATP / OZAT Sockets are available in 1/2" through 3-1/2" Square Drive and in #4 and #5 Spline sizes, in 4 point, 6 point, 8 point, 12 point, Standard depth, Deep length, Thin walls, Hex bit, "In-Star" type bits, Magnetic bits, Railroad sockets and Torsion bars.

Custom sockets quoted upon request, see page 83.

Statement of Warranty:

The OZAT warranty provides for free replacement, to the original purchaser, of any qualifying socket found to be defective in either material or workmanship, as indicated by breakage or premature wear. Determination of free replacement will be made after examination by ATP. Impact sockets, by their application, are subject to extreme stresses. Therefore special application sockets such as thinwall, hex driver, In-Star driver, and accessories are specifically excluded from the replacement warranty.

Products returned to ATP for warranty consideration must be shipped prepaid, with an ATP returned goods authorization (RGA) number issued by the customer service department. ATP/OZAT impact sockets and accessories are available exclusively through leading industrial distributors nationwide.

For the name of a distributor in your area contact ATP at 1-800-245-1148.

1/2 Inch Square Drive	41
Six Point Impact Sockets	
In-star Drivers & Sockets	
Hex Driver and 12 Point Sockets	
Ret Rings	
Power Line Utility Sockets	
5/8 Inch Square Drive	48
Six Point Impact Sockets	
Accessories	
3/4 Inch Square Drive	50
Six Point Impact Sockets	
BUDD Wheel Sockets	
Hex Driver Sockets	
Double Square Impact Sockets	
12 Point Sockets	
Accessories	
Railroad Sockets	57
1 Inch Square Drive	58
Six Point Impact Sockets	
Hex Driver Sockets	
Double Square Impact Sockets	
BUDD Wheel Sockets	
12 Point Sockets	
Accessories	
1-1/2 Inch Square Drive	65
Six Point Impact Sockets	
12 Point Sockets	
Accessories	
2-1/2 Inch Square Drive	70
Six Point Impact Sockets	
Accessories	
3-1/2 Inch Square Drive	74
Six Point Impact Sockets	
Accessories	
#5 Spline Drive	76
#4 Spline Sockets & Universal Joint	78
Six Point Impact Sockets	
74BUDD Wheel Sockets	
Accessories for #5 Spline Drive	
Flat Striking Wrenches (12 Point Opening)	79
Offset Striking Wrenches (12 Point Opening)	81
Striking Wrench Adapter	81
Torque Multipliers	82
Request for Quote (Special Socket Order)	83



Safety For Productivity

- Users and bystanders must wear safety glasses conforming to ANSI Z87.1
- Do not hold sockets, extensions, and accessories while impacting or powering to avoid injury
- ¾" drive and larger sizes require the use of ret rings or a Pin & O-ring to secure the socket to the drive
- Never use a nail or homemade pin to secure a socket to a drive
- Never exceed the manufacturer's air tool pressure rating, and hydraulic pressure rating
- Never use a hand chrome socket for impacting or striking applications
- Impact sockets are used to tighten or loosen fasteners powered by air, hydraulic or electric tools
- Never dwell on a socket after it has stopped turning, this can damage both the socket and fastener
- Ensure the socket is fully engaged on the fastener before activating the power tool source
- Impact adapter strength is limited to the smallest drive size or connection point
- Always limit the joints and extensions between the socket and power tool to reduce failure
- Sockets must be properly sized and fitted to the fastener prior to use
- Large drive impact sockets are inherently heavy and care needs to be taken in handling
- Socket openings need to be inspected before each use, and discarded if significant wear or deterioration is present
- Inspect and discard worn or cracked sockets at the drive opening and across the flats
- Striking wrenches must be properly sized and fitted to the fastener prior to use
- Striking to the wrench should only occur on the striking lug end, opposite the fastener engaged end
- Operators hand must be as far away from the striking lug during striking
- Striking wrench must be fully engaged on the fastener prior to striking
- The linear surface on a flat or offset striking wrench must be a true horizontal axis prior to striking
- Striking wrenches must be inspected prior to each use, and discarded if significant wear, cracks or other damage is visually evident across the flats and striking lug surface
- Large size striking wrenches are inherently heavy and care needs to be taken in handling



1/2" SQUARE DRIVE

SIX POINT IMPACT SOCKETS

OZAT 1/2" Drive impact sockets are preferred in many industrial applications where long lasting sockets are required for severe applications. From assembly lines to plant maintenance to busy tire shops, OZAT sockets reduce cost and downtime.

Standard Fractional Sizes

SIZE in	PART#	D1 in	D2 in	L in	T in	C in
3/8	Z-0806	.630	.984	1.482	.157	.595
7/16	Z-0807	.748	.984	1.482	.236	.595
1/2	Z-0808	.787	.984	1.482	.236	.674
9/16	Z-0809	.866	.984	1.482	.276	.674
5/8	Z-0810	.984	1.181	1.482	.315	.753
11/16	Z-0811	1.102	1.181	1.482	.354	.753
3/4	Z-0812	1.102	1.181	1.482	.335	.753
13/16	Z-0813	1.181	1.181	1.482	.433	.832
7/8	Z-0814	1.181	1.181	1.482	.512	.91
15/16	Z-0815	1.378	1.181	1.482	.512	.91
1	Z-0816	1.496	1.181	1.482	.512	.95
1-1/16	Z-0817	1.496	1.181	1.950	.512	.95
1-1/8	Z-0818	1.614	1.181	1.560	.643	1.107
1-3/16	Z-0819	1.614	1.181	1.950	.643	1.107
1-1/4	Z-0820	1.732	1.378	1.560	.669	1.107
1-5/16	Z-0821	1.732	1.378	1.677	.748	1.186
1-3/8	Z-0822	1.929	1.378	1.560	.748	1.265
1-7/16	Z-0823	1.929	1.732	1.950	.748	1.265
1-1/2	Z-0824	2.047	1.732	1.950	.846	1.344

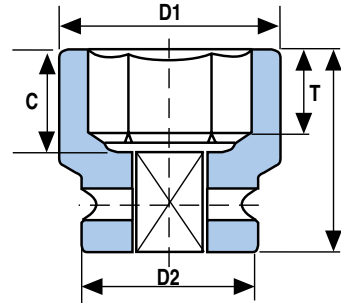

Deep Fractional Sizes

SIZE in	PART#	D1 in	D2 in	L in	T in	C in
3/8	Z-0806L	.630	.984	3.042	.157	2.721
7/16	Z-0807L	.748	.984	3.042	.236	2.721
1/2	Z-0808L	.787	.984	3.042	.236	2.721
9/16	Z-0809L	.866	.984	3.042	.276	2.721
5/8	Z-0810L	.984	1.181	3.042	.315	2.721
11/16	Z-0811L	1.102	1.181	3.042	.354	2.721
3/4	Z-0812L	1.102	1.181	3.042	.335	2.721
13/16	Z-0813L	1.181	1.181	3.042	.433	2.721
7/8	Z-0814L	1.181	1.181	3.042	.512	2.721
15/16	Z-0815L	1.378	1.181	3.042	.512	2.721
1	Z-0816L	1.496	1.181	3.042	.512	2.721
1-1/16	Z-0817L	1.496	1.181	3.042	.512	2.721
1-1/8	Z-0818L	1.614	1.181	3.042	.643	2.721
1-3/16	Z-0819L	1.614	1.181	3.042	.643	2.721
1-1/4	Z-0820L	1.732	1.378	3.042	.669	2.721
1-5/16	Z-0821L	1.732	1.378	3.042	.748	2.721
1-3/8	Z-0822L	1.929	1.378	3.042	.748	2.721
1-7/16	Z-0823L	1.929	1.732	3.042	.748	2.721
1-1/2	Z-0824L	2.047	1.732	3.042	.846	2.721

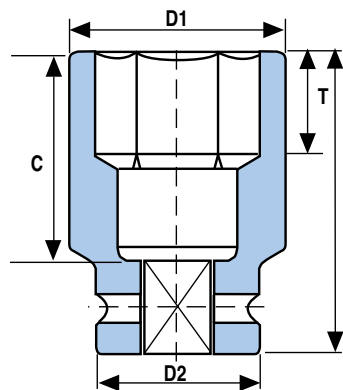

Standard Fractional Thinwall Sizes

SIZE in	PART#	D1 in	D2 in	L in	T in	C in
9/16	Z-0809T	.866	.984	1.482	.551	.700
5/8	Z-0810T	.984	.984	1.482	.551	.750
11/16	Z-0811T	.984	.984	1.482	.551	.750
3/4	Z-0812T	1.102	1.181	1.482	.551	.750
13/16	Z-0813T	1.102	1.181	1.482	.551	.780
7/8	Z-0814T	1.181	1.181	1.482	.551	.780
15/16	Z-0815T	1.299	1.181	1.482	.551	.810

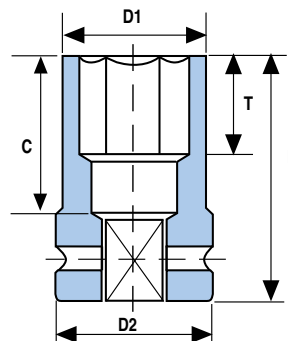

1/2" SQUARE DRIVE

SIX POINT IMPACT SOCKETS

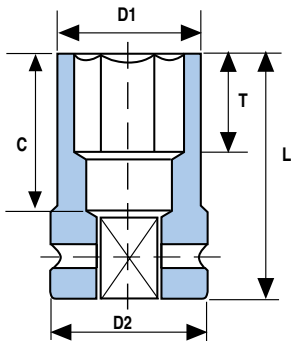
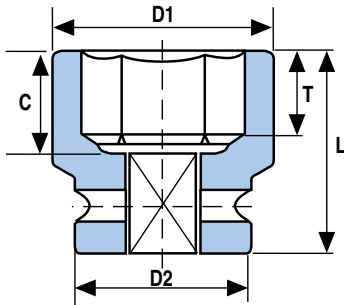
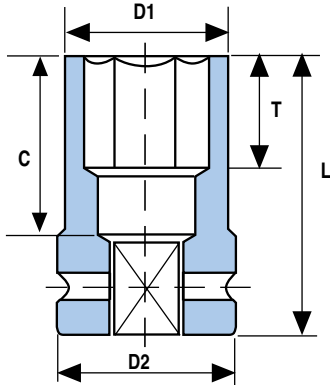

Deep Fractional Thinwall Sizes

SIZE in	PART#	D1 in	D2 in	L in	T in	C in
9/16	Z-0809LT	.866	.984	3.042	.551	2.721
5/8	Z-0810LT	.984	.984	3.042	.551	2.721
11/16	Z-0811LT	.984	.984	3.042	.551	2.721
3/4	Z-0812LT	1.102	1.181	3.042	.551	2.721
13/16	Z-0813LT	1.102	1.181	3.042	.551	2.721
7/8	Z-0814LT	1.181	1.181	3.042	.551	2.721
15/16	Z-0815LT	1.299	1.181	3.042	.551	2.721

Standard Metric Sizes

SIZE mm	PART#	D1 mm	D2 mm	L mm	T mm	C mm
8	Z-08M8	15	25	38	4	15
9	Z-08M9	16	25	38	4	15
10	Z-08M10	17	25	38	5	15
11	Z-08M11	19	21	38	5	15
12	Z-08M12	20	25	38	6	17
13	Z-08M13	21	25	38	6	17
14	Z-08M14	22	25	38	7	17
15	Z-08M15	24	30	38	7	19
16	Z-08M16	25	30	38	7	19
17	Z-08M17	26	30	38	9	19
18	Z-08M18	28	30	38	9	19
19	Z-08M19	28	30	38	9.5	19
20	Z-08M20	30	30	38	10	21
21	Z-08M21	30	30	38	10	21
22	Z-08M22	33	30	38	10	21
23	Z-08M23	35	30	38	12	23
24	Z-08M24	35	30	45	12	23
25	Z-08M25	35	30	45	13	24
26	Z-08M26	38	5	50	13	24
27	Z-08M27	38	35	50	13	24
28	Z-08M28	38	35	50	14	25
29	Z-08M29	41	35	50	14	28
30	Z-08M30	41	35	50	16.5	28
31	Z-08M31	44	35	50	16.5	28
32	Z-08M32	44	35	50	16.5	28
33	Z-08M33	44	35	50	17	28
34	Z-08M34	49	35	46	17	30
35	Z-08M35	49	35	50	19	31
36	Z-08M36	49	44	50	19	31
37	Z-08M37	52	44	47	19	31
38	Z-08M38	52	44	50	22	34

Standard Metric Thinwall Sizes

SIZE mm	PART#	D1 mm	D2 mm	L mm	T mm	C mm
13	Z-08M13T	21	25	38	6	18
14	Z-08M14T	22	25	38	7	18
15	Z-08M15T	24	30	38	7	19
16	Z-08M16T	25	30	38	7	19
17	Z-08M17T	25	30	38	9	19
18	Z-08M18T	25	30	38	9	19
19	Z-08M19T	28	30	38	9	19
20	Z-08M20T	28	30	38	10	20
21	Z-08M21T	30	30	38	10	20
22	Z-08M22T	30	30	38	10	20
23	Z-08M23T	33	30	38	12	20
24	Z-08M24T	33	30	45	12	20

Deep Metric Sizes

SIZE mm	PART#	D1 mm	D2 mm	L mm	T mm	C mm
8	Z-08M8L	15	25	78	4	69
9	Z-08M9L	16	25	78	4	69
10	Z-08M10L	17	25	78	5	69
11	Z-08M11L	19	25	78	5	69
12	Z-08M12L	20	25	78	6	69
13	Z-08M13L	21	25	78	6	69
14	Z-08M14L	22	25	78	7	69
15	Z-08M15L	24	30	78	7	69
16	Z-08M16L	25	30	78	7	69
17	Z-08M17L	26	30	78	9	69
18	Z-08M18L	28	30	78	9	69
19	Z-08M19L	28	30	78	9.5	69
20	Z-08M20L	30	30	78	10	69
21	Z-08M21L	30	30	78	10	69
22	Z-08M22L	33	30	78	10	69
23	Z-08M23L	35	30	78	12	69
24	Z-08M24L	35	30	78	12	69
25	Z-08M25L	35	30	78	13	69
26	Z-08M26L	38	35	78	13	69
27	Z-08M27L	38	35	78	13	69
28	Z-08M28L	38	35	78	14	69
29	Z-08M29L	41	35	78	14	69
30	Z-08M30L	41	35	78	16.5	69
31	Z-08M31L	44	35	78	16.5	69
32	Z-08M32L	44	35	78	16.5	69
33	Z-08M33L	44	35	78	17	69
34	Z-08M34L	49	35	78	17	69
35	Z-08M35L	49	35	78	19	69
36	Z-08M36L	49	44	78	19	69
37	Z-08M37L	52	44	78	19	69
38	Z-08M38L	52	44	78	22	69

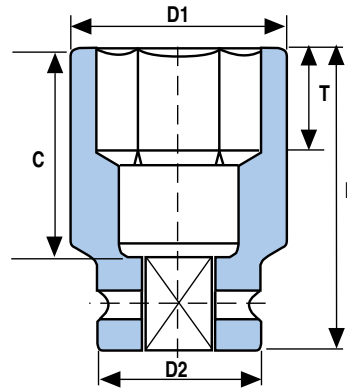

Deep Metric Thinwall Sizes

SIZE mm	PART#	D1 mm	D2 mm	L mm	T mm	C mm
13	Z-08M13LT	21	25	78	6	69
14	Z-08M14LT	22	25	78	7	69
15	Z-08M15LT	24	30	78	7	69
16	Z-08M16LT	25	30	78	7	69
17	Z-08M17LT	25	30	78	9	69
18	Z-08M18LT	25	30	78	9	69
19	Z-08M19LT	28	30	78	9	69
20	Z-08M20LT	28	30	78	10	69
21	Z-08M21LT	30	30	78	10	69
22	Z-08M22LT	30	30	78	10	69
23	Z-08M23LT	33	30	78	12	69
24	Z-08M24LT	33	30	78	12	69

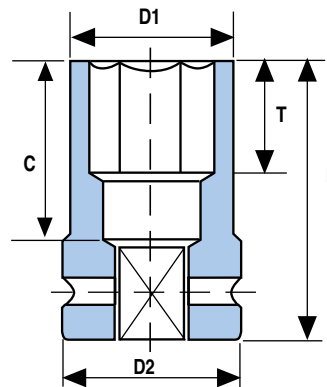

1/2" SQUARE DRIVE

HEX DRIVER SOCKETS

Bit Holders

PART#	DESCRIPTION
Z-08H11	1/2" Sq. x 11mm Hex Bit Holder
Z-08H16	1/2" Sq. x 16mm Hex Bit Holder

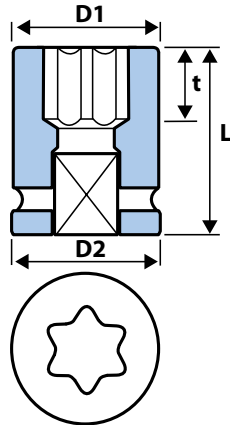

In-Star Impact Socket Sizes

TORX®	PART#	D1 mm	D2 mm	L mm	T mm	WEIGHT gr
E10	Z-08E10	15	25	38	9	85
E11	Z-08E11	15.5	25	38	9	85
E12	Z-08E12	16	25	38	10	91
E14	Z-08E14	18.5	25	38	12	91
E16	Z-08E16	20	25	38	12	95
E18	Z-08E18	22	25	38	12	95
E20	Z-08E20	25	30	38	13	140
E22	Z-08E22	26.5	30	45	15	158
E24	Z-08E24	28.5	30	45	17	161

In-Star Socket Driver Sizes

TORX®	PART#	D2 mm	L mm	T mm	Weight gr	REPLACEMENT TORX® BIT	BIT DESCRIPTION
T30	Z-08T30	25	57	3.19	110	HT30	11 mm HEX x 30
T40	Z-08T40	25	57	3.3	110	HT40	11 mm HEX x 40
T50	Z-08T50	25	57	4.57	110	HT50	11 mm HEX x 50
T55	Z-08T55	25	57	5.08	110	HT55	16 mm HEX x 55
T60	Z-08T60	30	60	7.62	160	HT60	16 mm HEX x 60
T70	Z-08T70	30	60	8.89	170	HT70	16 mm HEX x 70

TORX® is a Registered Trademark of Cam Car

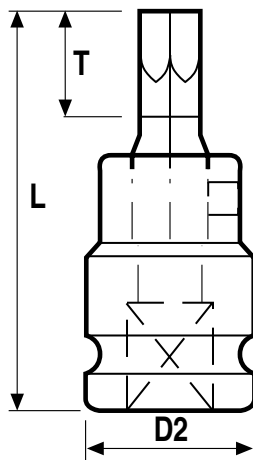

1/2" SQUARE DRIVE

HEX DRIVER SOCKETS

Fractional Sizes

SIZE in	PART#	D2 in	L in	T in
1/8	Z-0802H	.984	1.716	.748
5/32	Z-08005H	.984	1.716	.748
3/16	Z-0803H	.984	1.716	.748
7/32	Z-08007H	.984	1.716	.748
1/4	Z-0804H	.984	1.716	.748
5/16	Z-0805H	.984	1.716	.748
3/8	Z-0806H	.984	1.833	.866
7/16	Z-0807H	.984	1.950	.984
1/2	Z-0808H	1.181	1.950	.984
9/16	Z-0809H	1.181	1.950	.984
5/8	Z-0810H	1.181	1.950	.984

Note: 1 piece construction

Metric Sizes

SIZE mm	PART#	D2 mm	L mm	T mm
3	Z-08M3H	25	44	19
4	Z-08M4H	25	44	19
5	Z-08M5H	25	44	19
6	Z-08M6H	25	44	19
8	Z-08M8H	25	44	19
10	Z-08M10H	25	47	22
12	Z-08M12H	30	50	25
14	Z-08M14H	30	50	25
17	Z-08M17H	30	50	25
19	Z-08M19H	33	50	25

Note: 1 piece construction

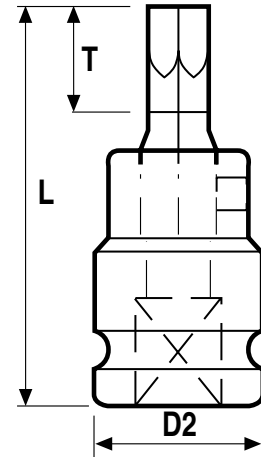

2-Part In-Hex Sizes

HEX in	HEX mm	PART#	D2 mm	L mm	T mm	Weight gr	REPLACEMENT HEX BIT
1/8		Z-0802V	25	54	6	90	H02
5/32		Z-08025V	25	54	6	90	H025
3/16		Z-0803V	25	54	8	90	H03
7/32		Z-08035V	25	54	9	90	H035
1/4		Z-0804V	25	57	12	100	H04
5/16		Z-0805V	25	57	12	100	H05
3/8		Z-0806V	25	57	16	100	H06
7/16		Z-0807V	25	57	18	100	H07
1/2		Z-0808V	30	57	19	150	H08
9/16		Z-0809V	30	57	21	150	H09
5/8		Z-0810V	30	57	24	150	H10
	3	Z-08M03V	25	54	5	90	HM03
	4	Z-08M04V	25	54	6	90	HM04
	5	Z-08M05V	25	54	8	90	HM05
	6	Z-08M06V	25	54	9	100	HM06
	8	Z-08M08V	25	57	12	100	HM08
	10	Z-08M10V	25	57	16	100	HM10
	12	Z-08M12V	30	57	18	150	HM12
	14	Z-08M14V	30	57	21	150	HM14
	17	Z-08M17V	30	57	26	150	HM17
	19	Z-08M19V	30	72	26	150	HM19

Note: 2 piece construction

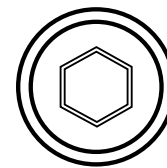
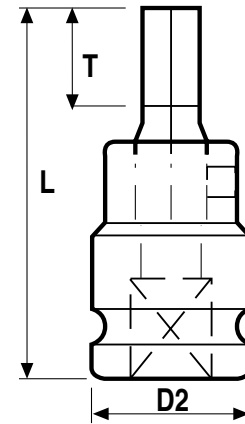

12 Point Impact Socket Sizes

SIZE in	SIZE mm	PART#	D1 mm	D2 mm	L mm	T mm	Weight gr
3/4	19	DH-0812M19	28	30	38	9.5	130
13/16		DH-0813	30	30	38	11	130
7/8		DH-0814	32	32	38	13	140
15/16		DH-0815	35	35	38	13	160
1		DH-0816	38	35	38	13	200
1-1/16	27	DH-0817M27	38	35	50	13	200
1-1/8		DH-0818	41	35	40	16.5	290
1 3/16	30	DH-0819M30	41	35	50	16.5	290
1-1/4		DH-0820	44	35	40	17	350
1-5/16		DH-0821	49	35	43	19	370
1-3/8	35	DH-0822M35	49	35	50	19	370
1-7/16		DH-0823	49	44	50	19	370
1-1/2	38	DH-0824M38	52	44	50	22	400

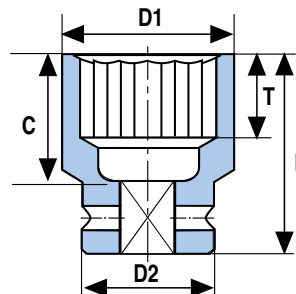

1/2" SQUARE DRIVE

ACCESSORIES

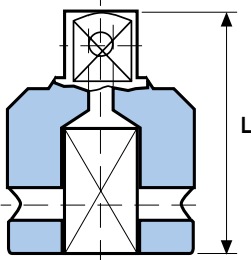

Adapters

PART#	FEMALE in	MALE in	L in
A0810	1/2	5/8	1.38
A0812	1/2	3/4	1.69

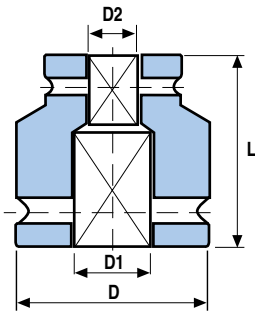

Double Ended Female Adapters

PART#	D1 in	D2 in	L in	D in
AN0808	1/2	1/2	1.29	.984
AN1008	5/8	1/2	1.61	1.38
AN1208	3/4	1/2	1.93	1.73



Universal Joint

SIZE in	PART#
1/2	U0808

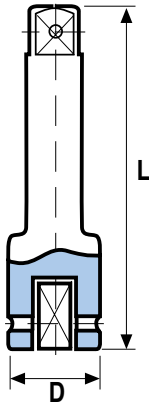

Extensions

PART#	D in	L in
E0803	1.181	3
E0805	1.181	5
E0810	1.181	10

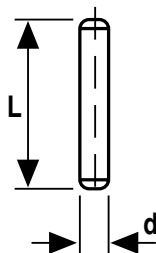
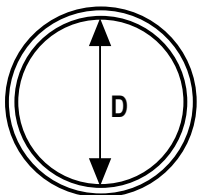

Retaining Pins and Rings

SQUARE DRIVE	SOCKET SIZES	PIN#	RING#	d in	L in	D in
1/2	Up To 9/16" (14mm)	P0825	R0825	.117	.780	.741
1/2	From 9/16" To 1-3/16" (30mm)	P0830	R0830	.117	.975	.936
1/2	Above 1-3/16" (30mm)	P0835	R0835	.117	1.17	1.17

1/2" SQUARE DRIVE

UTILITY SOCKETS

UTILITY SOCKETS (POWER LINE SOCKETS)

Z-081315S5 - 13/16" x 15/16"

Z-081618S5 - 1" X 1-1/8"

Specifically designed for hydraulic wrenches and impact wrenches

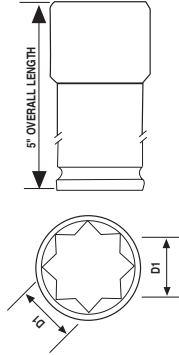

SQUARE DRIVE ADAPTER



Double Ended Male Adapters 7/16" Hex to 1/2" Square

PART#	D1 in	L in
S-084874	.881	3
S-084874-HD	.881	2.25



RETAINING RING®

Ret Rings are tool accessories used to attach impact sockets to the square drive anvil. The ret ring is a one piece design socket retainer with a steel insert encapsulated to reinforce a stress point between the socket and anvil.

Specific application part numbers have been provided for each socket type, starting with 3/4" drive.



5/8" SQUARE DRIVE

SIX POINT IMPACT SOCKETS

Why 5/8" drive? This unusual drive size was originally introduced in the 1930's to eliminate the "disappearing socket syndrome." It remains popular in several applications today for the heavier wall thickness than comparable 1/2" drive sockets.

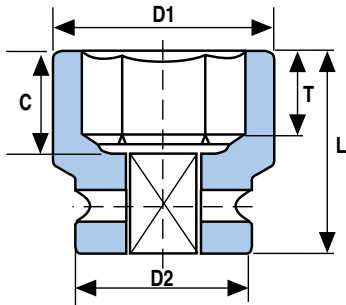

Standard Fractional Sizes

SIZE in	PART#	D1 in	D2 in	L in	T in	C in
1/2	Z-1008	.906	1.378	1.365	.236	.753
9/16	Z-1009	.945	1.378	1.365	.275	.753
5/8	Z-1010	1.024	1.378	1.365	.315	.753
11/16	Z-1011	1.142	1.378	1.482	.354	.871
3/4	Z-1012	1.220	1.378	1.482	.375	.871
13/16	Z-1013	1.299	1.378	1.482	.433	.871
7/8	Z-1014	1.378	1.378	1.560	.512	.950
15/16	Z-1015	1.378	1.378	1.560	.512	.950
1	Z-1016	1.496	1.378	1.600	.512	.989
1-1/16	Z-1017	1.614	1.378	1.600	.512	.989
1-1/8	Z-1018	1.614	1.378	1.638	.650	1.147
1-3/16	Z-1019	1.732	1.378	1.638	.650	1.147
1-1/4	Z-1020	1.732	1.378	1.794	.669	1.186
1-5/16	Z-1021	1.929	1.378	1.911	.748	1.265
1-3/8	Z-1022	1.929	1.378	1.989	.748	1.383
1-7/16	Z-1023	2.047	1.732	1.989	.748	1.383
1-1/2	Z-1024	2.126	1.732	1.989	.866	1.383

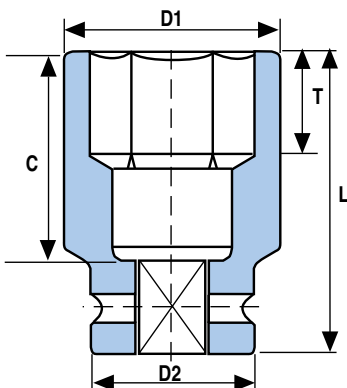

Deep Fractional Sizes

SIZE in	PART#	D1 in	D2 in	L in	T in	C in
1/2	Z-1008L	.906	1.378	3.465	.236	2.84
9/16	Z-1009L	.945	1.378	3.465	.275	2.84
5/8	Z-1010L	1.024	1.378	3.465	.315	2.84
11/16	Z-1011L	1.142	1.378	3.465	.354	2.84
3/4	Z-1012L	1.220	1.378	3.465	.375	2.84
13/16	Z-1013L	1.299	1.378	3.465	.433	2.84
7/8	Z-1014L	1.378	1.378	3.465	.512	2.84
15/16	Z-1015L	1.378	1.378	3.465	.512	2.84
1	Z-1016L	1.496	1.378	3.465	.512	2.84
1-1/16	Z-1017L	1.614	1.378	3.465	.512	2.84
1-1/8	Z-1018L	1.614	1.378	3.465	.650	2.84
1-3/16	Z-1019L	1.732	1.378	3.465	.650	2.84
1-1/4	Z-1020L	1.732	1.378	3.465	.669	2.84
1-5/16	Z-1021L	1.929	1.378	3.465	.748	2.84
1-3/8	Z-1022L	1.929	1.378	3.465	.748	2.84
1-7/16	Z-1023L	2.047	1.732	3.465	.748	2.84
1-1/2	Z-1024L	2.126	1.732	3.465	.866	2.84

5/8" SQUARE DRIVE

SIX POINT IMPACT SOCKETS

Standard Metric Sizes

SIZE mm	PART#	D1 mm	D2 mm	L mm	T mm	C mm
13	Z-10M13	23	35	35	6	19
14	Z-10M14	24	35	35	7	19
15	Z-10M15	26	35	35	7	19
16	Z-10M16	26	35	35	7	19
17	Z-10M17	28	35	38	9	22
18	Z-10M18	30	35	38	9	22
19	Z-10M19	31	35	38	9.5	22
20	Z-10M20	32	35	38	10	22
21	Z-10M21	33	35	38	10	22
22	Z-10M22	35	35	40	10	24
23	Z-10M23	35	35	40	12	24
24	Z-10M24	35	35	40	12	24
25	Z-10M25	38	35	41	13	25
26	Z-10M26	38	35	41	13	25
27	Z-10M27	41	35	42	13	25
28	Z-10M28	41	35	42	14	26
29	Z-10M29	41	35	45	14	29
30	Z-10M30	44	35	45	16.5	29
31	Z-10M31	44	35	46	16.5	42
32	Z-10M32	44	35	47	16.5	42
33	Z-10M33	44	35	47	17	31
34	Z-10M34	49	35	50	17	34
35	Z-10M35	49	35	51	19	35
36	Z-10M36	52	35	51	19	35
37	Z-10M37	54	44	51	19	35
38	Z-10M38	54	44	51	22	35

Deep Metric Sizes

SIZE mm	PART#	D1 mm	D2 mm	L mm	T mm	C mm
13	Z-10M13L	23	35	88	6	72
14	Z-10M14L	24	35	88	7	72
15	Z-10M15L	26	35	88	7	72
16	Z-10M16L	26	35	88	7	72
17	Z-10M17L	28	35	88	9	72
18	Z-10M18L	30	35	88	9	72
19	Z-10M19L	31	35	88	9.5	72
20	Z-10M20L	32	35	88	10	72
21	Z-10M21L	33	35	88	10	72
22	Z-10M22L	35	35	88	10	72
23	Z-10M23L	35	35	88	12	72
24	Z-10M24L	35	35	88	12	72
25	Z-10M25L	38	35	88	13	72
26	Z-10M26L	38	35	88	13	72
27	Z-10M27L	41	35	88	13	72
28	Z-10M28L	41	35	88	14	72
29	Z-10M29L	41	35	88	14	72
30	Z-10M30L	44	35	88	16.5	72
31	Z-10M31L	44	35	88	16.5	72
32	Z-10M32L	44	35	88	16.5	72
33	Z-10M33L	44	35	88	17	72
34	Z-10M34L	49	35	88	17	72
35	Z-10M35L	49	35	88	19	72
36	Z-10M36L	52	35	88	19	72
37	Z-10M37L	54	44	88	19	72
38	Z-10M38L	54	44	88	22	72

ACCESSORIES

Adapters

PART#	FEMALE in	MALE in	L in
A1008	5/8	1/2	1.90
A1012	5/8	3/4	1.77

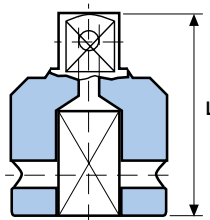

Universal Joint

SIZE in	PART#
5/8	U1010



Double Ended Female Adapters

PART#	D1 in	D2 in	L in	D in
AN1008	5/8	1/2	1.61	1.38
AN1010	5/8	5/8	1.38	1.38
AN1210	3/4	5/8	1.97	1.73

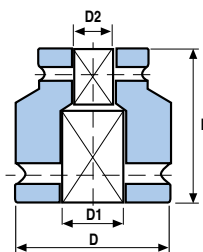

Double Ended Male Extensions

PART#	D in	L in
Z1002	0.830	2
Z1003	0.830	3
Z1006	0.830	6
Z1012	0.83	12

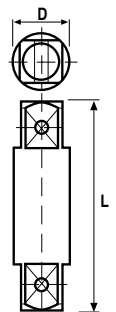

Retaining Pins and Rings

SQUARE DRIVE	SOCKET SIZES	PIN#	RING#	d in	L in	D in
5/8	Up To 1-3/16" (30mm)	P1035	R1035	.117	1.070	1.092
5/8	Above 1-3/16" (30mm)	P1044	R1044	.117	1.521	1.443

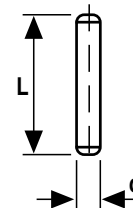
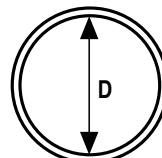

3/4" SQUARE DRIVE

SIX POINT IMPACT SOCKETS

OZAT 3/4" drive sockets (and larger) are also available by special order as Spark Resistant for use in mines, chemical plants, grain processors and anywhere explosive conditions exist.

Standard Fractional Sizes

SIZE in	PART#	D1 in	D2 in	L in	T in	C in	RET RING
1/2	Z-1208	.945	1.732	1.755	.236	.772	10032S
9/16	Z-1209	.984	1.732	1.755	.276	.772	10032S
5/8	Z-1210	1.102	1.732	1.755	.315	.772	10032S
11/16	Z-1211	1.142	1.732	1.755	.354	.772	10032S
3/4	Z-1212	1.260	1.732	1.755	.372	.772	10032S
13/16	Z-1213	1.378	1.732	1.794	.433	.890	10032S
7/8	Z-1214	1.496	1.732	1.794	.512	.890	10032S
15/16	Z-1215	1.575	1.732	1.794	.512	.890	10032S
1	Z-1216	1.614	1.732	1.794	.512	.890	10032S
1-1/16	Z-1217	1.732	1.732	2.028	.512	1.047	10032S
1-1/8	Z-1218	1.732	1.732	2.028	.650	1.047	10032S
1-3/16	Z-1219	1.732	1.732	2.028	.650	1.047	10032S
1-1/4	Z-1220	1.929	1.732	2.028	.650	1.047	10032S
1-5/16	Z-1221	1.929	1.732	2.145	.748	1.165	10032S
1-3/8	Z-1222	2.047	1.732	2.145	.748	1.165	10032S
1-7/16	Z-1223	2.047	1.732	2.184	.748	1.205	10032S
1-1/2	Z-1224	2.126	1.732	2.301	.866	1.283	10032S
1-9/16	Z-1225	2.244	1.732	2.301	.866	1.283	10032S
1-5/8	Z-1226	2.244	1.732	2.301	.866	1.283	10032S
1-11/16	Z-1227	2.480	1.732	2.496	.984	1.441	10032S
1-3/4	Z-1228	2.480	1.732	2.496	.995	1.480	10032S
1-13/16	Z-1229	2.638	1.732	2.496	.995	1.480	10032S
1-7/8	Z-1230	2.638	2.126	2.613	1.062	1.598	10010S
1-15/16	Z-1231	2.756	2.126	2.613	1.062	1.598	10010S
2	Z-1232	2.874	2.126	2.613	1.062	1.598	10010S
2-1/16	Z-1233	2.874	2.126	2.769	1.181	1.756	10010S
2-1/8	Z-1234	2.874	2.126	2.769	1.181	1.795	10010S
2-3/16	Z-1235	3.071	2.126	2.886	1.260	1.795	10010S
2-1/4	Z-1236	3.228	2.126	2.925	1.299	1.913	10010S
2-5/16	Z-1237	3.228	2.126	2.925	1.299	1.953	10010S
2-3/8	Z-1238	3.228	2.126	2.925	1.378	1.953	10010S

Deep Fractional Sizes

SIZE in	PART#	D1 in	D2 in	L in	T in	C in	RET RING
1/2	Z-1208L	.945	1.732	3.510	.236	2.543	10032S
9/16	Z-1209L	.984	1.732	3.510	.276	2.543	10032S
5/8	Z-1210L	1.102	1.732	3.510	.315	2.543	10032S
11/16	Z-1211L	1.142	1.732	3.510	.354	2.543	10032S
3/4	Z-1212L	1.260	1.732	3.510	.372	2.543	10032S
13/16	Z-1213L	1.378	1.732	3.510	.433	2.543	10032S
7/8	Z-1214L	1.496	1.732	3.510	.512	2.543	10032S
15/16	Z-1215L	1.575	1.732	3.510	.512	2.543	10032S
1	Z-1216L	1.614	1.732	3.510	.512	2.543	10032S
1-1/16	Z-1217L	1.732	1.732	3.510	.512	2.543	10032S
1-1/8	Z-1218L	1.732	1.732	3.510	.650	2.543	10032S
1-3/16	Z-1219L	1.732	1.732	3.510	.650	2.543	10032S
1-1/4	Z-1220L	1.929	1.732	3.510	.669	2.543	10032S
1-5/16	Z-1221L	1.929	1.732	3.510	.748	2.543	10032S
1-3/8	Z-1222L	2.047	1.732	3.510	.748	2.543	10032S
1-7/16	Z-1223L	2.047	1.732	3.510	.748	2.543	10032S
1-1/2	Z-1224L	2.126	1.732	3.510	.866	2.543	10032S
1-9/16	Z-1225L	2.244	1.732	3.510	.866	2.543	10032S
1-5/8	Z-1226L	2.244	1.732	3.510	.866	2.543	10032S
1-11/16	Z-1227L	2.480	1.732	3.510	.984	2.543	10032S
1-3/4	Z-1228L	2.480	1.732	3.510	.995	2.543	10032S
1-13/16	Z-1229L	2.638	1.732	3.510	.995	2.543	10032S
1-7/8	Z-1230L	2.638	2.126	3.510	1.062	2.543	10010S
1-15/16	Z-1231L	2.756	2.126	3.510	1.062	2.543	10010S
2	Z-1232L	2.874	2.126	3.510	1.062	2.543	10010S
2-1/16	Z-1233L	2.874	2.126	3.666	1.181	2.701	10010S
2-1/8	Z-1234L	2.874	2.126	3.666	1.181	2.740	10010S
2-3/16	Z-1235L	3.071	2.126	3.666	1.260	2.740	10010S
2-1/4	Z-1236L	3.228	2.126	3.822	1.299	2.858	10010S
2-5/16	Z-1237L	3.228	2.126	3.822	1.299	2.898	10010S
2-3/8	Z-1238L	3.228	2.126	3.822	1.378	2.898	10010S

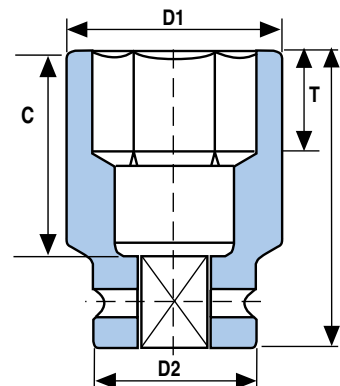
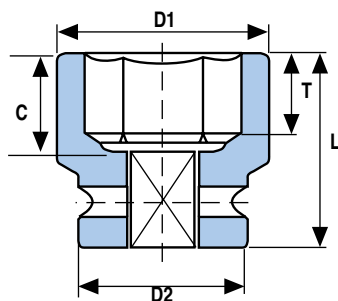

3/4" SQUARE DRIVE

SIX POINT IMPACT SOCKETS

Standard Metric Sizes

SIZE mm	PART#	D1 mm	D2 mm	L mm	T mm	C mm	RET RING
13	Z-12M13	25	44	45	6	20	10032S
14	Z-12M14	25	44	45	7	20	10032S
15	Z-12M15	28	44	45	7	20	10032S
16	Z-12M16	29	44	45	7	20	10032S
17	Z-12M17	29	44	45	9	20	10032S
18	Z-12M18	32	44	45	9.5	20	10032S
19	Z-12M19	32	44	45	9.5	20	10032S
20	Z-12M20	35	44	46	10	21	10032S
21	Z-12M21	35	44	46	10	21	10032S
22	Z-12M22	38	44	46	10	21	10032S
23	Z-12M23	38	44	46	12	21	10032S
24	Z-12M24	40	44	46	12	21	10032S
25	Z-12M25	41	44	46	13	21	10032S
26	Z-12M26	41	44	46	13	21	10032S
27	Z-12M27	41	44	48	13	23	10032S
28	Z-12M28	44	44	48	14	23	10032S
29	Z-12M29	44	44	52	14	27	10032S
30	Z-12M30	44	44	52	16.5	27	10032S
31	Z-12M31	49	44	52	16.5	27	10032S
32	Z-12M32	49	44	52	16.5	27	10032S
33	Z-12M33	49	44	55	17	30	10032S
34	Z-12M34	52	44	55	17	30	10032S
35	Z-12M35	52	44	55	19	30	10032S
36	Z-12M36	52	44	56	19	31	10032S
37	Z-12M37	54	44	56	19	31	10032S
38	Z-12M38	54	44	59	22	34	10032S
39	Z-12M39	57	44	59	21.5	34	10032S
40	Z-12M40	57	44	59	21.5	34	10032S
41	Z-12M41	57	44	59	22	34	10032S
42	Z-12M42	60	44	59	21.5	34	10032S
43	Z-12M43	63	44	64	25	39	10032S
44	Z-12M44	63	44	64	21.5	39	10032S
45	Z-12M45	63	44	64	21.5	39	10032S
46	Z-12M46	67	44	64	25.5	39	10032S
47	Z-12M47	67	54	64	23.5	39	10010S
48	Z-12M48	67	54	67	23.5	42	10010S
49	Z-12M49	70	54	67	27	42	10010S
50	Z-12M50	70	54	67	23.5	42	10010S
51	Z-12M51	73	54	67	27	42	10010S
52	Z-12M52	73	54	70	27	45	10010S
54	Z-12M54	78	54	71	30	46	10010S
55	Z-12M55	78	54	71	27	46	10010S
56	Z-12M56	78	54	74	28	49	10010S
57	Z-12M57	82	54	75	33	50	10010S
58	Z-12M58	82	54	75	28	50	10010S
59	Z-12M59	82	54	75	33	50	10010S
60	Z-12M60	82	54	75	28	50	10010S
61	Z-12M61	86	54	75	28	50	10010S

Deep Metric Sizes

SIZE mm	PART#	D1 mm	D2 mm	L mm	T mm	C mm	RET RING
13	Z-12M13L	25	44	90	6	65	10032S
14	Z-12M14L	25	44	90	7	65	10032S
15	Z-12M15L	28	44	90	7	65	10032S
16	Z-12M16L	29	44	90	7	65	10032S
17	Z-12M17L	29	44	90	9	65	10032S
18	Z-12M18L	32	44	90	9	65	10032S
19	Z-12M19L	32	44	90	9.5	65	10032S
20	Z-12M20L	35	44	90	10	65	10032S
21	Z-12M21L	35	44	90	10	65	10032S
22	Z-12M22L	38	44	90	10	65	10032S
23	Z-12M23L	38	44	90	12	65	10032S
24	Z-12M24L	40	44	90	12	65	10032S
25	Z-12M25L	41	44	90	13	65	10032S
26	Z-12M26L	41	44	90	13	65	10032S
27	Z-12M27L	41	44	90	13	65	10032S
28	Z-12M28L	44	44	90	14	65	10032S
29	Z-12M29L	44	44	90	14	65	10032S
30	Z-12M30L	44	44	90	16.5	65	10032S
31	Z-12M31L	49	44	90	16.5	65	10032S
32	Z-12M32L	49	44	90	16.5	65	10032S
33	Z-12M33L	49	44	90	17	65	10032S
34	Z-12M34L	52	44	90	17	65	10032S
35	Z-12M35L	52	44	90	19	65	10032S
36	Z-12M36L	52	44	90	19	65	10032S
37	Z-12M37L	54	44	90	19	65	10032S
38	Z-12M38L	54	44	90	22	65	10032S
39	Z-12M39L	57	44	90	21.5	65	10032S
40	Z-12M40L	57	44	90	21.5	65	10032S
41	Z-12M41L	57	44	90	22	65	10032S
42	Z-12M42L	60	44	90	21.5	65	10032S
43	Z-12M43L	63	44	90	25	65	10032S
44	Z-12M44L	63	44	90	21.5	65	10032S
45	Z-12M45L	63	44	90	21.5	65	10032S
46	Z-12M46L	67	44	90	25.5	65	10032S
47	Z-12M47L	67	54	90	23.5	65	10010S
48	Z-12M48L	67	54	90	23.5	65	10010S
49	Z-12M49L	70	54	90	27	65	10010S
50	Z-12M50L	70	54	90	23.5	65	10010S
51	Z-12M51L	73	54	94	27	65	10010S
52	Z-12M52L	73	54	94	27	65	10010S
54	Z-12M54L	78	54	94	30	69	10010S
55	Z-12M55L	78	54	94	27	69	10010S
56	Z-12M56L	78	54	98	28	69	10010S
57	Z-12M57L	82	54	98	33	73	10010S
58	Z-12M58L	82	54	98	28	73	10010S
59	Z-12M59L	82	54	98	33	73	10010S
60	Z-12M60L	82	54	98	28	73	10010S
61	Z-12M61L	86	54	98	28	73	10010S

Budd Wheel Socket Sizes

SIZE in	PART#	D1 in	D2 in	L in	T in	RET RING
13/16	Z-1213B	1.653	1.732	1.950	.433	10032S
13/16	Z-1213BL	1.653	1.732	3.510	.433	10032S
13/16 X 1-1/2	Z-1224BS	2.126	1.732	3.510	.571	10032S

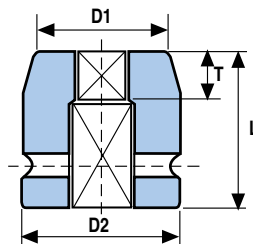

3/4" SQUARE DRIVE

SIX POINT IMPACT SOCKETS

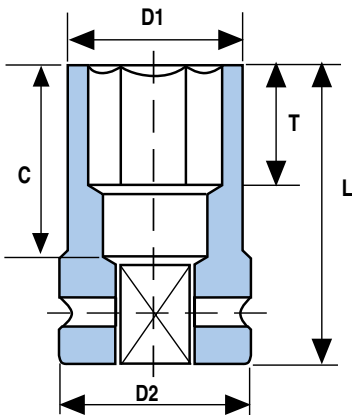

Standard Fractional Thinwall Sizes



SIZE in	PART#	D1 in	D2 in	L in	T in	C in	RET RING
11/16	Z-1211T	1.102	1.732	1.755	.354	.969	10032S
3/4	Z-1212T	1.181	1.732	1.755	.375	.969	10032S
13/16	Z-1213T	1.378	1.732	1.794	.433	.969	10032S
7/8	Z-1214T	1.378	1.732	1.794	.512	.969	10032S
15/16	Z-1215T	1.378	1.732	1.794	.512	.969	10032S
1	Z-1216T	1.496	1.732	1.794	.512	.969	10032S
1-1/16	Z-1217T	1.614	1.732	1.872	.512	1.047	10032S
1-1/8	Z-1218T	1.614	1.732	2.028	.650	1.047	10032S
1-3/16	Z-1219T	1.732	1.732	2.028	.650	1.047	10032S
1-1/4	Z-1220T	1.732	1.732	2.028	.669	1.047	10032S
1-5/16	Z-1221T	1.929	1.732	2.145	.748	1.165	10032S
1-3/8	Z-1222T	2.047	1.732	2.145	.748	1.165	10032S
1-7/16	Z-1223T	2.047	1.732	2.184	.748	1.205	10032S
1-1/2	Z-1224T	2.126	1.732	2.301	.866	1.283	10032S
1-9/16	Z-1225T	2.126	1.732	2.301	.866	1.283	10032S
1-5/8	Z-1226T	2.126	1.732	2.301	.866	1.283	10032S
1-11/16	Z-1227T	2.362	1.732	2.496	.984	1.441	10032S
1-3/4	Z-1228T	2.362	1.732	2.496	.995	1.480	10032S
1-13/16	Z-1229T	2.480	1.732	2.496	.995	1.480	10032S

Standard Metric Thinwall Sizes



SIZE in	PART#	D1 in	D2 in	L in	T in	C in	RET RING
17	Z-12M17T	28	44	45	9	20	10032S
18	Z-12M18T	30	44	45	9	20	10032S
19	Z-12M19T	30	44	45	9.5	21	10032S
20	Z-12M20T	30	44	46	10	21	10032S
21	Z-12M21T	35	44	46	10	21	10032S
22	Z-12M22T	35	44	46	10	21	10032S
23	Z-12M23T	35	44	46	12	21	10032S
24	Z-12M24T	38	44	46	12	21	10032S
25	Z-12M25T	38	44	46	13	21	10032S
26	Z-12M26T	41	44	46	13	21	10032S
27	Z-12M27T	41	44	48	13	23	10032S
28	Z-12M28T	41	44	48	14	23	10032S
29	Z-12M29T	41	44	52	14	27	10032S
30	Z-12M30T	41	44	52	16.5	27	10032S
31	Z-12M31T	44	44	52	16.5	27	10032S
32	Z-12M32T	48	44	52	16.5	27	10032S
33	Z-12M33T	48	44	55	17	30	10032S
34	Z-12M34T	49	44	55	17	30	10032S
35	Z-12M35T	50	44	55	19	30	10032S
36	Z-12M36T	52	44	56	19	31	10032S
37	Z-12M37T	52	44	56	19	31	10032S
38	Z-12M38T	52	44	59	22	34	10032S
39	Z-12M39T	54	44	59	21.5	34	10032S
40	Z-12M40T	54	44	59	21.5	34	10032S
41	Z-12M41T	54	44	59	22	34	10032S
42	Z-12M42T	57	44	59	21.5	34	10032S
43	Z-12M43T	60	44	64	25	39	10032S
44	Z-12M44T	60	44	64	21.5	39	10032S
45	Z-12M45T	60	44	64	21.5	39	10032S
46	Z-12M46T	63	44	64	25.5	39	10032S



3/4" SQUARE DRIVE

SIX POINT IMPACT SOCKETS

Deep Fractional Thinwall Sizes



SIZE in	PART#	D1 in	D2 in	L in	T in	C in	RET RING
11/16	Z-1211LT	1.102	1.732	3.510	0.709	2.543	10032S
3/4	Z-1212LT	1.181	1.732	3.510	0.748	2.543	10032S
13/16	Z-1213LT	1.378	1.732	3.510	0.866	2.543	10032S
7/8	Z-1214LT	1.378	1.732	3.510	1.024	2.543	10032S
15/16	Z-1215LT	1.378	1.732	3.510	1.024	2.543	10032S
1	Z-1216LT	1.496	1.732	3.510	1.024	2.543	10032S
1-1/16	Z-1217LT	1.614	1.732	3.510	1.024	2.543	10032S
1-1/8	Z-1218LT	1.614	1.732	3.510	1.299	2.543	10032S
1-3/16	Z-1219LT	1.732	1.732	3.510	1.299	2.543	10032S
1-1/4	Z-1220LT	1.732	1.732	3.510	1.339	2.543	10032S
1-5/16	Z-1221LT	1.929	1.732	3.510	1.496	2.543	10032S
1-3/8	Z-1222LT	2.047	1.732	3.510	1.496	2.543	10032S
1-7/16	Z-1223LT	2.047	1.732	3.510	1.496	2.543	10032S
1-1/2	Z-1224LT	2.126	1.732	3.510	1.732	2.543	10032S
1-9/16	Z-1225LT	2.126	1.732	3.510	1.732	2.543	10032S
1-5/8	Z-1226LT	2.126	1.732	3.510	1.732	2.543	10032S
1-11/16	Z-1227LT	2.362	1.732	3.510	1.969	2.543	10032S
1-3/4	Z-1228LT	2.362	1.732	3.510	2.008	2.543	10032S
1-13/16	Z-1229LT	2.480	1.732	3.510	2.008	2.543	10032S

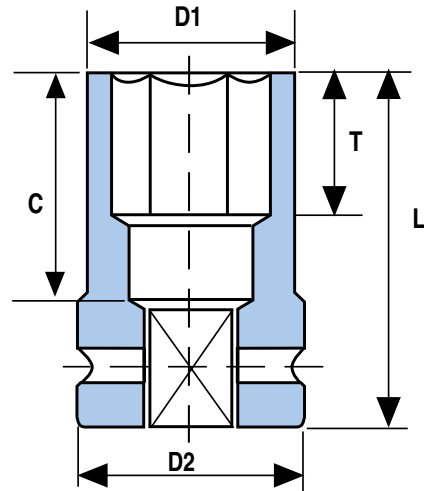

Deep Metric Thinwall Sizes



SIZE in	PART#	D1 in	D2 in	L in	T in	C in	RET RING
17	Z-12M17LT	28	44	90	18	65	10032S
18	Z-12M18LT	30	44	90	18	65	10032S
19	Z-12M19LT	30	44	90	19	65	10032S
20	Z-12M20LT	30	44	90	20	65	10032S
21	Z-12M21LT	35	44	90	20	65	10032S
22	Z-12M22LT	35	44	90	20	65	10032S
23	Z-12M23LT	35	44	90	24	65	10032S
24	Z-12M24LT	38	44	90	24	65	10032S
25	Z-12M25LT	38	44	90	26	65	10032S
26	Z-12M26LT	41	44	90	26	65	10032S
27	Z-12M27LT	41	44	90	26	65	10032S
28	Z-12M28LT	41	44	90	28	65	10032S
29	Z-12M29LT	41	44	90	28	65	10032S
30	Z-12M30LT	41	44	90	33	65	10032S
31	Z-12M31LT	44	44	90	33	65	10032S
32	Z-12M32LT	48	44	90	33	65	10032S
33	Z-12M33LT	48	44	90	34	65	10032S
34	Z-12M34LT	49	44	90	34	65	10032S
35	Z-12M35LT	50	44	90	38	65	10032S
36	Z-12M36LT	52	44	90	38	65	10032S
37	Z-12M37LT	52	44	90	38	65	10032S
38	Z-12M38LT	52	44	90	44	65	10032S
39	Z-12M39LT	54	44	90	43	65	10032S
40	Z-12M40LT	54	44	90	43	65	10032S
41	Z-12M41LT	54	44	90	44	65	10032S
42	Z-12M42LT	57	44	90	43	65	10032S
43	Z-12M43LT	60	44	90	50	65	10032S
44	Z-12M44LT	60	44	90	43	65	10032S
45	Z-12M45LT	60	44	90	43	65	10032S
46	Z-12M46LT	63	44	90	51	65	10032S



3/4" SQUARE DRIVE

HEX DRIVER SOCKETS

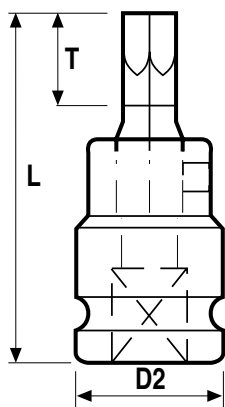

Fractional Sizes

SIZE in	PART#	D2 in	L in	T in	RET RING
3/8	Z-1206H	1.496	2.637	1.130	10005S
7/16	Z-1207H	1.496	2.637	1.13	10005S
1/2	Z-1208H	1.496	2.637	1.130	10005S
9/16	Z-1209H	1.496	2.637	1.130	10005S
5/8	Z-1210H	1.496	2.637	1.130	10005S
3/4	Z-1212H	1.732	2.637	1.130	10032S
13/16	Z-1213H	1.732	2.795	1.295	10032S
7/8	Z-1214H	1.732	2.795	1.295	10032S
1	Z-1216H	1.732	2.795	1.295	10032S

Note: 1 piece construction

Metric Sizes

SIZE mm	PART#	D2 mm	L mm	T mm	RET RING
10	Z-12M10H	38	67	29	10005S
12	Z-12M12H	38	67	29	10005S
14	Z-12M14H	38	67	29	10005S
17	Z-12M17H	38	67	29	10005S
19	Z-12M19H	44	67	29	10032S
22	Z-12M22H	44	71	33	10032S
24	Z-12M24H	44	71	33	10032S

Note: 1 piece construction

2-Part In-Hex Sizes

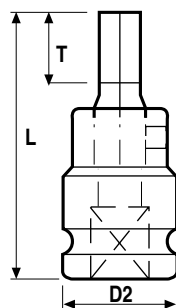

HEX in	HEX mm	PART#	D2 mm	L mm	T mm	Weight gr	RET RING	REPLACEMENT HEX BIT
3/8		Z-1206V	38	69	16	310	10005S	H06
7/16		Z-1207V	38	69	18	310	10005S	H07
1/2		Z-1208V	38	69	19	310	10005S	H08
9/16		Z-1209V	38	69	21	310	10005S	H09
5/8		Z-1210V	38	69	24	310	10005S	H10
3/4		Z-1212V	44	69	26	630	10032S	H12
13/16		Z-1213V	44	84	26	630	10032S	H13
7/8		Z-1214V	44	84	26	630	10032S	H14
1		Z-1216V	44	104	30	630	10032S	H16
	10	Z-12M10V	38	69	16	310	10005S	HM10
	12	Z-12M12V	38	69	18	310	10005S	HM12
	14	Z-12M14V	38	69	21	310	10005S	HM14
	17	Z-12M17V	38	69	26	310	10005S	HM17
	19	Z-12M19V	44	84	26	630	10032S	HM19
	22	Z-12M22V	44	84	26	630	10032S	HM22
	24	Z-12M24V	44	84	26	630	10032S	HM24

Note: 2 piece construction



DOUBLE SQUARE EIGHT POINT IMPACT SOCKETS

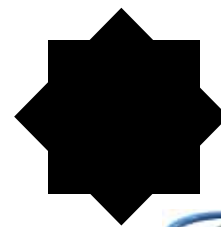

Standard Fractional Sizes

SIZE in	PART#	D1 in	D2 in	L in	T in	C in	RET RING
1-1/4	DS-1220	2.362	1.732	2.067	.669	1.087	10032S
1-5/16	DS-1221	2.480	1.732	2.067	.748	1.087	10032S
1-3/8	DS-1222	2.638	1.732	2.067	.748	1.087	10032S
1-7/16	DS-1223	2.638	1.732	2.223	.748	1.244	10032S
1-1/2	DS-1224	2.638	1.732	2.223	.866	1.244	10032S
1-9/16	DS-1225	3.071	2.126	2.223	.866	1.244	10010S
1-5/8	DS-1226	3.071	2.126	2.223	.866	1.244	10010S
1-11/16	DS-1227	3.228	2.126	2.418	.984	1.441	10010S
1-3/4	DS-1228	3.228	2.126	2.457	1.005	1.480	10010S
1-13/16	DS-1229	3.228	2.126	2.457	1.005	1.480	10010S
1-7/8	DS-1230	3.228	2.126	2.535	1.063	1.559	10010S

Deep Fractional Sizes

SIZE in	PART#	D1 in	D2 in	L in	T in	C in	RET RING
1-1/4	DS-1220L	2.362	1.732	3.159	.669	2.189	10032S
1-5/16	DS-1221L	2.480	1.732	3.159	.748	2.189	10032S
1-3/8	DS-1222L	2.638	1.732	3.159	.748	2.189	10032S
1-7/16	DS-1223L	2.638	1.732	3.159	.748	2.189	10032S
1-1/2	DS-1224L	2.638	1.732	3.159	.866	2.189	10032S
1-9/16	DS-1225L	3.071	2.126	3.159	.866	2.189	10010S
1-5/8	DS-1226L	3.071	2.126	3.159	.866	2.189	10010S
1-11/16	DS-1227L	3.228	2.126	3.159	.984	2.189	10010S
1-3/4	DS-1228L	3.228	2.126	3.159	1.005	2.189	10010S
1-13/16	DS-1229L	3.228	2.126	3.159	1.005	2.189	10010S
1-7/8	DS-1230L	3.228	2.126	3.159	1.063	2.189	10010S

3/4" SQUARE DRIVE

12 POINT IMPACT SOCKETS

12 Point Impact Socket Sizes



SIZE in	SIZE mm	PART#	D1 mm	D2 mm	L mm	T mm	Weight gr	RET RING
3/4	19	DH-1212M19	32	44	45	9.5	290	10032S
15/16		DH-1215	40	44	46	13.0	340	10032S
1		DH-1216	41	44	46	13.0	340	10032S
1-1/16	27	DH-1217M27	41	44	48	13.0	340	10032S
1-1/8		DH-1218	44	44	52	16.5	380	10032S
1-3/16	30	DH-1219M30	44	44	52	16.5	380	10032S
1-1/4		DH-1220	49	44	52	17.0	420	10032S
1-5/16		DH-1221	49	44	55	19.0	430	10032S
	33	DH-12M33	49	44	55	17.0	430	10032S
	34	DH-12M34	52	44	55	19.0	460	10032S
1-3/8	35	DH-1222M35	52	44	55	19.0	460	10032S
	36	DH-12M36	52	44	55	19.0	460	10032S
1-7/16		DH-1223	52	44	56	19.0	460	10032S
	37	DH-12M37	54	44	56	19.0	490	10032S
1-1/2	38	DH-1224M38	54	44	59	22.0	490	10032S
	39	DH-12M39	57	44	59	22.0	520	10032S
1-9/16		DH-1225	57	44	59	22.0	520	10032S
	40	DH-12M40	57	44	59	22.0	520	10032S
1-5/8	41	DH-1226M41	57	44	59	22.0	520	10032S
	42	DH-12M42	60	44	59	22.0	520	10032S
1-11/16	43	DH-1227M43	63	44	64	25.0	600	10032S
	44	DH-12M44	63	44	64	25.0	600	10032S
1-3/4		DH-1228	63	44	64	25.0	600	10032S
	45	DH-12M45	63	44	64	25.0	600	10032S
1-13/16	46	DH-1229M46	67	44	64	25.0	850	10032S
	47	DH-12M47	67	54	64	25.0	850	10010S
1-7/8		DH-1230	67	54	67	27.0	910	10010S
	48	DH-12M48	67	54	67	27.0	910	10010S
1-15/16	49	DH-1231M49	70	54	67	27.0	950	10010S
	50	DH-12M50	70	54	67	27.0	950	10010S
2	51	DH-1232M51	73	54	67	27.0	1040	10010S
	52	DH-12M52	73	54	70	27.0	1040	10010S
2-1/16		DH-1233	73	54	71	30.0	1040	10010S
2-1/8	54	DH-1234M54	73	54	71	30.0	1040	10010S
	55	DH-12M55	78	54	71	30.0	1200	10010S
2-3/16		DH-1235	78	54	74	32.0	1200	10010S
	56	DH-12M56	78	54	74	32.0	1200	10010S
2-1/4	57	DH-1236M57	82	54	75	33.0	1320	10010S
	58	DH-12M58	82	54	75	33.0	1320	10010S
2-5/16	59	DH-1237M59	82	54	75	33.0	1320	10010S
	60	DH-12M60	82	54	75	33.0	1320	10010S
2-3/8		DH-1238	82	54	75	35.0	1320	10010S
	61	DH-12M61	86	54	75	35.0	1430	10010S

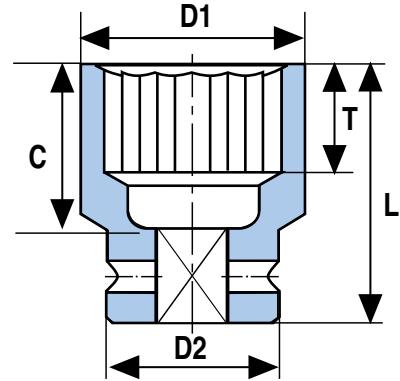

3/4" SQUARE DRIVE

ACCESSORIES



Universal Joint



SIZE in	PART#	RET RING
3/4	U1212	10032S

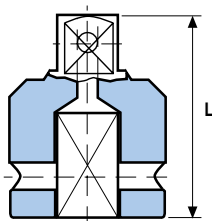

Adapters



PART#	FEMALE in	MALE in	L in	RET RING
A1208	3/4	1/2	2.165	10032S
A1210	3/4	5/8	2.244	10032S
A1216	3/4	1	2.322	10032S

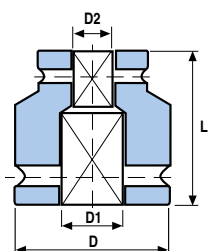

Double Ended Female Adapters



PART#	D1 in	D2 in	L in	D in	RET RINGS (D1) (D2)
AN1208	3/4	1/2	1.93	1.73	10032S 10005S
AN1210	3/4	5/8	1.97	1.73	10032S 10005S
AN1212	3/4	3/4	1.93	1.73	10032S 10032S
AN1612	1	3/4	2.48	2.13	10008S 10032S

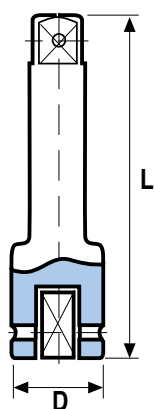

Extensions



PART#	D in	L in	RET RING
E1203	1.732	3	10032S
E1204	1.732	4	10032S
E1205	1.732	5	10032S
E1207	1.732	7	10032S
E1213	1.732	13	10032S

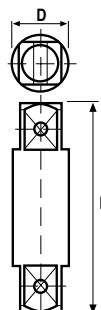

Double Ended Male Extensions

PART#	D in	L in
Z1202	1	2
Z1203	1	3
Z1204	1	4
Z1205	1	5
Z1207	1	7
Z1210	1	10
Z1213	1	13
Z1215	1	15
Z1216	1	16

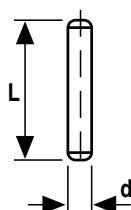
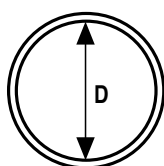

Retaining Pins and Rings

SQUARE DRIVE	SOCKET SIZES	PIN#	RING#	d in	L in	D in
3/4	Up To 1-13/16" (46mm)	P1244	R1244	.156	1.365	1.404
3/4	Above 1-13/16" (46mm)	P1254	R1254	.156	1.750	1.794

RAILROAD SOCKETS

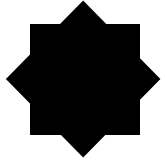

3/4" SQUARE DRIVE: DOUBLE SQUARE EIGHT POINT IMPACT SOCKETS



Standard Fractional Sizes

SIZE in	PART#	D1 in	D2 in	L in	T in	C in	RET RING
1-1/4	DS-1220	2.362	1.732	2.067	.669	1.087	10032S
1-5/16	DS-1221	2.480	1.732	2.067	.748	1.087	10032S
1-3/8	DS-1222	2.638	1.732	2.067	.748	1.087	10032S
1-7/16	DS-1223	2.638	1.732	2.223	.748	1.244	10032S
1-1/2	DS-1224	2.638	1.732	2.223	.866	1.244	10032S
1-9/16	DS-1225	3.071	2.126	2.223	.866	1.244	10010S
1-5/8	DS-1226	3.071	2.126	2.223	.866	1.244	10010S
1-11/16	DS-1227	3.228	2.126	2.418	.984	1.441	10010S
1-3/4	DS-1228	3.228	2.126	2.457	1.005	1.480	10010S
1-13/16	DS-1229	3.228	2.126	2.457	1.005	1.480	10010S
1-7/8	DS-1230	3.228	2.126	2.535	1.063	1.559	10010S

Deep Fractional Sizes

SIZE in	PART#	D1 in	D2 in	L in	T in	C in	RET RING
1-1/4	DS-1220L	2.362	1.732	3.159	.669	2.189	10032S
1-5/16	DS-1221L	2.480	1.732	3.159	.748	2.189	10032S
1-3/8	DS-1222L	2.638	1.732	3.159	.748	2.189	10032S
1-7/16	DS-1223L	2.638	1.732	3.159	.748	2.189	10032S
1-1/2	DS-1224L	2.638	1.732	3.159	.866	2.189	10032S
1-9/16	DS-1225L	3.071	2.126	3.159	.866	2.189	10010S
1-5/8	DS-1226L	3.071	2.126	3.159	.866	2.189	10010S
1-11/16	DS-1227L	3.228	2.126	3.159	.984	2.189	10010S
1-3/4	DS-1228L	3.228	2.126	3.159	1.005	2.189	10010S
1-13/16	DS-1229L	3.228	2.126	3.159	1.005	2.189	10010S
1-7/8	DS-1230L	3.228	2.126	3.159	1.063	2.189	10010S

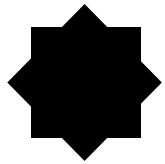

1" SQUARE DRIVE: DOUBLE SQUARE EIGHT POINT IMPACT SOCKETS



Standard Fractional Sizes

SIZE in	PART#	D1 in	D2 in	L in	T in	C in	RET RING
1-5/16	DS-1621	2.480	2.126	2.262	.748	1.283	10010S
1-3/8	DS-1622	2.638	2.362	2.262	.748	1.283	10015S
1-7/16	DS-1623	2.638	2.362	2.262	.748	1.283	10015S
1-1/2	DS-1624	2.756	2.362	2.418	.866	1.441	10015S
1-9/16	DS-1625	3.071	2.362	2.418	.866	1.441	10015S
1-5/8	DS-1626	3.071	2.362	2.418	.866	1.441	10015S
1-11/16	DS-1627	3.228	2.362	2.613	.984	1.638	10015S
1-3/4	DS-1628	3.228	2.362	2.613	1.005	1.638	10015S
1-13/16	DS-1629	3.386	2.362	2.613	1.005	1.638	10015S
1-7/8	DS-1630	3.386	2.362	2.730	1.063	1.756	10015S
2	DS-1632	3.622	2.362	2.730	1.063	1.756	10015S
2-1/8	DS-1634	3.937	2.362	2.925	1.181	1.953	10015S
2-3/16	DS-1635	3.937	2.362	3.042	1.260	2.071	10015S
2-1/4	DS-1636	3.937	2.362	3.042	1.260	2.071	10015S
2-3/8	DS-1638	4.134	2.362	3.198	1.378	2.228	10015S
2-1/2	DS-1640	4.291	2.362	3.432	1.378	2.465	10015S

Note: Metric Sizes 35, 38, 41, 46, 51, 54, 57 are also available by special order. (POR)

Deep Fractional Sizes

SIZE in	PART#	D1 in	D2 in	L in	T in	C in	RET RING
1-5/16	DS-1621L	2.480	2.126	3.159	.748	2.189	10010S
1-3/8	DS-1622L	2.638	2.362	3.159	.748	2.189	10015S
1-7/16	DS-1623L	2.638	2.362	3.159	.748	2.189	10015S
1-1/2	DS-1624L	2.756	2.362	3.393	.866	2.322	10015S
1-9/16	DS-1625L	3.071	2.362	3.432	.866	2.322	10015S
1-5/8	DS-1626L	3.071	2.362	3.432	.866	2.322	10015S
1-11/16	DS-1627L	3.228	2.362	3.432	.984	2.322	10015S
1-3/4	DS-1628L	3.228	2.362	3.432	1.005	2.322	10015S
1-13/16	DS-1629L	3.386	2.362	3.432	1.005	2.322	10015S
1-7/8	DS-1630L	3.386	2.362	3.432	1.063	2.322	10015S
2	DS-1632L	3.622	2.362	3.432	1.063	2.322	10015S
2-1/8	DS-1634L	3.937	2.362	3.783	1.181	2.819	10015S
2-3/16	DS-1635L	3.937	2.362	3.783	1.260	2.819	10015S
2-1/4	DS-1636L	3.937	2.362	3.900	1.260	2.937	10015S
2-3/8	DS-1638L	4.134	2.362	3.900	1.378	2.937	10015S
2-1/2	DS-1640L	4.291	2.362	3.900	1.378	2.937	10015S

Note: Metric Sizes 35, 38, 41, 46, 51, 54, 57 are also available by special order. (POR)

SPECIAL RAILROAD SOCKETS

PART#	DESCRIPTION	RET RING
Z-161418RTL	7/8 X 1-1/8 Rectangle X 1 sq.	10008S
Z-16T70	70mm X 1 sq. Torx Bit Socket	10008S
N7167A	Domed Head Socket w/ Pins, 1" sq. drive	10015S

Railroad Sockets are also available in square 4 point and rectangular 4 point tapered to fit Lag Screws by special order. (POR)

Part#	Description	Size	Length
AN2424	Double ended female adaptor	1-1/2" x 1-1/2" sq.	3.35"
Z2410	Double ended male adaptor	1-1/2" x 1-1/2" sq.	10"

Part#	Female	Male Taper	Length
HEX-3	1-1/2" sq.	3/4" sq. to 1-7/8" sq	10"
HEX-3-10	1-1/2" sq.	3/4" sq. to 17/8" sq.	20"
HEX-12	2-1/2" sq.	3/4" sq. to 1-7/8" sq	12"

1" SQUARE DRIVE

SIX POINT IMPACT SOCKETS

ATP maintains "in stock" one of the broadest ranges of 1" drive sockets available to industry. OZAT 1" drive sizes are equally well suited for construction, maintenance, and heavy assembly applications, as well as for precision bolting with hydraulic bolting equipment.

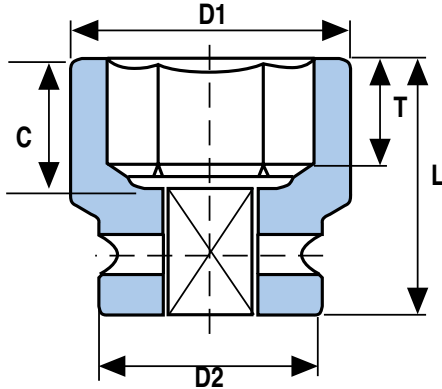

Standard Fractional Sizes

SIZE in	PART#	D1 in	D2 in	L in	T in	C in	RET RING
3/4	Z-1612	1.417	2.126	2.145	.374	1.040	10010S
13/16	Z-1613	1.496	2.126	2.145	.433	1.040	10010S
7/8	Z-1614	1.575	2.126	2.145	.551	1.040	10010S
15/16	Z-1615	1.614	2.126	2.145	.551	1.040	10010S
1	Z-1616	1.693	2.126	2.145	.551	1.119	10010S
1-1/16	Z-1617	1.811	2.126	2.145	.551	1.119	10010S
1-1/8	Z-1618	1.890	2.126	2.223	.650	1.119	10010S
1-3/16	Z-1619	1.969	2.126	2.223	.650	1.119	10010S
1-1/4	Z-1620	2.008	2.126	2.223	.669	1.119	10010S
1-5/16	Z-1621	2.126	2.126	2.340	.748	1.198	10010S
1-3/8	Z-1622	2.126	2.126	2.340	.748	1.198	10010S
1-7/16	Z-1623	2.126	2.126	2.340	.748	1.198	10010S
1-1/2	Z-1624	2.362	2.126	2.496	.866	1.316	10010S
1-9/16	Z-1625	2.362	2.126	2.496	.866	1.316	10010S
1-5/8	Z-1626	2.480	2.126	2.496	.866	1.316	10010S
1-11/16	Z-1627	2.638	2.126	2.691	.984	1.513	10010S
1-3/4	Z-1628	2.756	2.126	2.691	1.004	1.592	10010S
1-13/16	Z-1629	2.756	2.126	2.691	1.004	1.592	10010S
1-7/8	Z-1630	2.756	2.126	2.808	1.062	1.631	10010S
1-15/16	Z-1631	2.874	2.126	2.808	1.062	1.631	10010S
2	Z-1632	2.874	2.126	2.808	1.062	1.631	10010S
2-1/16	Z-1633	3.071	2.126	2.964	1.181	1.828	10010S
2-1/8	Z-1634	3.228	2.126	2.964	1.181	1.828	10010S
2-3/16	Z-1635	3.228	2.126	3.120	1.259	1.946	10010S
2-1/4	Z-1636	3.228	2.126	3.120	1.299	1.946	10010S
2-5/16	Z-1637	3.386	2.126	3.198	1.299	2.025	10010S
2-3/8	Z-1638	3.386	2.126	3.315	1.378	2.418	10010S
2-7/16	Z-1639	3.622	2.126	3.315	1.378	2.418	10010S
2-1/2	Z-1640	3.622	2.126	3.315	1.378	2.418	10010S
2-9/16	Z-1641	3.622	2.126	3.315	1.378	2.458	10010S
2-5/8	Z-1642	3.622	2.126	3.432	1.496	2.536	10010S
2-11/16	Z-1643	3.780	2.126	3.432	1.496	2.576	10010S
2-3/4	Z-1644	3.780	2.126	3.432	1.496	2.615	10010S
2-13/16	Z-1645	3.937	3.386	3.588	1.575	2.615	10021S
2-7/8	Z-1646	3.937	3.386	3.588	1.614	2.615	10021S
2-15/16	Z-1647	3.937	3.386	3.588	1.614	2.615	10021S
3	Z-1648	4.134	3.386	3.783	1.732	2.655	10021S
3-1/16	Z-1649	4.134	3.386	3.783	1.732	2.655	10021S
3-1/8	Z-1650	4.134	3.386	3.783	1.732	2.655	10021S
3-3/16	Z-1651	4.291	3.386	3.900	1.850	2.812	10021S
3-1/4	Z-1652	4.291	3.386	3.900	1.850	2.812	10021S
3-5/16	Z-1653	4.291	3.386	3.900	1.850	2.812	10021S
3-3/8	Z-1654	4.291	3.386	4.056	1.929	2.930	10021S
3-7/16	Z-1655	4.764	3.386	4.056	1.929	2.930	10021S
3-1/2	Z-1656	4.764	3.386	4.056	1.929	2.930	10021S
3-9/16	Z-1657	5.000	3.386	4.056	1.890	2.930	10021S
3-5/8	Z-1658	5.118	3.386	4.056	1.929	2.930	10021S
3-11/16	Z-1659	5.118	3.386	4.056	1.929	2.930	10021S
3-3/4	Z-1660	5.315	3.386	4.134	1.929	3.245	10021S
3-13/16	Z-1661	5.315	3.386	4.368	2.125	3.245	10021S
3-7/8	Z-1662	5.315	3.386	4.368	2.125	3.245	10021S
3-15/16	Z-1663	5.315	3.386	4.368	2.125	3.245	10021S
4	Z-1664	5.512	5.000	4.368	2.125	3.245	*
4-1/16	Z-1665	4.512	5.000	4.368	2.125	3.245	*
4-1/8	Z-1666	5.709	5.000	4.368	2.125	3.245	*
4-3/16	Z-1667	5.709	5.000	4.758	2.441	3.245	*
4-1/4	Z-1668	5.709	5.000	4.758	2.441	3.599	*
4-5/16	Z-1669	5.906	5.000	4.758	2.441	3.599	*
4-3/8	Z-1670	5.906	5.000	4.758	2.441	3.599	*
4-7/16	Z-1671	6.102	5.000	4.758	2.441	3.599	*
4-1/2	Z-1672	6.102	5.000	4.758	2.441	3.599	*

* Requires retaining pin and ring, Pin = P16127, Ring = R16127

1" SQUARE DRIVE

SIX POINT IMPACT SOCKETS

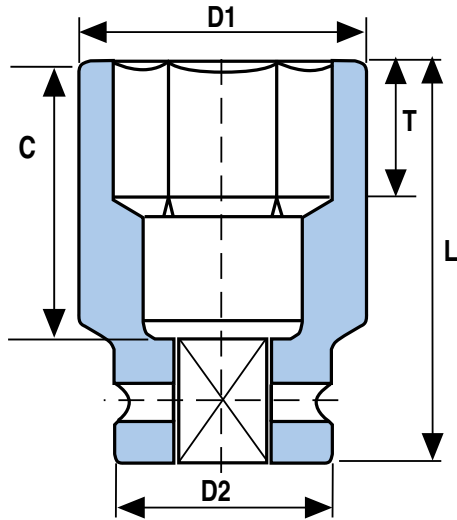

Deep Fractional Sizes



SIZE in	PART#	D1 in	D2 in	L in	T in	C in	RET RING
3/4	Z-1612L	1.417	2.126	3.900	0.374	2.812	10010S
13/16	Z-1613L	1.496	2.126	3.900	0.433	2.812	10010S
7/8	Z-1614L	1.575	2.126	3.900	0.551	2.812	10010S
15/16	Z-1615L	1.614	2.126	3.900	0.551	2.812	10010S
1	Z-1616L	1.693	2.126	3.900	0.551	2.812	10010S
1-1/16	Z-1617L	1.811	2.126	3.900	0.551	2.812	10010S
1-1/8	Z-1618L	1.890	2.126	3.900	0.650	2.812	10010S
1-3/16	Z-1619L	1.969	2.126	3.900	0.650	2.812	10010S
1-1/4	Z-1620L	2.008	2.126	3.900	0.669	2.812	10010S
1-5/16	Z-1621L	2.126	2.126	3.900	0.748	2.812	10010S
1-3/8	Z-1622L	2.126	2.126	3.900	0.748	2.812	10010S
1-7/16	Z-1623L	2.126	2.126	3.900	0.748	2.812	10010S
1-1/2	Z-1624L	2.362	2.126	3.900	0.866	2.812	10010S
1-9/16	Z-1625L	2.362	2.126	3.900	0.866	2.812	10010S
1-5/8	Z-1626L	2.480	2.126	3.900	0.866	2.812	10010S
1-11/16	Z-1627L	2.638	2.126	3.900	0.984	2.812	10010S
1-3/4	Z-1628L	2.756	2.126	3.900	1.004	2.812	10010S
1-13/16	Z-1629L	2.756	2.126	3.900	1.004	2.812	10010S
1-7/8	Z-1630L	2.756	2.126	3.900	1.062	2.812	10010S
1-15/16	Z-1631L	2.874	2.126	3.900	1.062	2.812	10010S
2	Z-1632L	2.874	2.126	3.900	1.062	2.812	10010S
2-1/16	Z-1633L	3.071	2.126	3.900	1.181	2.969	10010S
2-1/8	Z-1634L	3.228	2.126	4.056	1.181	2.969	10010S
2-3/16	Z-1635L	3.228	2.126	4.095	1.259	3.088	10010S
2-1/4	Z-1636L	3.228	2.126	4.095	1.299	3.088	10010S
2-5/16	Z-1637L	3.386	2.126	4.368	1.299	3.166	10010S
2-3/8	Z-1638L	3.386	2.126	4.368	1.378	3.560	10010S
2-7/16	Z-1639L	3.622	2.126	4.602	1.378	3.560	10010S
2-1/2	Z-1640L	3.622	2.126	4.602	1.378	3.560	10010S
2-9/16	Z-1641L	3.622	2.126	4.602	1.378	3.599	10010S
2-5/8	Z-1642L	3.622	2.126	4.602	1.496	3.678	10010S
2-11/16	Z-1643L	3.780	2.126	4.836	1.496	3.718	10010S
2-3/4	Z-1644L	3.780	2.126	4.836	1.496	3.757	10010S
2-13/16	Z-1645L	3.937	3.386	4.836	1.575	3.757	10021S
2-7/8	Z-1646L	3.937	3.386	4.836	1.614	3.757	10021S
2-15/16	Z-1647L	3.937	3.386	4.836	1.614	3.757	10021S
3	Z-1648L	4.134	3.386	5.07	1.732	3.796	10021S
3-1/16	Z-1649L	4.134	3.386	5.07	1.732	3.796	10021S
3-1/8	Z-1650L	4.134	3.386	5.148	1.732	3.796	10021S
3-3/16	Z-1651L	4.291	3.386	5.148	1.850	3.954	10021S
3-1/4	Z-1652L	4.291	3.386	5.148	1.850	3.954	10021S
3-5/16	Z-1653L	4.291	3.386	5.148	1.850	3.954	10021S
3-3/8	Z-1654L	4.291	3.386	5.460	1.929	4.072	10021S
3-7/16	Z-1655L	4.764	3.386	5.460	1.929	4.072	10021S
3-1/2	Z-1656L	4.764	3.386	5.460	1.929	4.072	10021S
3-9/16	Z-1657L	5.000	3.386	5.460	1.890	4.072	10021S
3-5/8	Z-1658L	5.118	3.386	5.460	1.929	4.072	10021S
3-11/16	Z-1659L	5.118	3.386	5.460	1.929	4.072	10021S
3-3/4	Z-1660L	5.315	3.386	5.460	1.929	4.387	10021S
3-13/16	Z-1661L	5.315	3.386	5.577	2.125	4.387	10021S
3-7/8	Z-1662L	5.315	3.386	5.577	2.125	4.387	10021S
3-15/16	Z-1663L	5.315	3.386	5.577	2.125	4.387	10021S
4	Z-1664L	5.512	5.000	5.577	2.125	4.387	*
4-1/16	Z-1665L	4.512	5.000	5.577	2.125	4.387	*
4-1/8	Z-1666L	5.709	5.000	5.577	2.125	4.387	*
4-3/16	Z-1667L	5.709	5.000	5.811	2.441	4.387	*
4-1/4	Z-1668L	5.709	5.000	5.811	2.441	4.741	*
4-5/16	Z-1669L	5.906	5.000	5.811	2.441	4.741	*
4-3/8	Z-1670L	5.906	5.000	5.811	2.441	4.741	*
4-7/16	Z-1671L	6.102	5.000	5.811	2.441	4.741	*
4-1/2	Z-1672L	6.102	5.000	5.811	2.441	4.741	*

* Requires retaining pin and ring, Pin = P16127, Ring = R16127

1" SQUARE DRIVE

SIX POINT IMPACT SOCKETS

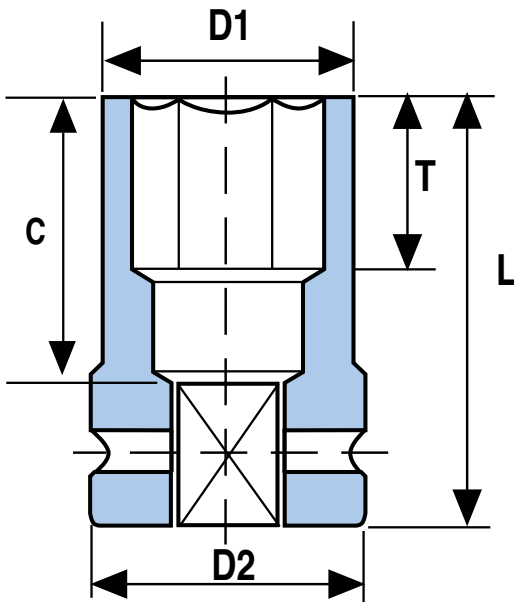

Deep Fractional Thinwall Sizes

SIZE in	PART#	D1 in	D2 in	L in	T in	C in	RET RING
7/8	Z-1614LT	1.496	2.126	3.937	.500	2.812	10010S
15/16	Z-1615LT	1.496	2.126	3.937	.500	2.812	10010S
1	Z-1616LT	1.614	2.126	3.937	.500	2.812	10010S
1-1/16	Z-1617LT	1.732	2.126	3.937	.500	2.812	10010S
1-1/8	Z-1618LT	1.732	2.126	3.937	.500	2.812	10010S
1-3/16	Z-1619LT	1.929	2.126	3.937	1.299	2.812	10010S
1-1/4	Z-1620LT	1.929	2.126	3.937	1.339	2.812	10010S
1-5/16	Z-1621LT	2.047	2.126	3.937	1.496	2.812	10010S
1-3/8	Z-1622LT	2.047	2.126	3.937	1.496	2.812	10010S
1-7/16	Z-1623LT	2.126	2.126	3.937	1.496	2.812	10010S
1-1/2	Z-1624LT	2.224	2.126	3.937	1.732	2.812	10010S
1-9/16	Z-1625LT	2.244	2.126	3.937	1.732	2.812	10010S
1-5/8	Z-1626LT	2.362	2.126	3.937	1.732	2.812	10010S
1-11/16	Z-1627LT	2.480	2.126	3.937	1.968	2.812	10010S
1-3/4	Z-1628LT	2.638	2.126	3.937	2.008	2.812	10010S
1-13/16	Z-1629LT	2.638	2.126	3.937	2.008	2.812	10010S

Deep Metric Thinwall Sizes

SIZE mm	PART#	D1 mm	D2 mm	L mm	T mm	C mm	RET RING
22	Z-16M22LT	38	54	100	20	71	10010S
23	Z-16M23LT	38	54	100	24	71	10010S
24	Z-16M24LT	38	54	100	24	71	10010S
25	Z-16M25LT	41	54	100	26	71	10010S
26	Z-16M26LT	44	54	100	26	71	10010S
27	Z-16M27LT	44	54	100	26	71	10010S
28	Z-16M28LT	44	54	100	28	71	10010S
29	Z-16M29LT	44	54	100	28	71	10010S
30	Z-16M30LT	49	54	100	33	71	10010S
31	Z-16M31LT	49	54	100	33	71	10010S
32	Z-16M32LT	49	54	100	33	71	10010S
33	Z-16M33LT	52	54	100	34	71	10010S
34	Z-16M34LT	52	54	100	34	71	10010S
35	Z-16M35LT	52	54	100	38	71	10010S
36	Z-16M36LT	54	54	100	38	71	10010S
37	Z-16M37LT	54	54	100	38	71	10010S
38	Z-16M38LT	54	54	100	43	71	10010S
39	Z-16M39LT	54	54	100	43	71	10010S
40	Z-16M40LT	54	54	100	43	71	10010S
41	Z-16M41LT	54	54	100	44	71	10010S
42	Z-16M42LT	54	54	100	44	71	10010S
43	Z-16M43LT	54	54	100	50	71	10010S
44	Z-16M44LT	54	54	100	50	71	10010S
45	Z-16M45LT	54	54	100	51	71	10010S
46	Z-16M46LT	54	54	100	51	71	10010S

See page 83 for information on "special" sockets. OZAT routinely manufactures extra deep, extra heavy, spark resistant, special shape, or special drive type sockets.

1" SQUARE DRIVE

SIX POINT IMPACT SOCKETS

Standard Metric Sizes

SIZE mm	PART#	D1 mm	D2 mm	L mm	T mm	C mm	RET RING
19	Z-16M19	36	54	55	9.5	26	10010S
20	Z-16M20	37	54	55	10	26	10010S
21	Z-16M21	38	54	55	10	26	10010S
22	Z-16M22	40	54	55	10	26	10010S
23	Z-16M23	41	54	55	12	26	10010S
24	Z-16M24	42	54	55	12	26	10010S
25	Z-16M25	43	54	55	13	26	10010S
26	Z-16M26	45	54	55	13	26	10010S
27	Z-16M27	46	54	55	13	26	10010S
28	Z-16M28	47	54	55	14	26	10010S
29	Z-16M29	48	54	57	14	28	10010S
30	Z-16M30	50	54	57	16.5	28	10010S
31	Z-16M31	51	54	57	16.5	28	10010S
32	Z-16M32	51	54	57	16.5	28	10010S
33	Z-16M33	54	54	57	17	28	10010S
34	Z-16M34	54	54	60	19	31	10010S
35	Z-16M35	54	54	60	19	31	10010S
36	Z-16M36	54	54	60	19	31	10010S
37	Z-16M37	57	54	60	19	31	10010S
38	Z-16M38	60	54	64	22	35	10010S
39	Z-16M39	60	54	64	21.5	35	10010S
40	Z-16M40	63	54	64	21.5	35	10010S
41	Z-16M41	63	54	64	22	35	10010S
42	Z-16M42	63	54	64	21.5	35	10010S
43	Z-16M43	67	54	69	25	40	10010S
44	Z-16M44	67	54	69	21.5	40	10010S
45	Z-16M45	70	54	69	21.5	40	10010S
46	Z-16M46	70	54	69	25.5	40	10010S
47	Z-16M47	70	54	69	23.5	40	10010S
48	Z-16M48	73	54	72	23.5	43	10010S
49	Z-16M49	73	54	72	27	43	10010S
50	Z-16M50	73	54	72	23.5	43	10010S
51	Z-16M51	73	54	72	27	43	10010S
52	Z-16M52	78	54	72	27	43	10010S
54	Z-16M54	82	54	76	30	47	10010S
55	Z-16M55	82	54	76	27	47	10010S
56	Z-16M56	82	54	75	28	46	10010S
57	Z-16M57	82	54	80	33	51	10010S
58	Z-16M58	86	54	75	28	46	10010S
59	Z-16M59	86	54	82	33	53	10010S
60	Z-16M60	86	54	75	28	46	10010S
61	Z-16M61	88	54	85	28	56	10010S
62	Z-16M62	92	54	85	35	56	10010S
65	Z-16M65	92	54	85	35	56	10010S
67	Z-16M67	92	54	88	38	62	10010S
70	Z-16M70	96	54	88	38	79	10010S
73	Z-16M73	100	86	92	41	83	10021S
75	Z-16M75	100	86	92	41	83	10021S
76	Z-16M76	105	86	97	44	68	10021S
80	Z-16M80	105	86	97	37	59	10021S
85	Z-16M85	115	86	100	40	63	10021S
86	Z-16M86	115	86	104	49	75	10021S
90	Z-16M90	127	86	104	43	68	10021S
95	Z-16M95	135	86	106	49	77	10021S
100	Z-16M100	135	86	112	54	83	10021S
105	Z-16M105	145	127	112	54	83	*
110	Z-16M110	150	127	122	62	93	*
115	Z-16M115	155	127	122	57	91	*

* Requires retaining pin and ring, Pin = P16127, Ring = R16127

Deep Metric Sizes

SIZE mm	PART#	D1 mm	D2 mm	L mm	T mm	C mm	RET RING
19	Z-16M19L	36	54	100	9.5	71	10010S
20	Z-16M20L	37	54	100	10	71	10010S
21	Z-16M21L	38	54	100	10	71	10010S
22	Z-16M22L	40	54	100	10	71	10010S
23	Z-16M23L	41	54	100	12	71	10010S
24	Z-16M24L	42	54	100	12	71	10010S
25	Z-16M25L	43	54	100	13	71	10010S
26	Z-16M26L	45	54	100	13	71	10010S
27	Z-16M27L	46	54	100	13	71	10010S
28	Z-16M28L	47	54	100	14	71	10010S
29	Z-16M29L	48	54	100	14	71	10010S
30	Z-16M30L	50	54	100	16.5	71	10010S
31	Z-16M31L	51	54	100	16.5	71	10010S
32	Z-16M32L	51	54	100	16.5	71	10010S
33	Z-16M33L	54	54	100	17	71	10010S
34	Z-16M34L	54	54	100	19	71	10010S
35	Z-16M35L	54	54	100	19	71	10010S
36	Z-16M36L	54	54	100	19	71	10010S
37	Z-16M37L	57	54	100	19	71	10010S
38	Z-16M38L	60	54	100	22	71	10010S
39	Z-16M39L	60	54	100	21.5	71	10010S
40	Z-16M40L	63	54	100	21.5	71	10010S
41	Z-16M41L	63	54	100	22	71	10010S
42	Z-16M42L	63	54	100	21.5	71	10010S
43	Z-16M43L	67	54	100	25	71	10010S
44	Z-16M44L	67	54	100	21.5	71	10010S
45	Z-16M45L	70	54	100	21.5	71	10010S
46	Z-16M46L	70	54	100	25.5	71	10010S
47	Z-16M47L	70	54	100	23.5	71	10010S
48	Z-16M48L	73	54	100	23.5	71	10010S
49	Z-16M49L	73	54	100	27	71	10010S
50	Z-16M50L	73	54	100	23.5	71	10010S
51	Z-16M51L	73	54	100	27	71	10010S
52	Z-16M52L	78	54	100	27	71	10010S
54	Z-16M54L	82	54	104	30	75	10010S
55	Z-16M55L	82	54	104	27	75	10010S
56	Z-16M56L	82	54	105	28	76	10010S
57	Z-16M57L	82	54	105	33	76	10010S
58	Z-16M58L	86	54	105	28	76	10010S
59	Z-16M59L	86	54	112	33	83	10010S
60	Z-16M60L	86	54	105	28	83	10010S
61	Z-16M61L	88	54	112	28	83	10010S
62	Z-16M62L	92	54	118	35	89	10010S
65	Z-16M65L	92	54	118	35	89	10010S
67	Z-16M67L	92	54	118	38	89	10010S
70	Z-16M70L	96	54	124	38	95	10010S
73	Z-16M73L	100	86	124	41	95	10021S
75	Z-16M75L	100	86	124	41	95	10021S
76	Z-16M76L	105	86	130	44	101	10021S
80	Z-16M80L	105	86	132	37	103	10021S
85	Z-16M85L	115	86	132	40	103	10021S
86	Z-16M86L	115	86	140	49	111	10021S
90	Z-16M90L	127	86	140	43	111	10021S
95	Z-16M95L	135	86	140	49	111	10021S
100	Z-16M100L	135	86	143	54	114	10021S
105	Z-16M105L	145	127	143	54	114	*
110	Z-16M110L	150	127	149	62	120	*
115	Z-16M115L	155	127	149	57	120	*

* Requires retaining pin and ring, Pin = P16127, Ring = R16127

1" SQUARE DRIVE

HEX DRIVER SOCKETS

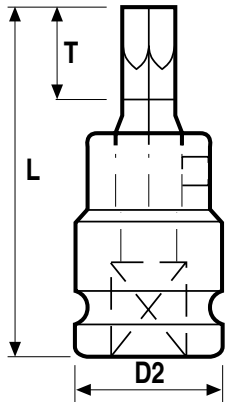

Fractional Sizes

SIZE in	PART#	D2 in	L in	T in	RET RING
1/2	Z-1608H	2.126	2.91	1.16	10010S
9/16	Z-1609H	2.126	2.91	1.16	10010S
5/8	Z-1610H	2.126	2.91	1.16	10010S
3/4	Z-1612H	2.126	2.91	1.16	10010S
13/16	Z-1613H	2.126	3.07	1.32	10010S
7/8	Z-1614H	2.126	3.07	1.32	10010S
1	Z-1616H	2.126	3.07	1.32	10010S
1-1/16	Z-1617H	2.126	3.23	1.48	10010S
1-1/8	Z-1618H	2.126	3.23	1.48	10010S
1-3/16	Z-1619H	2.126	3.23	1.48	10010S
1-1/4	Z-1620H	2.126	3.43	1.68	10010S

Note: 1 piece construction

Metric Sizes

SIZE mm	PART#	D2 mm	L mm	T mm	RET RING
10	Z-16M10H	2.126	2.91	1.16	10010S
12	Z-16M12H	2.126	2.91	1.16	10010S
14	Z-16M14H	2.126	2.91	1.16	10010S
17	Z-16M17H	2.126	2.91	1.16	10010S
19	Z-16M19H	2.126	2.91	1.16	10010S
22	Z-16M22H	2.126	3.07	1.32	10010S
24	Z-16M24H	2.126	3.07	1.32	10010S
27	Z-16M27H	2.126	3.23	1.48	10010S
30	Z-16M30H	2.126	3.23	1.48	10010S
32	Z-16M32H	2.126	3.43	1.68	10010S

Note: 1 piece construction

2-Part In-Hex Sizes

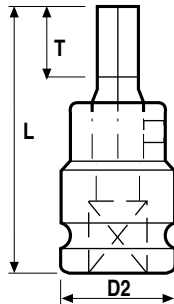

HEX in	HEX mm	PART#	D2 mm	L mm	T mm	Weight gr	RET RING	REPLACEMENT HEX BIT
1/2		Z-1608V	54	74	19	800	10010S	H08
9/16		Z-1609V	54	74	21	800	10010S	H09
5/8		Z-1610V	54	74	24	800	10010S	H10
3/4		Z-1612V	54	74	26	800	10010S	H12
13/16		Z-1613V	54	89	26	900	10010S	H13
7/8		Z-1614V	54	89	26	900	10010S	H14
1		Z-1616V	54	109	30	1000	10010S	H16
1-1/16		Z-1617V	54	111	32	1000	10010S	H17
1-1/8		Z-1618V	54	111	32	1000	10010S	H18
1-3/16		Z-1619V	54	115	36	1000	10010S	H19
1-1/4		Z-1620V	54	117	38	1000	10010S	H20
	10	Z-16M10V	54	74	16	800	10010S	HM10
	12	Z-16M12V	54	74	18	800	10010S	HM12
	14	Z-16M14V	54	74	21	800	10010S	HM14
	17	Z-16M17V	54	74	26	800	10010S	HM17
	19	Z-16M19V	54	89	26	900	10010S	HM19
	22	Z-16M22V	54	89	26	900	10010S	HM22
	24	Z-16M24V	54	89	26	900	10010S	HM24
	27	Z-16M27V	54	111	32	1000	10010S	HM27
	30	Z-16M30V	54	115	36	1000	10010S	HM30
	32	Z-16M32V	54	117	38	1000	10010S	HM32

Note: 2 piece construction

Budd Wheel Socket Sizes

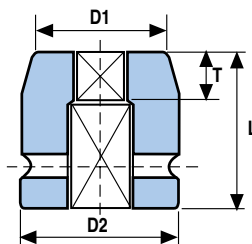

SIZE	PART#	D1	D2	L	T	RET RING
17 mm	Z-16M17B	40 mm	54 mm	55 mm	9 mm	10010S
21 mm	Z-16M21B	47 mm	54 mm	55 mm	10 mm	10010S
13/16"	Z-1613B	1.85"	2.126"	2.145"	0.472"	10010S
15/16"	Z-1615B	2.07"	2.126"	2.340"	0.512"	10010S
13/16"	Z-1613BL	1.85"	2.126"	3.900"	0.472"	10010S
15/16"	Z-1615BL	2.07"	2.126"	3.900"	0.512"	10010S
13/16" X 1-1/2"	Z-1624BS	2.24"	2.126"	3.900"	0.571"	10010S

1" SQUARE DRIVE

12 POINT IMPACT SOCKETS

Standard Socket Sizes

SIZE in	SIZE mm	PART#	D1 mm	D2 mm	L mm	T mm	Weight gr	RET RING
3/4	19	DH-1612DM19	36	54	55	9.5	600	10010S
13/16		DH-1613	38	54	55	11.0	600	10010S
7/8		DH-1614	40	54	55	13.0	600	10010S
15/16		DH-1615	41	54	55	13.0	600	10010S
1		DH-1616	43	54	55	13.0	600	10010S
1-1/16	27	DH-1617M27	46	54	55	13.0	600	10010S
1-1/8		DH-1618	48	54	57	16.5	630	10010S
1-3/16	30	DH-1619M30	50	54	57	16.5	630	10010S
1-1/4		DH-1620	51	54	57	17.0	630	10010S
1-5/16		DH-1621	54	54	60	19.0	650	10010S
1-3/8	35	DH-1622M35	54	54	60	19.0	650	10010S
1-7/16		DH-1623	54	54	60	19.0	650	10010S
1-1/2	38	DH-1624M38	60	54	64	22.0	760	10010S
1-9/16		DH-1625	60	54	64	22.0	760	10010S
1-5/8	41	DH-1626M41	63	54	64	22.0	800	10010S
1-11/16	43	DH-1627M43	67	54	69	25.0	950	10010S
1-3/4		DH-1628	70	54	69	25.5	1000	10010S
1-13/16	46	DH-1629M46	70	54	69	25.5	1000	10010S
1-7/8		DH-1630	70	54	72	27.0	1000	10010S
1-15/16	49	DH-1631M49	73	54	72	27.0	1080	10010S
2	51	DH-1632M51	73	54	72	27.0	2080	10010S
2-1/16		DH-1633	78	54	76	30.0	1240	10010S
2-1/8	54	DH-1634M54	82	54	76	30.0	1400	10010S
2-3/16		DH-1635	82	54	80	32.0	1400	10010S
2-1/4	57	DH-1636M57	82	54	80	33.0	1400	10010S
2-5/16	59	DH-1637M59	86	54	82	33.0	1500	10010S
2-3/8		DH-1638	86	54	85	35.0	1500	10010S
2-7/16	62	DH-1639M62	92	54	85	35.0	1800	10010S
2-1/2		DH-1640	92	54	85	35.0	1800	10010S
2-9/16	65	DH-1641M65	92	54	85	25.0	1800	10010S
2-5/8	67	DH-1642M67	92	54	88	38.0	1800	10010S
2-11/16		DH-1643	96	54	88	38.0	1800	10010S
2-3/4	70	DH-1644M70	96	54	88	38.0	1800	10010S
2-13/16		DH-1645	100	86	92	40.0	2700	10021S
2-7/8	73	DH-1646M73	100	86	92	41.0	2700	10021S
2-15/16	75	DH-1647M75	100	86	92	41.0	2700	10021S
3	76	DH-1648M76	105	86	97	44.0	3200	10021S

Standard Socket Sizes Cont.

SIZE in	SIZE mm	PART#	D1 mm	D2 mm	L mm	T mm	Weight gr	RET RING
3-1/16		DH-1649	105	86	97	44.0	3200	10021S
3-1/8		DH-1650	105	86	97	44.0	3200	10021S
3-3/16		DH-1651	109	86	100	47.0	3200	10021S
3-1/4		DH-1652	109	86	100	47.0	3200	10021S
3-5/16		DH-1653	109	86	100	47.0	3200	10021S
3-3/8	86	DH-1654M86	115	86	104	49.0	3500	10021S
3-7/16		DH-1655	121	86	104	49.0	4120	10021S
3-1/2		DH-1656	121	86	104	49.0	4120	10021S
3-9/16		DH-1657	127	86	104	49.5	4400	10021S
3-5/8		DH-1658	130	86	104	49.0	4700	10021S
3-11/16		DH-1659	130	86	104	49.0	4700	10021S
3-3/4	95	DH-1660M95	135	86	106	49.0	5200	10021S
3-13/16		DH-1661	135	86	112	54.0	5200	10021S
3-7/8		DH-1662	135	86	112	54.0	5200	10021S
3-15/16	100	DH-1663M100	135	86	112	54.0	5200	10021S
4		DH-1664	140	127	112	54.0	5500	*
4-1/16		DH-1665	140	127	112	54.0	5500	*
4-1/8	105	DH-1666M105	145	127	112	54.0	7700	*
4-3/16		DH-1667	145	127	122	62.0	8100	*
4-1/4		DH-1668	145	127	122	62.0	8100	*
4-5/16	110	DH-1669M110	150	127	122	62.0	8200	*
4-3/8		DH-1670	150	127	122	62.0	8200	*
4-7/16		DH-1671	150	127	122	62.0	9060	*
4-1/2		DH-1672	150	127	122	62.0	9060	*

* Requires retaining pin and ring, Pin = P16127, Ring = R16127

Deep Fractional Sizes

SIZE in	PART#	D1 in	D2 in	L in	T in	C in	RET RING
2	DH-11632L	2.874	2.126	3.900	1.062	2.812	10010S
2-3/16	DH-1635L	3.228	2.126	4.095	1.259	3.088	10010S
2-3/8	DH-1638L	3.386	2.126	4.368	1.378	3.560	10010S
2-9/16	DH-1641L	3.622	2.126	4.602	1.378	3.599	10010S
2-3/4	DH-1644L	3.780	2.126	4.836	1.496	3.757	10010S
2-15/16	DH-1647L	3.937	3.386	4.836	1.614	3.757	10021S
3-1/8	DH-1650L	4.291	3.386	5.460	1.929	4.072	10021S

DOUBLE SQUARE EIGHT POINT SOCKETS

Standard Fractional Sizes

SIZE in	PART#	D1 in	D2 in	L in	T in	C in	RET RING
1-5/16	DS-1621	2.480	2.126	2.262	.748	1.283	10010S
1-3/8	DS-1622	2.638	2.362	2.262	.748	1.283	10015S
1-7/16	DS-1623	2.638	2.362	2.262	.748	1.283	10015S
1-1/2	DS-1624	2.756	2.362	2.418	.866	1.441	10015S
1-9/16	DS-1625	3.071	2.362	2.418	.866	1.441	10015S
1-5/8	DS-1626	3.071	2.362	2.418	.866	1.441	10015S
1-11/16	DS-1627	3.228	2.362	2.613	.984	1.638	10015S
1-3/4	DS-1628	3.228	2.362	2.613	1.005	1.638	10015S
1-13/16	DS-1629	3.386	2.362	2.613	1.005	1.638	10015S
1-7/8	DS-1630	3.386	2.362	2.730	1.063	1.756	10015S
2	DS-1632	3.622	2.362	2.730	1.063	1.756	10015S
2-1/8	DS-1634	3.937	2.362	2.925	1.181	1.953	10015S
2-3/16	DS-1635	3.937	2.362	3.042	1.260	2.071	10015S
2-1/4	DS-1636	3.937	2.362	3.042	1.260	2.071	10015S
2-3/8	DS-1638	4.134	2.362	3.198	1.378	2.228	10015S
2-1/2	DS-1640	4.291	2.362	3.432	1.378	2.465	10015S

Note: Metric Sizes 35, 38, 41, 46, 51, 54, 57 are also available by special order. (POR)

Deep Fractional Sizes

SIZE in	PART#	D1 in	D2 in	L in	T in	C in	RET RING
1-5/16	DS-1621L	2.480	2.126	3.159	.748	2.189	10010S
1-3/8	DS-1622L	2.638	2.362	3.159	.748	2.189	10015S
1-7/16	DS-1623L	2.638	2.362	3.159	.748	2.189	10015S
1-1/2	DS-1624L	2.756	2.362	3.393	.866	2.322	10015S
1-9/16	DS-1625L	3.071	2.362	3.432	.866	2.322	10015S
1-5/8	DS-1626L	3.071	2.362	3.432	.866	2.322	10015S
1-11/16	DS-1627L	3.228	2.362	3.432	.984	2.322	10015S
1-3/4	DS-1628L	3.228	2.362	3.432	1.005	2.322	10015S
1-13/16	DS-1629L	3.386	2.362	3.432	1.005	2.322	10015S
1-7/8	DS-1630L	3.386	2.362	3.432	1.063	2.322	10015S
2	DS-1632L	3.622	2.362	3.432	1.063	2.322	10015S
2-1/8	DS-1634L	3.937	2.362	3.783	1.181	2.819	10015S
2-3/16	DS-1635L	3.937	2.362	3.783	1.260	2.819	10015S
2-1/4	DS-1636L	3.937	2.362	3.900	1.260	2.937	10015S
2-3/8	DS-1638L	4.134	2.362	3.900	1.378	2.937	10015S
2-1/2	DS-1640L	4.291	2.362	3.900	1.378	2.937	10015S

Note: Metric Sizes 35, 38, 41, 46, 51, 54, 57 are also available by special order. (POR)

1" SQUARE DRIVE

ACCESSORIES

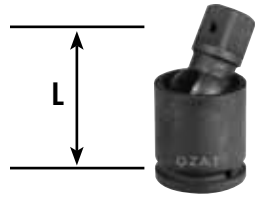

Universal Joint

SIZE in	PART#	L (hole to hole) in	RET RING
1	U1616	4.25	10010S

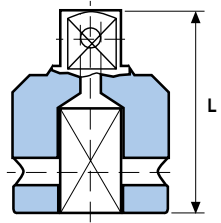

Adapters

PART#	FEMALE in	MALE in	L in	RET RING
A1612	1	3/4	2.750	10010S
A1624	1	1-1/2	3.346	10010S
A1695	1	#5 Spline	4.330	10010S

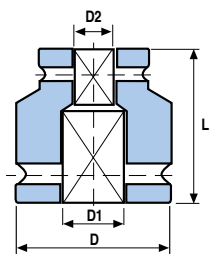

Double Ended Female Adapters

PART#	D1 in	D2 in	L in	D in	RET RINGS (D1) (D2)
AN1612	1	3/4	2.48	2.13	10010S 10006S
AN1616	1	1	2.32	2.13	10010S 10010S
AN2416	1-1/2	1	3.27	3.39	10020S 10010S

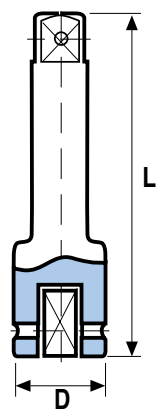

Extensions

PART#	D in	L in	RET RING
E1604	2.125	4	10010S
E1605	2.125	5	10010S
E1607	2.125	7	10010S
E1610	2.125	10	10010S
E1613	2.125	13	10010S

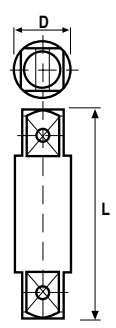

Double Ended Male Extensions

PART#	D in	L in
Z1603	1.3	3
Z1604	1.3	4
Z1605	1.3	5
Z1606	1.3	6
Z1607	1.3	7
Z1610	1.3	10
Z1613	1.3	13
Z1615	1.3	15
Z1616	1.3	16
Z1617	1.3	17

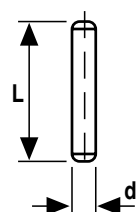
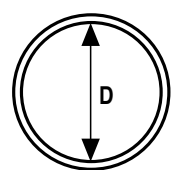

Retaining Pins and Rings

SQUARE DRIVE	SOCKET SIZES	PIN#	RING#	d in	L in	D in
1	Up To 2-3/4" (70mm)	P1654	R1654	.195	1.750	1.750
1	From 2-3/4" To 3-15/16" (100mm)	P1686	R1686	.195	3.000	3.000
1	Above 3-15/16" (100mm)	P16127	R16127	.195	4.600	4.600

1-1/2" SQUARE DRIVE

SIX POINT IMPACT SOCKETS

The exceptional strength of the OZAT 1-1/2" drive sockets often makes them the preferred choice of hydraulic bolting specialists.

Specialty sockets for the precision bolting market are available from ATP

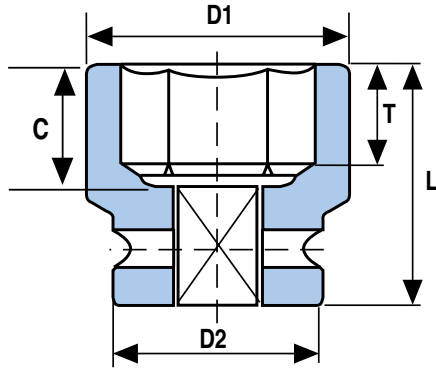

Standard Fractional Sizes



SIZE in	PART#	D1 in	D2 in	L in	T in	C in	RET RING
1-5/16	Z-2421	2.402	3.386	2.925	.748	1.328	10021S
1-3/8	Z-2422	2.480	3.386	2.925	.748	1.328	10021S
1-7/16	Z-2423	2.520	3.386	3.120	.748	1.525	10021S
1-1/2	Z-2424	2.520	3.386	3.120	.866	1.525	10021S
1-9/16	Z-2425	2.677	3.386	3.120	.866	1.525	10021S
1-5/8	Z-2426	2.795	3.386	3.120	.866	1.525	10021S
1-11/16	Z-2427	2.874	3.386	3.120	.984	1.525	10021S
1-3/4	Z-2428	2.953	3.386	3.120	1.004	1.525	10021S
1-13/16	Z-2429	2.953	3.386	3.120	1.004	1.525	10021S
1-7/8	Z-2430	3.150	3.386	3.198	1.036	1.603	10021S
1-15/16	Z-2431	3.150	3.386	3.198	1.063	1.603	10021S
2	Z-2432	3.150	3.386	3.198	1.063	1.603	10021S
2-1/16	Z-2433	3.386	3.386	3.471	1.181	1.840	10021S
2-1/8	Z-2434	3.386	3.386	3.471	1.181	1.840	10021S
2-3/16	Z-2435	3.386	3.386	3.588	1.260	1.958	10021S
2-1/4	Z-2436	3.386	3.386	3.588	1.280	1.958	10021S
2-5/16	Z-2437	3.622	3.386	3.588	1.300	1.958	10021S
2-3/8	Z-2438	3.622	3.386	3.744	1.378	2.115	10021S
2-7/16	Z-2439	3.780	3.386	3.744	1.378	2.115	10021S
2-1/2	Z-2440	3.937	3.386	3.744	1.378	2.115	10021S
2-9/16	Z-2441	3.937	3.386	3.744	1.378	2.115	10021S
2-5/8	Z-2442	3.937	3.386	3.939	1.496	2.312	10021S
2-11/16	Z-2443	4.134	3.386	3.939	1.496	2.312	10021S
2-3/4	Z-2444	4.134	3.386	3.939	1.496	2.312	10021S
2-13/16	Z-2445	4.291	3.386	4.095	1.575	2.509	10021S
2-7/8	Z-2446	4.291	3.386	4.095	1.614	2.509	10021S
2-15/16	Z-2447	4.291	3.386	4.095	1.614	2.509	10021S
3	Z-2448	4.528	3.386	4.290	1.732	2.706	10021S
3-1/16	Z-2449	4.528	3.386	4.290	1.732	2.706	10021S
3-1/8	Z-2450	4.528	3.386	4.290	1.770	2.706	10021S
3-3/16	Z-2451	4.764	3.386	4.524	1.850	3.099	10021S
3-1/4	Z-2452	4.764	3.386	4.524	1.850	3.099	10021S
3-5/16	Z-2453	4.764	3.386	4.524	1.850	3.099	10021S
3-3/8	Z-2454	5.000	3.386	4.524	1.930	3.099	10021S
3-7/16	Z-2455	5.000	3.386	4.602	1.930	3.099	10021S
3-1/2	Z-2456	5.118	3.386	4.602	1.930	3.099	10021S
3-9/16	Z-2457	5.118	3.386	4.602	1.930	3.099	10021S
3-5/8	Z-2458	5.315	5.000	4.602	1.930	3.099	*
3-11/16	Z-2459	5.315	5.000	4.602	1.930	3.099	*
3-3/4	Z-2460	5.315	5.000	4.602	1.930	3.296	*
3-13/16	Z-2461	5.512	5.000	4.875	2.125	3.296	*
3-7/8	Z-2462	5.512	5.000	4.875	2.125	3.296	*
3-15/16	Z-2463	5.512	5.000	4.875	2.125	3.296	*
4	Z-2464	5.709	5.000	4.875	2.125	3.296	*
4-1/16	Z-2465	5.709	5.000	4.875	2.125	3.296	*
4-1/8	Z-2466	5.906	5.000	4.875	2.126	3.296	*
4-3/16	Z-2467	5.906	5.000	5.343	2.440	3.296	*
4-1/4	Z-2468	5.906	5.000	5.343	2.440	3.690	*
4-5/16	Z-2469	6.102	5.000	5.343	2.440	3.690	*
4-3/8	Z-2470	6.102	5.000	5.343	2.440	3.690	*
4-7/16	Z-2471	6.102	5.000	5.343	2.440	3.690	*
4-1/2	Z-2472	6.299	5.000	5.343	2.440	3.690	*
4-5/8	Z-2474	6.496	5.000	5.577	2.640	4.084	*
4-3/4	Z-2476	6.693	5.000	5.655	2.640	4.084	*
4-7/8	Z-2478	6.693	5.000	5.655	2.640	4.084	*
5	Z-2480	7.087	5.000	5.850	2.830	4.281	*
5-1/8	Z-2482	7.087	5.000	6.162	2.990	4.674	*
5-3/16	Z-2483	7.087	5.000	6.162	2.990	4.674	*
5-1/4	Z-2484	7.480	5.000	6.162	2.980	4.574	*
5-3/8	Z-2486	7.480	5.000	6.162	2.990	4.674	*

* Requires retaining pin and ring, Pin = P24127, Ring = R24127

1-1/2" SQUARE DRIVE

SIX POINT IMPACT SOCKETS

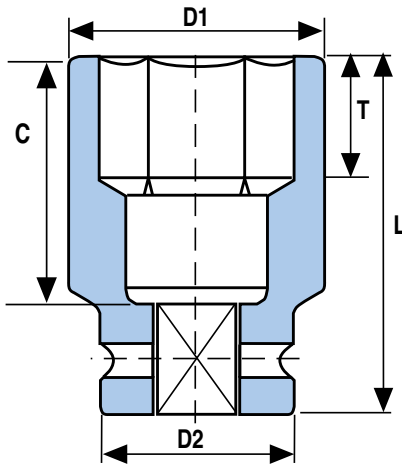

Deep Fractional Sizes

SIZE in	PART#	D1 in	D2 in	L in	T in	C in	RET RING
1-5/16	Z-2421L	2.402	3.386	5.460	.748	3.887	10021S
1-3/8	Z-2422L	2.480	3.386	5.460	.748	3.887	10021S
1-7/16	Z-2423L	2.520	3.386	5.460	.748	3.887	10021S
1-1/2	Z-2424L	2.520	3.386	5.460	.866	3.887	10021S
1-9/16	Z-2425L	2.677	3.386	5.460	.866	3.887	10021S
1-5/8	Z-2426L	2.795	3.386	5.460	.866	3.887	10021S
1-11/16	Z-2427L	2.874	3.386	5.460	.984	3.887	10021S
1-3/4	Z-2428L	2.953	3.386	5.460	1.004	3.887	10021S
1-13/16	Z-2429L	2.953	3.386	5.460	1.004	3.887	10021S
1-7/8	Z-2430L	3.150	3.386	5.460	1.036	3.887	10021S
1-15/16	Z-2431L	3.150	3.386	5.460	1.063	3.887	10021S
2	Z-2432L	3.150	3.386	5.460	1.063	3.887	10021S
2-1/16	Z-2433L	3.386	3.386	5.460	1.181	3.887	10021S
2-1/8	Z-2434L	3.386	3.386	5.460	1.181	3.887	10021S
2-3/16	Z-2435L	3.386	3.386	5.460	1.260	3.887	10021S
2-1/4	Z-2436L	3.386	3.386	5.460	1.280	3.887	10021S
2-5/16	Z-2437L	3.622	3.386	5.460	1.300	3.887	10021S
2-3/8	Z-2438L	3.622	3.386	5.460	1.378	3.887	10021S
2-7/16	Z-2439L	3.780	3.386	5.460	1.378	3.887	10021S
2-1/2	Z-2440L	3.937	3.386	5.460	1.378	3.887	10021S
2-9/16	Z-2441L	3.937	3.386	5.460	1.378	3.887	10021S
2-5/8	Z-2442L	3.937	3.386	5.460	1.496	3.887	10021S
2-11/16	Z-2443L	4.134	3.386	5.460	1.496	3.887	10021S
2-3/4	Z-2444L	4.134	3.386	5.460	1.496	3.887	10021S
2-13/16	Z-2445L	4.291	3.386	5.460	1.575	3.887	10021S
2-7/8	Z-2446L	4.291	3.386	5.460	1.614	3.887	10021S
2-15/16	Z-2447L	4.291	3.386	5.460	1.614	3.887	10021S
3	Z-2448L	4.528	3.386	5.460	1.732	3.887	10021S
3-1/16	Z-2449L	4.528	3.386	5.460	1.732	3.887	10021S
3-1/8	Z-2450L	4.528	3.386	5.460	1.770	3.887	10021S
3-3/16	Z-2451L	4.764	3.386	5.460	1.850	3.887	10021S
3-1/4	Z-2452L	4.764	3.386	5.460	1.850	3.887	10021S
3-5/16	Z-2453L	4.764	3.386	5.460	1.850	3.887	10021S
3-3/8	Z-2454L	5.000	3.386	5.460	1.930	3.887	10021S
3-7/16	Z-2455L	5.000	3.386	5.460	1.930	3.887	10021S
3-1/2	Z-2456L	5.118	3.386	5.460	1.930	3.887	10021S
3-9/16	Z-2457L	5.118	3.386	5.460	1.930	3.887	10021S
3-5/8	Z-2458L	5.315	5.000	5.460	1.930	3.887	*
3-11/16	Z-2459L	5.315	5.000	5.460	1.930	4.281	*
3-3/4	Z-2460L	5.315	5.000	5.850	1.930	4.281	*
3-13/16	Z-2461L	5.512	5.000	5.850	2.125	4.281	*
3-7/8	Z-2462L	5.512	5.000	5.850	2.125	4.281	*
3-15/16	Z-2463L	5.512	5.000	5.850	2.125	4.281	*
4	Z-2464L	5.709	5.000	5.850	2.125	4.281	*
4-1/16	Z-2465L	5.709	5.000	5.850	2.125	4.281	*
4-1/8	Z-2466L	5.906	5.000	5.850	2.126	4.281	*
4-3/16	Z-2467L	5.906	5.000	5.850	2.440	4.281	*
4-1/4	Z-2468L	5.906	5.000	6.240	2.440	4.674	*
4-5/16	Z-2469L	6.102	5.000	6.240	2.440	4.674	*
4-3/8	Z-2470L	6.102	5.000	6.240	2.440	4.674	*
4-7/16	Z-2471L	6.102	5.000	6.240	2.440	4.674	*
4-1/2	Z-2472L	6.299	5.000	6.240	2.440	4.674	*
4-5/8	Z-2474L	6.496	5.000	6.630	2.640	5.068	*
4-3/4	Z-2476L	6.693	5.000	6.630	2.640	5.068	*
4-7/8	Z-2478L	6.693	5.000	6.630	2.640	5.068	*
5	Z-2480L	7.087	5.000	7.020	2.830	5.462	*
5-1/8	Z-2482L	7.087	5.000	7.215	2.990	5.658	*
5-3/16	Z-2483L	7.087	5.000	7.215	2.990	5.658	*
5-3/8	Z-2486L	7.480	5.000	7.215	2.990	5.658	*

* Requires retaining pin and ring, Pin = P24127, Ring = R24127

1-1/2" SQUARE DRIVE

SIX POINT IMPACT SOCKETS

Standard Metric Sizes



SIZE mm	PART#	D1 mm	D2 mm	L mm	T mm	C mm	RET RING
32	Z-24M32	60	86	75	16.5	34	10021S
33	Z-24M33	60	86	75	17	34	10021S
34	Z-24M34	60	86	75	17	34	10021S
35	Z-24M35	60	86	75	19	34	10021S
36	Z-24M36	64	86	80	19	39	10021S
37	Z-24M37	64	86	80	19	39	10021S
38	Z-24M38	64	86	80	22	39	10021S
39	Z-24M39	70	86	80	21.5	39	10021S
40	Z-24M40	70	86	80	21.5	39	10021S
41	Z-24M41	70	86	80	22	39	10021S
42	Z-24M42	70	86	80	21.5	39	10021S
43	Z-24M43	75	86	80	25	39	10021S
44	Z-24M44	75	86	80	21.5	39	10021S
45	Z-24M45	75	86	80	21.5	39	10021S
46	Z-24M46	75	86	80	25.5	39	10021S
47	Z-24M47	75	86	80	23.5	39	10021S
48	Z-24M48	80	86	82	23.5	41	10021S
49	Z-24M49	80	86	82	27	41	10021S
50	Z-24M50	80	86	82	23.5	41	10021S
51	Z-24M51	80	86	82	27	41	10021S
52	Z-24M52	80	86	82	27	41	10021S
54	Z-24M54	86	86	89	30	47	10021S
55	Z-24M55	86	86	89	27	47	10021S
56	Z-24M56	86	86	92	28	50	10021S
57	Z-24M57	86	86	92	32.5	50	10021S
58	Z-24M58	92	86	92	28	50	10021S
59	Z-24M59	92	86	92	33	50	10021S
60	Z-24M60	92	86	92	28	50	10021S
61	Z-24M61	96	86	96	28	54	10021S
62	Z-24M62	96	86	96	35	54	10021S
65	Z-24M65	100	86	96	35	54	10021S
67	Z-24M67	100	86	101	38	59	10021S
70	Z-24M70	105	86	101	38	59	10021S
73	Z-24M73	109	86	105	41	64	10021S
75	Z-24M75	109	86	105	41	64	10021S
76	Z-24M76	115	86	110	44	69	10021S
80	Z-24M80	115	86	110	37	69	10021S
85	Z-24M85	121	86	116	40	79	10021S
86	Z-24M86	127	86	116	49	79	10021S
90	Z-24M90	130	86	118	43	79	10021S
95	Z-24M95	135	127	118	49	84	*
100	Z-24M100	140	127	125	54	84	*
105	Z-24M105	150	127	125	54	84	*
110	Z-24M110	155	127	137	62	94	*
115	Z-24M115	160	127	137	57	94	*
120	Z-24M120	165	127	145	67	104	*
125	Z-24M125	170	127	145	67	104	*
130	Z-24M130	180	127	158	76	119	*

* Requires retaining pin and ring, Pin = P24127, Ring = R24127

Deep Metric Sizes



SIZE mm	PART#	D1 mm	D2 mm	L mm	T mm	C mm	RET RING
32	Z-24M32L	60	86	140	16.5	99	10021S
33	Z-24M33L	60	86	140	17	99	10021S
34	Z-24M34L	60	86	140	17	99	10021S
35	Z-24M35L	60	86	140	19	99	10021S
36	Z-24M36L	64	86	140	19	99	10021S
37	Z-24M37L	64	86	140	19	99	10021S
38	Z-24M38L	64	86	140	22	99	10021S
39	Z-24M39L	70	86	140	21.5	99	10021S
40	Z-24M40L	70	86	140	21.5	99	10021S
41	Z-24M41L	70	86	140	22	99	10021S
42	Z-24M42L	70	86	140	21.5	99	10021S
43	Z-24M43L	75	86	140	25	99	10021S
44	Z-24M44L	75	86	140	21.5	99	10021S
45	Z-24M45L	75	86	140	21.5	99	10021S
46	Z-24M46L	75	86	140	25.5	99	10021S
47	Z-24M47L	75	86	140	23.5	99	10021S
48	Z-24M48L	80	86	140	23.5	99	10021S
49	Z-24M49L	80	86	140	27	99	10021S
50	Z-24M50L	80	86	140	23.5	99	10021S
51	Z-24M51L	80	86	140	27	99	10021S
52	Z-24M52L	80	86	140	27	99	10021S
54	Z-24M54L	86	86	140	30	99	10021S
55	Z-24M55L	86	86	140	27	99	10021S
56	Z-24M56L	86	86	140	28	99	10021S
57	Z-24M57L	86	86	140	32.5	99	10021S
58	Z-24M58L	92	86	140	28	99	10021S
59	Z-24M59L	92	86	140	33	99	10021S
60	Z-24M60L	92	86	140	28	99	10021S
61	Z-24M61L	96	86	140	28	99	10021S
62	Z-24M62L	96	86	140	35	99	10021S
65	Z-24M65L	100	86	140	35	99	10021S
67	Z-24M67L	100	86	140	38	99	10021S
70	Z-24M70L	105	86	140	38	99	10021S
73	Z-24M73L	109	86	140	41	99	10021S
75	Z-24M75L	109	86	140	41	99	10021S
76	Z-24M76L	115	86	140	44	99	10021S
80	Z-24M80L	115	86	140	37	99	10021S
85	Z-24M85L	121	86	140	40	99	10021S
86	Z-24M86L	127	86	140	49	99	10021S
90	Z-24M90L	130	86	140	43	99	10021S
95	Z-24M95L	135	127	150	49	109	*
100	Z-24M100L	140	127	150	54	109	*
105	Z-24M105L	150	127	150	54	109	*
110	Z-24M110L	155	127	160	62	119	*
115	Z-24M115L	160	127	160	57	119	*
120	Z-24M120L	165	127	170	67	129	*
125	Z-24M125L	170	127	170	67	129	*
130	Z-24M130L	180	127	185	76	144	*

* Requires retaining pin and ring, Pin = P24127, Ring = R24127

1-1/2" SQUARE DRIVE

12 POINT IMPACT SOCKETS

Standard Socket Sizes

SIZE in	SIZE mm	PART#	D1 mm	D2 mm	L mm	T mm	Weight gr	RET RING
1-5/16		DH-2421	60	86	75	19	1800	10021S
1-3/8	35	DH-2422M35	60	86	75	19	1800	10021S
1-7/16		DH-2423	64	86	80	19	2200	10021S
1-1/2	38	DH-2424M38	64	86	80	22	2200	10021S
1-9/16		DH-2425	70	86	80	22	2200	10021S
1-5/8	41	DH-2426M41	70	86	80	22	2200	10021S
1-11/16	43	DH-2427M43	75	86	80	25	2200	10021S
1-3/4		DH-2428	75	86	80	25.5	2200	10021S
1-13/16	46	DH-2429M46	75	86	80	25.5	2200	10021S
1-7/8		DH-2430	80	86	82	27	2300	10021S
1-15/16	49	DH-2431M49	80	86	82	27	2300	10021S
2	51	DH-2432M51	80	86	82	27	2300	10021S
2-1/16		DH-2433	86	86	89	30	2500	10021S
2-1/8	54	DH-2434M54	86	86	89	30	2500	10021S
	55	DH-24M55	86	86	89	30	2500	10021S
2-3/16		DH-2435	86	86	92	32	2500	10021S
2-1/4	57	DH-2436M57	86	86	92	32.5	2500	10021S
2-5/16	59	DH-2437M59	92	86	92	33	2800	10021S
2-3/8		DH-2438	92	86	96	35	2800	10021S
2-7/16	62	DH-2439M62	96	86	96	35	3200	10021S
2-1/2		DH-2440	100	86	96	35	3350	10021S
2-9/16	65	DH-2441M65	100	86	96	35	3350	10021S
2-5/8	67	DH-2442M67	100	86	101	38	3350	10021S
2-3/4	70	DH-2444M70	105	86	101	38	3600	10021S
2-7/8	73	DH-2446M73	105	86	101	44	3900	10021S
2-15/16	75	DH-2447M75	105	86	101	44	3900	10021S
2-13/16		DH-2445	105	86	105	44	3900	10021S
3	76	DH-2448M76	115	86	110	44	4500	10021S
3-1/8		DH-2450	115	86	110	44	4500	10021S
3-3/16		DH-2451	121	86	116	47	5100	10021S

Standard Socket Sizes Cont.

SIZE in	SIZE mm	PART#	D1 mm	D2 mm	L mm	T mm	Weight gr	RET RING
3-1/4		DH-2452	121	86	116	47	5100	10021S
3-5/16		DH-2453	121	86	116	47	5100	10021S
3-3/8	86	DH-2454M86	127	86	116	49	5500	10021S
3-7/16		DH-2455	127	86	118	49	5500	10021S
3-1/2		DH-2456	130	86	118	49	5600	10021S
3-9/16		DH-2457	130	86	118	49	5600	10021S
3-5/8		DH-2458	135	127	118	49	7900	*
3-11/16		DH-2459	135	127	118	49	7900	*
3-3/4	95	DH-2460M95	135	127	118	49	7900	*
3-13/16		DH-2461	140	127	125	54	8500	*
3-7/8		DH-2462	140	127	125	54	8500	*
3-15/16	100	DH-2463M100	140	127	125	54	8500	*
4		DH-2464	145	127	125	54	9000	*
4-1/16		DH-2465	145	127	125	54	9000	*
4-1/8	105	DH-2466M105	150	127	125	54	9500	*
4-3/16		DH-2467	150	127	137	54	10200	*
4-1/4		DH-2468	150	127	137	62	10200	*
4-5/16	110	DH-2469M110	155	127	137	62	10400	*
4-3/8		DH-2470	155	127	137	62	10400	*
4-7/16		DH-2471	155	127	137	62	10400	*
4-1/2		DH-2472	160	127	137	62	11500	*
4-5/8		DH-2474	165	127	143	67	12000	*
4-3/4		DH-2476	165	127	145	67	12000	*
4-7/8		DH-2478	170	127	145	67	12200	*
5		DH-2480	180	127	150	72	14800	*
5-1/8	130	DH-2482M130	180	127	158	76	14800	*
5-3/16		DH-2483	180	127	158	76	14800	*
5-3/8		DH-2486	190	127	158	76	16700	*

* Requires retaining pin and ring, Pin = P24127, Ring = R24127

2-Part In-Hex Sizes

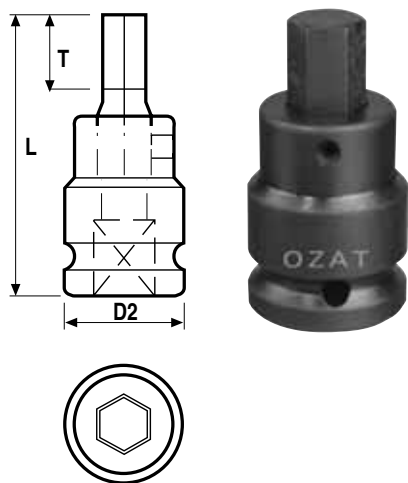

HEX in	HEX mm	PART#	D2 mm	L mm	T mm	Weight gr	RET RING	REPLACEMENT HEX BIT
1		Z-2416V	86	116	25	2600	10021S	H16
1-1/8		Z-2418V	86	119	28	2600	10021S	H18
1-1/4		Z-2420V	86	123	32	2800	10021S	H20
1-3/8		Z-2422V	86	126	35	3400	10021S	H22
1-1/2		Z-2424V	86	129	38	3400	10021S	H24
1-5/8		Z-2426V	86	132	41	3520	10021S	H26
1-3/4		Z-2428V	86	135	44	3520	10021S	H28
1-13/16		Z-2429V	86	137	46	4700	10021S	H29
1-7/8		Z-2430V	86	139	48	4900	10021S	H30
2		Z-2432V	86	142	51	4900	10021S	H32
2-1/8		Z-2434V	86	145	54	5100	10021S	H34
	22	Z-24M22V	86	113	22	2600	10021S	HM22
	24	Z-24M24V	86	115	24	2600	10021S	HM24
	27	Z-24M27V	86	118	27	2600	10021S	HM27
	30	Z-24M30V	86	121	30	2800	10021S	HM30
	32	Z-24M32V	86	123	32	2800	10021S	HM32
	36	Z-24M36V	86	127	36	3400	10021S	HM36
	38	Z-24M38V	86	129	38	3400	10021S	HM38
	41	Z-24M41V	86	132	41	3520	10021S	HM41
	46	Z-24M46V	86	137	46	4700	10021S	HM46
	50	Z-24M50V	86	141	50	4900	10021S	HM50
	55	Z-24M55V	86	146	55	5100	10021S	HM55

Note: 2 piece construction

1-1/2" SQUARE DRIVE

ACCESSORIES

Universal Joint



SIZE in	PART#	RET RING
1-1/2	U2424	10020S

Adapters

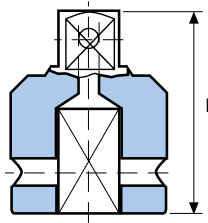

PART#	FEMALE in	MALE in	L in	RET RING
A2416	1-1/2	1	3.75	10020S
A2440	1-1/2	2-1/2	3.50	10020S
A2495	1-1/2	#5 Spline	4.33	10020S

Double Ended Female Adapters

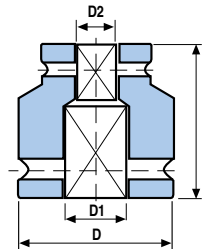

PART#	D1 in	D2 in	L in	D in	RET RINGS (D1) (D2)
AN2416	1-1/2	1	3.27	3.39	10020S 10008S
AN2424	1-1/2	1-1/2	3.35	3.39	10020S 10020S
AN4024	2-1/2	1-1/2	4.53	5.00	10035S 10020S

Double Ended Male Extensions

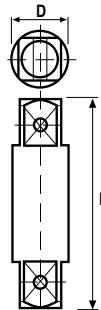

PART#	D in	L in
Z2404	1.93	4
Z2405	1.93	5
Z2410	1.93	10
Z2420	1.93	20

Extensions

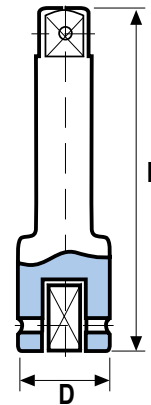

PART#	D in	L in	RET RING
E2406	3.385	6	10020S
E2412	3.385	12	10020S

Retaining Pins and Rings

SQUARE DRIVE	SOCKET SIZES	PIN#	RING#	d in	L in	D in
1-1/2	Up To 3-9/16" (90mm)	P2486	R2486	.234	2.925	2.925
1-1/2	Above 3-9/16" (90mm)	P24127	R24127	.234	4.525	4.525

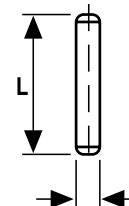
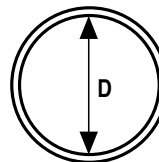

2-1/2" SQUARE DRIVE

SIX POINT IMPACT SOCKETS

Standard Fractional Sizes

SIZE in	PART#	D1 in	D2 in	L in	T in	C in
1-5/8	Z-4026	4.094	5.000	4.485	0.846	2.349
1-11/16	Z-4027	4.094	5.000	4.485	0.984	2.349
1-3/4	Z-4028	4.094	5.000	4.485	1.000	2.349
1-13/16	Z-4029	4.094	5.000	4.485	1.000	2.349
1-7/8	Z-4030	4.094	5.000	4.485	1.062	2.349
1-15/16	Z-4031	4.094	5.000	4.485	1.062	2.349
2	Z-4032	4.094	5.000	4.485	1.062	2.349
2-1/16	Z-4033	4.094	5.000	4.485	1.181	2.349
2-1/8	Z-4034	4.094	5.000	4.485	1.181	2.349
2-3/16	Z-4035	4.094	5.000	4.485	1.260	2.349
2-1/4	Z-4036	4.094	5.000	4.485	1.280	2.349
2-5/16	Z-4037	4.094	5.000	4.485	1.299	2.349
2-3/8	Z-4038	4.094	5.000	4.485	1.378	2.349
2-7/16	Z-4039	4.094	5.000	4.485	1.378	2.349
2-1/2	Z-4040	4.094	5.000	4.485	1.378	2.349
2-9/16	Z-4041	4.094	5.000	4.485	1.378	2.349
2-5/8	Z-4042	4.094	5.000	4.485	1.496	2.349
2-11/16	Z-4043	4.094	5.000	4.485	1.496	2.349
2-3/4	Z-4044	4.094	5.000	4.485	1.496	2.349
2-13/16	Z-4045	4.094	5.000	4.870	1.575	2.349
2-7/8	Z-4046	4.094	5.000	4.870	1.614	2.349
2-15/16	Z-4047	4.094	5.000	4.870	1.614	2.349
3	Z-4048	4.094	5.000	4.870	1.732	2.349
3-1/16	Z-4049	4.094	5.000	4.870	1.732	2.349
3-1/8	Z-4050	4.094	5.000	4.870	1.732	2.349
3-3/16	Z-4051	5.000	5.000	5.070	1.850	2.743
3-1/4	Z-4052	5.000	5.000	5.070	1.850	2.743
3-5/16	Z-4053	5.000	5.000	5.070	1.850	2.743
3-3/8	Z-4054	5.000	5.000	5.070	1.930	2.743
3-7/16	Z-4055	5.315	5.000	5.140	1.930	2.822
3-1/2	Z-4056	5.315	5.000	5.140	1.930	2.822
3-9/16	Z-4057	5.315	5.000	5.140	1.930	2.822
3-5/8	Z-4058	5.315	5.000	5.140	1.930	2.822
3-11/16	Z-4059	5.315	5.000	5.140	1.930	2.822
3-3/4	Z-4060	5.512	5.000	5.140	1.930	2.822
3-13/16	Z-4061	5.709	5.000	5.500	2.125	3.137
3-7/8	Z-4062	5.709	5.000	5.500	2.125	3.137
3-15/16	Z-4063	5.709	5.000	5.500	2.125	3.137
4	Z-4064	5.906	5.000	5.500	2.125	3.137
4-1/16	Z-4065	5.906	5.000	5.500	2.125	3.137
4-1/8	Z-4066	6.102	5.000	5.500	2.125	3.137
4-3/16	Z-4067	6.102	5.000	5.850	2.440	3.491
4-1/4	Z-4068	6.102	5.000	5.850	2.440	3.491

Standard Fractional Sizes Cont.

SIZE in	PART#	D1 in	D2 in	L in	T in	C in
4-5/16	Z-4069	6.299	5.000	5.850	2.440	3.49
4-3/8	Z-4070	6.299	5.000	5.850	2.440	3.491
4-7/16	Z-4071	6.496	5.000	5.850	2.440	3.49
4-1/2	Z-4072	6.496	5.000	5.850	2.440	3.491
4-5/8	Z-4074	6.693	5.000	6.160	2.640	3.806
4-3/4	Z-4076	6.693	5.000	6.160	2.640	3.806
4-7/8	Z-4078	6.693	5.000	6.160	2.640	3.806
5	Z-4080	7.087	5.000	6.435	2.830	4.121
5-1/8	Z-4082	7.087	5.000	6.430	2.990	4.436
5-3/16	Z-4083	7.087	5.000	6.780	2.909	4.436
5-1/4	Z-4084	7.480	5.000	6.780	2.99	4.436
5-3/8	Z-4086	7.480	5.000	6.780	2.99	4.436
5-1/2	Z-4088	7.480	5.000	6.860	3.11	4.790
5-5/8	Z-4090	7.874	5.906	7.090	3.27	4.790
5-3/4	Z-4092	7.874	5.906	7.090	3.27	4.790
5-7/8	Z-4094	8.268	5.906	7.410	3.46	5.105
6	Z-4096	8.268	5.906	7.410	3.46	5.105
6-1/8	Z-4098	8.268	5.906	7.410	3.46	5.105
6-1/4	Z-40100	8.661	5.906	7.560	3.58	5.263
6-3/8	Z-40102	8.661	5.906	7.560	3.58	5.263
6-1/2	Z-40104	9.055	6.890	7.830	3.70	5.735
6-5/8	Z-40106	9.055	6.890	7.830	3.70	5.735
6-3/4	Z-40108	9.055	6.890	8.110	3.90	5.735
6-7/8	Z-40110	9.449	6.890	8.110	3.90	5.735
7	Z-40112	9.449	6.890	8.340	4.09	6.050
7-1/8	Z-40114	9.843	6.890	8.340	4.09	6.050
7-1/4	Z-40116	9.843	6.890	8.340	4.09	6.050
7-3/8	Z-40118	9.843	6.890	8.500	4.21	6.208
7-1/2	Z-40120	10.236	6.890	8.500	4.21	6.208
7-5/8	Z-40122	10.236	6.890	8.650	4.29	6.365
7-3/4	Z-40124	10.630	6.890	8.810	4.41	6.523
7-13/16	Z-40125	10.630	6.890	8.810	4.41	6.523
7-7/8	Z-40126	10.630	6.890	8.810	4.41	6.523
8	Z-40128	10.630	6.890	9.040	4.53	7.034
8-1/8	Z-40130	11.024	6.890	9.040	4.53	7.034
8-1/4	Z-40132	11.024	6.890	9.040	4.53	7.034
8-3/8	Z-40134	11.417	6.890	9.320	4.72	7.034
8-1/2	Z-40136	11.417	6.890	9.750	4.80	7.782
8-3/4	Z-40140	11.811	6.890	9.870	4.88	7.782
8-7/8	Z-40142	11.811	6.890	10.062	4.96	7.782
9	Z-40144	12.205	6.890	10.062	5.04	7.782
9-1/8	Z-40146	12.205	6.890	10.062	5.16	7.782
9-1/4	Z-40148	12.205	6.890	10.725	5.24	9.515

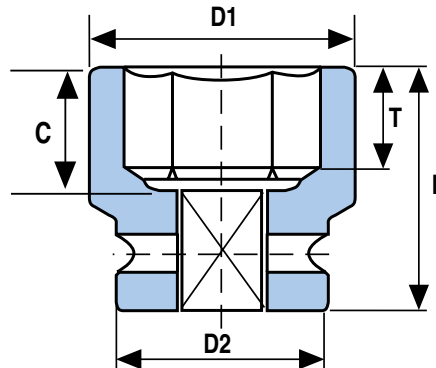

2-1/2" SQUARE DRIVE

SIX POINT IMPACT SOCKETS

Deep Fractional Sizes

SIZE in	PART#	D1 in	D2 in	L in	T in	C in
1-5/8	Z-4026L	4.094	5.000	7.480	0.846	5.184
1-11/16	Z-4027L	4.094	5.000	7.480	0.984	5.184
1-3/4	Z-4028L	4.094	5.000	7.480	1.000	5.184
1-13/16	Z-4029L	4.094	5.000	7.480	1.000	5.184
1-7/8	Z-4030L	4.094	5.000	7.480	1.062	5.184
1-15/16	Z-4031L	4.094	5.000	7.480	1.062	5.184
2	Z-4032L	4.094	5.000	7.480	1.062	5.184
2-1/16	Z-4033L	4.094	5.000	7.480	1.181	5.184
2-1/8	Z-4034L	4.094	5.000	7.480	1.181	5.184
2-3/16	Z-4035L	4.094	5.000	7.480	1.260	5.184
2-1/4	Z-4036L	4.094	5.000	7.480	1.280	5.184
2-5/16	Z-4037L	4.094	5.000	7.480	1.299	5.184
2-3/8	Z-4038L	4.094	5.000	7.480	1.378	5.184
2-7/16	Z-4039L	4.094	5.000	7.480	1.378	5.184
2-1/2	Z-4040L	4.094	5.000	7.480	1.378	5.184
2-9/16	Z-4041L	4.094	5.000	7.480	1.378	5.184
2-5/8	Z-4042L	4.094	5.000	7.480	1.496	5.184
2-11/16	Z-4043L	4.094	5.000	7.480	1.496	5.184
2-3/4	Z-4044L	4.094	5.000	7.480	1.496	5.184
2-13/16	Z-4045L	4.094	5.000	7.480	1.575	5.184
2-7/8	Z-4046L	4.094	5.000	7.480	1.614	5.184
2-15/16	Z-4047L	4.094	5.000	7.480	1.614	5.184
3	Z-4048L	4.094	5.000	7.480	1.732	5.184
3-1/16	Z-4049L	4.094	5.000	7.480	1.732	5.184
3-1/8	Z-4050L	4.094	5.000	7.480	1.732	5.184
3-3/16	Z-4051L	5.000	5.000	7.480	1.850	5.184
3-1/4	Z-4052L	5.000	5.000	7.480	1.850	5.184
3-5/16	Z-4053L	5.000	5.000	7.480	1.850	5.184
3-3/8	Z-4054L	5.000	5.000	7.480	1.930	5.184
3-7/16	Z-4055L	5.315	5.000	7.480	1.930	5.184
3-1/2	Z-4056L	5.315	5.000	7.480	1.930	5.184
3-9/16	Z-4057L	5.315	5.000	7.480	1.930	5.184
3-5/8	Z-4058L	5.315	5.000	7.480	1.930	5.184
3-11/16	Z-4059L	5.315	5.000	7.480	1.930	5.184
3-3/4	Z-4060L	5.512	5.000	7.480	1.930	5.184
3-13/16	Z-4061L	5.709	5.000	7.720	2.125	5.420
3-7/8	Z-4062L	5.709	5.000	7.720	2.125	5.420
3-15/16	Z-4063L	5.709	5.000	7.720	2.125	5.420
4	Z-4064L	5.906	5.000	7.720	2.125	5.420
4-1/16	Z-4065L	5.906	5.000	7.720	2.125	5.420
4-1/8	Z-4066L	6.102	5.000	7.720	2.125	5.420
4-3/16	Z-4067L	6.102	5.000	8.070	2.440	5.775
4-1/4	Z-4068L	6.102	5.000	8.070	2.440	5.775

Deep Fractional Sizes Cont.

SIZE in	PART#	D1 in	D2 in	L in	T in	C in
4-5/16	Z-4069L	6.299	5.000	8.070	2.44	5.775
4-3/8	Z-4070L	6.299	5.000	8.070	2.44	5.775
4-7/16	Z-4071L	6.496	5.000	8.070	2.44	5.775
4-1/2	Z-4072L	6.496	5.000	8.070	2.44	5.775
4-5/8	Z-4074L	6.693	5.000	8.380	2.64	6.090
4-3/4	Z-4076L	6.693	5.000	8.380	2.64	6.090
4-7/8	Z-4078L	6.693	5.000	8.380	2.64	6.090
5	Z-4080L	7.087	5.000	8.700	2.83	6.405
5-1/8	Z-4082L	7.087	5.000	9.000	2.99	6.719
5-3/16	Z-4083L	7.087	5.000	9.000	2.99	6.719
5-1/4	Z-4084L	7.480	5.000	9.000	2.99	6.719
5-3/8	Z-4086L	7.480	5.000	9.000	2.99	6.719
5-1/2	Z-4088L	7.480	5.000	9.120	3.110	7.074
5-5/8	Z-4090L	7.874	5.906	9.360	3.270	7.074
5-3/4	Z-4092L	7.874	5.906	9.360	3.270	7.074
5-7/8	Z-4094L	8.268	5.906	9.670	3.460	7.389
6	Z-4096L	8.268	5.906	9.670	3.460	7.389
6-1/8	Z-4098L	8.268	5.906	9.670	3.460	7.389
6-1/4	Z-40100L	8.661	5.906	9.820	3.580	7.546
6-3/8	Z-40102L	8.661	5.906	9.820	3.580	7.546
6-1/2	Z-40104L	9.055	6.890	10.140	3.700	8.019
6-5/8	Z-40106L	9.055	6.890	10.140	3.700	8.019
6-3/4	Z-40108L	9.055	6.890	10.300	3.900	8.019
6-7/8	Z-40110L	9.449	6.890	10.300	3.900	8.019
7	Z-40112L	9.449	6.890	10.600	4.090	8.334
7-1/8	Z-40114L	9.843	6.890	10.600	4.090	8.334
7-1/4	Z-40116L	9.843	6.890	10.600	4.090	8.334
7-3/8	Z-40118L	9.843	6.890	10.760	4.210	8.491
7-1/2	Z-40120L	10.236	6.890	10.760	4.210	8.491
7-5/8	Z-40122L	10.236	6.890	10.920	4.290	8.649
7-3/4	Z-40124L	10.630	6.890	10.070	4.410	8.806
7-13/16	Z-40125L	10.630	6.890	10.070	4.410	8.806
7-7/8	Z-40126L	10.630	6.890	10.070	4.410	8.806
8	Z-40128L	10.630	6.890	11.310	4.530	9.318
8-1/8	Z-40130L	11.024	6.890	11.310	4.530	9.318
8-1/4	Z-40132L	11.024	6.890	11.310	4.530	9.318
8-3/8	Z-40134L	11.417	6.890	11.580	4.720	9.318
8-1/2	Z-40136L	11.417	6.890	12.320	4.800	10.066
8-3/4	Z-40140L	11.811	6.890	12.320	4.880	10.066
8-7/8	Z-40142L	11.811	6.890	12.320	4.960	10.066
9	Z-40144L	12.205	6.890	12.320	5.040	10.066
9-1/8	Z-40146L	12.205	6.890	12.320	5.160	10.066
9-1/4	Z-40148L	12.205	6.890	12.980	5.240	11.798

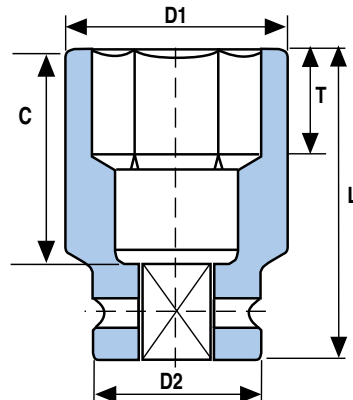

Standard Metric Sizes

SIZE mm	PART#	D1 mm	D2 mm	L mm	T mm	C mm
41	Z-40M41	104	127	115	21.5	60
42	Z-40M42	104	127	115	21.5	60
43	Z-40M43	104	127	115	25	60
44	Z-40M44	104	127	115	21.5	60
45	Z-40M45	104	127	115	21.5	60
46	Z-40M46	104	127	115	25.5	60
47	Z-40M47	104	127	115	23.5	60
48	Z-40M48	104	127	115	23.5	60
49	Z-40M49	104	127	115	27	60
50	Z-40M50	104	127	115	23.5	60
51	Z-40M51	104	127	115	27	60
52	Z-40M52	104	127	115	27	60
54	Z-40M54	104	127	115	30	60
55	Z-40M55	104	127	115	27	60
56	Z-40M56	104	127	115	28	60
57	Z-40M57	104	127	115	32.5	60
58	Z-40M58	104	127	115	28	60
59	Z-40M59	104	127	115	33	60
60	Z-40M60	104	127	115	28	60
61	Z-40M61	104	127	115	28	60
62	Z-40M62	104	127	115	35	60
65	Z-40M65	104	127	115	35	60
67	Z-40M67	104	127	115	38	60
70	Z-40M70	104	127	115	38	60
73	Z-40M73	115	127	125	41	70
75	Z-40M75	115	127	125	41	70
76	Z-40M76	115	127	125	44	70
80	Z-40M80	115	127	125	37	70
85	Z-40M85	127	127	130	40	75
86	Z-40M86	127	127	130	49	75
90	Z-40M90	135	127	132	43	77
95	Z-40M95	140	127	132	49	77
100	Z-40M100	145	127	141	54	86
105	Z-40M105	150	127	141	54	86
110	Z-40M110	160	127	150	62	95
115	Z-40M115	165	127	158	57	103
120	Z-40M120	170	127	158	67	103
125	Z-40M125	170	127	158	67	103
130	Z-40M130	180	127	174	76	119
135	Z-40M135	190	127	174	76	119
140	Z-40M140	190	127	176	79	121
145	Z-40M145	200	150	182	83	127
150	Z-40M150	210	150	190	88	135
155	Z-40M155	210	150	190	88	135
160	Z-40M160	220	150	194	91	139
165	Z-40M165	230	175	201	94	146
170	Z-40M170	230	175	201	94	146
175	Z-40M175	240	175	208	99	153
180	Z-40M180	240	175	214	104	159
185	Z-40M185	250	175	214	104	159
190	Z-40M190	260	175	218	107	163
195	Z-40M195	260	175	222	109	167
200	Z-40M200	270	175	226	112	171
210	Z-40M210	280	175	232	115	177
215	Z-40M215	290	175	239	120	184
225	Z-40M225	300	175	258	126	203
235	Z-40M235	310	175	275	131	220

Deep Metric Sizes

SIZE mm	PART#	D1 mm	D2 mm	L mm	T mm	C mm
41	Z-40M41L	104	127	192	21.5	132
42	Z-40M42L	104	127	192	21.5	132
43	Z-40M43L	104	127	192	25	132
44	Z-40M44L	104	127	192	21.5	132
45	Z-40M45L	104	127	192	21.5	132
46	Z-40M46L	104	127	192	25.5	132
47	Z-40M47L	104	127	192	23.5	132
48	Z-40M48L	104	127	192	23.5	132
49	Z-40M49L	104	127	192	27	132
50	Z-40M50L	104	127	192	23.5	132
51	Z-40M51L	104	127	192	27	132
52	Z-40M52L	104	127	192	27	132
54	Z-40M54L	104	127	192	30	132
55	Z-40M55L	104	127	192	27	132
56	Z-40M56L	104	127	192	28	132
57	Z-40M57L	104	127	192	32.5	132
58	Z-40M58L	104	127	192	28	132
59	Z-40M59L	104	127	192	33	132
60	Z-40M60L	104	127	192	28	132
61	Z-40M61L	104	127	192	28	132
62	Z-40M62L	104	127	192	35	132
65	Z-40M65L	104	127	192	35	132
67	Z-40M67L	104	127	192	38	132
70	Z-40M70L	104	127	192	38	132
73	Z-40M73L	115	127	192	41	132
75	Z-40M75L	115	127	192	41	132
76	Z-40M76L	115	127	192	44	132
80	Z-40M80L	115	127	192	37	132
85	Z-40M85L	127	127	192	40	132
86	Z-40M86L	127	127	192	49	132
90	Z-40M90L	135	127	192	43	132
95	Z-40M95L	140	127	192	49	132
100	Z-40M100L	145	127	198	54	138
105	Z-40M105L	150	127	198	54	138
110	Z-40M110L	160	127	207	62	147
115	Z-40M115L	165	127	207	57	147
120	Z-40M120L	170	127	215	67	155
125	Z-40M125L	170	127	215	67	155
130	Z-40M130L	180	127	223	76	163
135	Z-40M135L	190	127	231	76	151
140	Z-40M140L	190	127	234	79	174
145	Z-40M145L	200	150	240	83	180
150	Z-40M150L	210	150	248	88	188
155	Z-40M155L	210	150	248	88	188
160	Z-40M160L	220	150	252	91	192
165	Z-40M165L	230	175	260	94	200
170	Z-40M170L	230	175	260	94	200
175	Z-40M175L	240	175	264	99	204
180	Z-40M180L	240	175	272	104	212
185	Z-40M185L	250	175	272	104	212
190	Z-40M190L	260	175	276	107	216
195	Z-40M195L	260	175	280	109	220
200	Z-40M200L	270	175	284	112	224
210	Z-40M210L	280	175	290	115	230
215	Z-40M215L	290	175	316	120	256
225	Z-40M225L	300	175	316	126	256
235	Z-40M235L	310	175	333	131	273

No one offers a broader line of 2-1/2" drive sockets than OZAT for the heaviest bolting applications in construction, plant maintenance, power generation, shipbuilding and refining.

OZAT sockets prove their value. They are guaranteed for hydraulic bolting jobs as well as for large impact wrenches. OZAT has a socket to exactly match your application. If not available from our standard product range, we'll custom design one for you (see page 83).

Adapters

PART#	FEMALE in	MALE in	L in
A4024	2-1/2	1-1/2	5.380
A4056	2-1/2	3-1/2	5.538

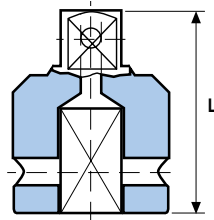

Double Ended Female Adapters

PART#	D1 in	D2 in	L in	D in
AN4024	2-1/2	1-1/2	4.53	5.00
AN4040	2-1/2	2-1/2	4.61	5.00
AN5640	3-1/2	2-1/2	6.34	6.89

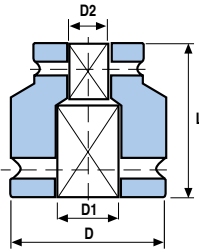

Double Ended Male Extensions

PART#	D in	L in
Z4005	3.31	5
Z4006	3.31	6
Z4008	3.31	8
Z4010	3.31	10
Z4015	3.31	15
Z4020	3.31	20
Z4026	3.31	26

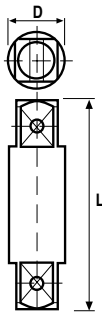

Universal Joint

SIZE in	PART#
2-1/2	U4040



Retaining Pins and Rings

SQUARE DRIVE	SOCKET SIZES	PIN#	RING#	d in	L in	D in
2-1/2	Up To 5-1/2" (140mm)	P40127	R40127	.312	4.290	4.446
2-1/2	From 5-1/2" (140mm) To 6-3/8" (160mm)	P40150	R40150	.312	5.187	5.309
2-1/2	Above 6-3/8" (160mm)	P40175	R40175	.312	6.162	6.318

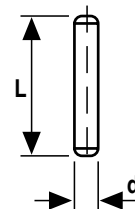
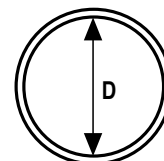

3-1/2" SQUARE DRIVE

SIX POINT IMPACT SOCKETS

Standard Fractional Sizes

SIZE in	PART#	D1 in	D2 in	L in	T in	C in
3-7/8	Z-5662	6.890	6.890	6.435	2.125	3.371
3-15/16	Z-5663	6.890	6.890	6.435	2.125	3.725
4	Z-5664	6.890	6.890	6.435	2.125	3.725
4-1/16	Z-5665	6.890	6.890	6.435	2.125	3.725
4-1/8	Z-5666	6.890	6.890	6.435	2.125	3.725
4-3/16	Z-5667	6.890	6.890	6.786	2.440	3.725
4-1/4	Z-5668	6.890	6.890	6.786	2.440	3.725
4-5/16	Z-5669	6.890	6.890	6.786	2.440	4.040
4-3/8	Z-5670	6.890	6.890	6.786	2.440	4.040
4-7/16	Z-5671	6.890	6.890	6.786	2.440	4.040
4-1/2	Z-5672	6.890	6.890	6.786	2.440	4.040
4-5/8	Z-5674	6.890	6.890	7.100	2.640	4.040
4-3/4	Z-5676	6.890	6.890	7.100	2.640	4.355
4-7/8	Z-5678	6.890	6.890	7.100	2.640	4.355
5	Z-5680	7.480	6.890	7.722	2.830	4.355
5-1/8	Z-5682	7.480	6.890	7.722	3.000	4.355
5-3/16	Z-5683	7.480	6.890	7.722	3.000	4.670
5-1/4	Z-5684	7.480	6.890	7.722	3.000	4.670
5-3/8	Z-5686	7.874	6.890	7.722	3.000	4.670
5-1/2	Z-5688	7.874	6.890	8.000	3.110	5.300
5-5/8	Z-5690	8.268	6.890	8.270	3.270	5.300
5-3/4	Z-5692	8.268	6.890	8.270	3.270	5.300
5-7/8	Z-5694	8.268	6.890	8.270	3.460	5.300
6	Z-5696	8.661	6.890	8.350	3.460	5.300
6-1/8	Z-5698	8.661	6.890	8.350	3.460	5.300
6-1/4	Z-56100	9.055	6.890	8.500	3.580	5.458
6-3/8	Z-56102	9.055	6.890	8.500	3.580	5.458
6-1/2	Z-56104	9.055	6.890	8.970	3.700	5.930
6-5/8	Z-56106	9.449	6.890	8.970	3.700	5.930
6-3/4	Z-56108	9.449	6.890	8.970	3.900	5.930
6-7/8	Z-56110	9.843	6.890	8.970	3.900	5.930
7	Z-56112	9.843	6.890	9.250	4.090	6.206
7-1/8	Z-56114	9.843	6.890	9.250	4.090	6.206
7-1/4	Z-56116	10.236	6.890	9.250	4.090	6.206
7-3/8	Z-56118	10.236	6.890	9.438	4.210	6.363
7-1/2	Z-56120	10.630	6.890	9.438	4.210	6.363
7-5/8	Z-56122	10.630	6.890	9.600	4.290	6.521
7-3/4	Z-56124	10.630	6.890	9.710	4.410	6.678
7-13/16	Z-56125	11.024	6.890	9.710	4.410	6.678
7-7/8	Z-56126	11.024	6.890	9.710	4.410	6.678
8	Z-56128	11.024	6.890	10.000	4.530	7.229
8-1/8	Z-56130	11.417	6.890	10.000	4.530	7.229
8-1/4	Z-56132	11.417	6.890	10.000	4.530	7.229
8-3/8	Z-56134	11.417	6.890	10.250	4.720	7.229
8-1/2	Z-56136	11.811	6.890	10.410	4.800	7.859
8-3/4	Z-56140	12.205	6.890	10.530	4.880	7.859
8-7/8	Z-56142	12.205	6.890	10.640	4.960	7.859
9	Z-56144	12.205	6.890	10.760	5.040	7.859
9-1/8	Z-56146	12.598	6.890	10.880	5.160	7.859
9-1/4	Z-56148	12.598	6.890	11.110	5.240	9.198

Deep Fractional Sizes

SIZE in	PART#	D1 in	D2 in	L in	T in	C in
3-7/8	Z-5662L	6.890	6.890	10.800	2.125	7.781
3-15/16	Z-5663L	6.890	6.890	10.800	2.125	7.781
4	Z-5664L	6.890	6.890	10.800	2.125	7.781
4-1/16	Z-5665L	6.890	6.890	10.800	2.125	7.781
4-1/8	Z-5666L	6.890	6.890	10.800	2.125	7.781
4-3/16	Z-5667L	6.890	6.890	10.800	2.440	7.781
4-1/4	Z-5668L	6.890	6.890	10.800	2.440	7.781
4-5/16	Z-5669L	6.890	6.890	10.800	2.440	7.781
4-3/8	Z-5670L	6.890	6.890	10.800	2.440	7.781
4-7/16	Z-5671L	6.890	6.890	10.800	2.440	7.781
4-1/2	Z-5672L	6.890	6.890	10.800	2.440	7.781
4-5/8	Z-5674L	6.890	6.890	10.800	2.640	7.781
4-3/4	Z-5676L	6.890	6.890	10.800	2.640	7.781
4-7/8	Z-5678L	6.890	6.890	10.800	2.640	7.781
5	Z-5680L	7.480	6.890	10.800	2.830	7.781
5-1/8	Z-5682L	7.480	6.890	10.920	3.000	7.781
5-3/16	Z-5683L	7.480	6.890	10.920	3.000	7.899
5-1/4	Z-5684L	7.480	6.890	10.920	3.000	7.899
5-3/8	Z-5686L	7.874	6.890	10.920	3.000	7.899
5-1/2	Z-5688L	7.874	6.890	11.230	3.110	8.568
5-5/8	Z-5690L	8.268	6.890	11.500	3.270	8.568
5-3/4	Z-5692L	8.268	6.890	11.500	3.270	8.568
5-7/8	Z-5694L	8.268	6.890	11.500	3.460	8.568
6	Z-5696L	8.661	6.890	11.580	3.460	8.568
6-1/8	Z-5698L	8.661	6.890	11.580	3.460	8.568
6-1/4	Z-56100L	9.055	6.890	11.740	3.580	8.725
6-3/8	Z-56102L	9.055	6.890	11.740	3.580	8.725
6-1/2	Z-56104L	9.055	6.890	12.220	3.700	9.198
6-5/8	Z-56106L	9.449	6.890	12.220	3.700	9.198
6-3/4	Z-56108L	9.449	6.890	12.220	3.900	9.198
6-7/8	Z-56110L	9.843	6.890	12.220	3.900	9.198
7	Z-56112L	9.843	6.890	12.480	4.090	9.473
7-1/8	Z-56114L	9.843	6.890	12.480	4.090	9.473
7-1/4	Z-56116L	10.236	6.890	12.480	4.090	9.473
7-3/8	Z-56118L	10.236	6.890	12.630	4.210	9.631
7-1/2	Z-56120L	10.630	6.890	12.630	4.210	9.631
7-5/8	Z-56122L	10.630	6.890	12.800	4.290	9.788
7-3/4	Z-56124L	10.630	6.890	12.950	4.410	9.946
7-13/16	Z-56125L	11.024	6.890	12.950	4.410	9.946
7-7/8	Z-56126L	11.024	6.890	12.950	4.410	9.946
8	Z-56128L	11.024	6.890	13.220	4.530	10.497
8-1/8	Z-56130L	11.417	6.890	13.220	4.530	10.497
8-1/4	Z-56132L	11.417	6.890	13.220	4.530	10.497
8-3/8	Z-56134L	11.417	6.890	13.500	4.720	10.497
8-1/2	Z-56136L	11.811	6.890	13.650	4.800	11.127
8-3/4	Z-56140L	12.205	6.890	13.800	4.880	11.127
8-7/8	Z-56142L	12.205	6.890	13.920	4.960	11.127
9	Z-56144L	12.205	6.890	14.000	5.040	11.127
9-1/8	Z-56146L	12.598	6.890	14.110	5.160	11.127
9-1/4	Z-56148L	12.598	6.890	14.430	5.240	12.426

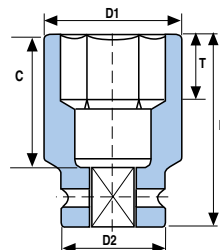
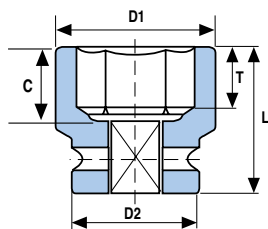

3-1/2" SQUARE DRIVE

SIX POINT IMPACT SOCKETS

Standard Metric Sizes

SIZE mm	PART#	D1 mm	D2 mm	L mm	T mm	C mm
100	Z-56M100	175	175	165	54	95
105	Z-56M105	175	175	165	54	94
110	Z-56M110	175	175	174	62	103
115	Z-56M115	175	175	174	57	103
120	Z-56M120	175	175	182	67	111
125	Z-56M125	175	175	182	67	111
130	Z-56M130	190	175	198	76	111
135	Z-56M135	190	175	198	76	119
140	Z-56M140	200	175	205	79	135
145	Z-56M145	210	175	212	83	135
150	Z-56M150	210	175	212	88	135
155	Z-56M155	220	175	214	88	135
160	Z-56M160	220	175	218	91	139
165	Z-56M165	230	175	230	94	151
170	Z-56M170	240	175	230	94	151
175	Z-56M175	250	175	230	99	151
180	Z-56M180	250	175	237	104	158
185	Z-56M185	260	175	237	104	158
190	Z-56M190	260	175	242	107	162
195	Z-56M195	270	175	246	109	166
200	Z-56M200	280	175	249	112	170
210	Z-56M210	290	175	256	115	184
215	Z-56M215	300	175	263	120	220
225	Z-56M225	310	175	273	126	200
230	Z-56M230	310	175	276	128	200
235	Z-56M235	320	175	279	131	200

Deep Metric Sizes

SIZE mm	PART#	D1 mm	D2 mm	L mm	T mm	C mm
100	Z-56M100L	175	175	277	54	198
105	Z-56M105L	175	175	277	54	198
110	Z-56M110L	175	175	277	62	198
115	Z-56M115L	175	175	277	57	198
120	Z-56M120L	175	175	277	67	198
125	Z-56M125L	175	175	277	67	198
130	Z-56M130L	190	175	280	76	198
135	Z-56M135L	190	175	280	76	201
140	Z-56M140L	200	175	288	79	218
145	Z-56M145L	210	175	295	83	218
150	Z-56M150L	210	175	295	88	218
155	Z-56M155L	220	175	297	88	218
160	Z-56M160L	220	175	301	91	222
165	Z-56M165L	230	175	313	94	234
170	Z-56M170L	240	175	313	94	234
175	Z-56M175L	250	175	313	99	234
180	Z-56M180L	250	175	320	104	241
185	Z-56M185L	260	175	320	104	241
190	Z-56M190L	260	175	324	107	245
195	Z-56M195L	270	175	328	109	249
200	Z-56M200L	280	175	332	112	253
210	Z-56M210L	290	175	339	115	267
215	Z-56M215L	300	175	346	120	283
225	Z-56M225L	310	175	357	126	283
230	Z-56M230L	310	175	359	128	283
235	Z-56M235L	320	175	362	131	283

ACCESSORIES

Adapters

PART#	FEMALE in	MALE in	L in
A5640	3-1/2	2-1/2	7.137

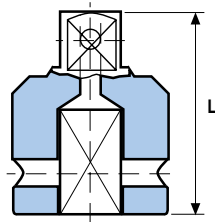

Double Ended Female Adapters

PART#	D1 in	D2 in	L in	D in
AN5640	3-1/2	2-1/2	6.34	6.89
AN5656	3-1/2	3-1/2	6.57	6.89

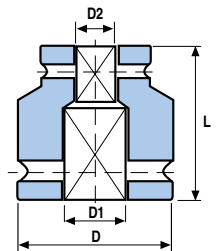

Double Ended Male Extensions

PART#	D in	L in
Z5610	4.685	10
Z5620	4.685	20
Z5640	4.685	40

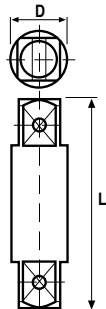

Retaining Pins and Rings

SQUARE DRIVE	SOCKET SIZES	PIN#	RING#	d in	L in	D in
3-1/2	All Sizes	P56175	R56175	0.39	6.24	6.24

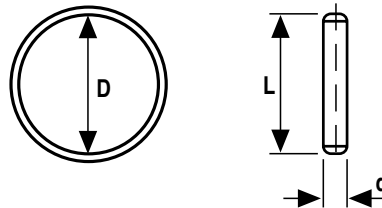

#5 SPLINE DRIVE

SIX POINT IMPACT SOCKETS

Standard Fractional Sizes

SIZE in	PART#	D1 in	D2 in	L in	T in	C in
3/4	Z-9512	1.890	2.362	2.730	.374	1.006
13/16	Z-9513	1.890	2.362	2.730	.435	1.006
7/8	Z-9514	1.890	2.362	2.730	.512	1.006
15/16	Z-9515	1.890	2.362	2.730	.512	1.006
1	Z-9516	1.929	2.362	2.730	.512	1.006
1-1/16	Z-9517	2.008	2.362	2.730	.512	1.006
1-1/8	Z-9518	2.008	2.362	2.730	.650	1.006
1-3/16	Z-9519	2.126	2.362	2.730	.650	1.006
1-1/4	Z-9520	2.362	2.362	2.925	.669	1.203
1-5/16	Z-9521	2.362	2.362	3.000	.748	1.281
1-3/8	Z-9522	2.362	2.362	3.000	.748	1.281
1-7/16	Z-9523	2.480	2.362	3.000	.748	1.281
1-1/2	Z-9524	2.480	2.362	3.125	.866	1.400
1-9/16	Z-9525	2.638	2.362	3.125	.866	1.400
1-5/8	Z-9526	2.638	2.362	3.125	.866	1.400
1-11/16	Z-9527	2.638	2.362	3.275	.984	1.557
1-3/4	Z-9528	2.874	2.362	3.275	1.000	1.557
1-13/16	Z-9529	2.874	2.362	3.275	1.000	1.577
1-7/8	Z-9530	2.874	2.362	3.432	1.063	1.715
1-15/16	Z-9531	2.874	2.362	3.432	1.063	1.715
2	Z-9532	3.228	2.362	3.432	1.063	1.715
2-1/16	Z-9533	3.228	3.386	3.625	1.181	1.911
2-1/8	Z-9534	3.228	3.386	3.625	1.181	1.911
2-3/16	Z-9535	3.228	3.386	3.740	1.260	2.030
2-1/4	Z-9536	3.465	3.386	3.740	1.299	2.030
2-5/16	Z-9537	3.465	3.386	3.740	1.299	2.030
2-3/8	Z-9538	3.465	3.386	3.822	1.378	2.108
2-7/16	Z-9539	3.465	3.386	3.900	1.378	2.108
2-1/2	Z-9540	3.937	3.386	3.900	1.378	2.108
2-9/16	Z-9541	3.937	3.386	3.900	1.378	2.108
2-5/8	Z-9542	3.937	3.386	3.978	1.496	2.266
2-11/16	Z-9543	3.937	3.386	3.978	1.496	2.266
2-3/4	Z-9544	3.937	3.386	3.978	1.496	2.266
2-13/16	Z-9545	4.134	3.386	4.210	1.575	2.502
2-7/8	Z-9546	4.134	3.386	4.210	1.614	2.502
2-15/16	Z-9547	4.134	3.386	4.210	1.614	2.502
3	Z-9548	4.291	3.386	4.446	1.732	2.738
3-1/16	Z-9549	4.291	3.386	4.446	1.732	2.738
3-1/8	Z-9550	4.291	3.386	4.446	1.732	2.738
3-1/4	Z-9552	5.062	3.386	4.909	2.106	2.781
3-5/16	Z-9553	5.062	3.386	4.909	2.106	2.781
3-3/8	Z-9554	5.062	3.386	4.909	2.106	2.781
3-1/2	Z-9556	5.129	3.386	4.909	2.106	2.781
3-5/8	Z-9558	5.256	3.386	4.909	2.106	2.781
3-3/4	Z-9560	5.309	3.386	4.909	2.106	2.781
3-7/8	Z-9562	5.442	3.386	4.909	2.106	2.781
4	Z-9564	5.511	3.386	4.909	2.106	2.781

Deep Fractional Sizes

SIZE in	PART#	D1 in	D2 in	L in	T in	C in
3/4	Z-9512L	1.890	2.362	6.240	.374	4.549
13/16	Z-9513L	1.890	2.362	6.240	.435	4.549
7/8	Z-9514L	1.890	2.362	6.240	.512	4.549
15/16	Z-9515L	1.890	2.362	6.240	.512	4.549
1	Z-9516L	1.929	2.362	6.240	.512	4.549
1-1/16	Z-9517L	2.008	2.362	6.240	.512	4.549
1-1/8	Z-9518L	2.008	2.362	6.240	.650	4.549
1-3/16	Z-9519L	2.126	2.362	6.240	.650	4.549
1-1/4	Z-9520L	2.362	2.362	6.240	.669	4.549
1-5/16	Z-9521L	2.362	2.362	6.240	.748	4.549
1-3/8	Z-9522L	2.362	2.362	6.240	.748	4.549
1-7/16	Z-9523L	2.480	2.362	6.240	.748	4.549
1-1/2	Z-9524L	2.480	2.362	6.240	.866	4.549
1-9/16	Z-9525L	2.638	2.362	6.240	.866	4.549
1-5/8	Z-9526L	2.638	2.362	6.240	.866	4.549
1-11/16	Z-9527L	2.638	2.362	6.240	.984	4.549
1-3/4	Z-9528L	2.874	2.362	6.240	1.000	4.549
1-13/16	Z-9529L	2.874	2.362	6.240	1.000	4.549
1-7/8	Z-9530L	2.874	2.362	6.240	1.063	4.549
1-15/16	Z-9531L	2.874	2.362	6.240	1.063	4.549
2	Z-9532L	3.228	2.362	6.240	1.063	4.549
2-1/16	Z-9533L	3.228	3.386	6.240	1.181	4.549
2-1/8	Z-9534L	3.228	3.386	6.240	1.181	4.549
2-3/16	Z-9535L	3.228	3.386	6.240	1.260	4.549
2-1/4	Z-9536L	3.465	3.386	6.240	1.299	4.549
2-5/16	Z-9537L	3.465	3.386	6.240	1.299	4.549
2-3/8	Z-9538L	3.465	3.386	6.240	1.373	4.549
2-7/16	Z-9539L	3.465	3.386	6.240	1.378	4.549
2-1/2	Z-9540L	3.937	3.386	6.240	1.378	4.549
2-9/16	Z-9541L	3.937	3.386	6.240	1.378	4.549
2-5/8	Z-9542L	3.937	3.386	6.240	1.496	4.549
2-11/16	Z-9543L	3.937	3.386	6.240	1.496	4.549
2-3/4	Z-9544L	3.937	3.386	6.240	1.496	4.549
2-13/16	Z-9545L	4.134	3.386	6.240	1.575	4.549
2-7/8	Z-9546L	4.134	3.386	6.240	1.614	4.549
2-15/16	Z-9547L	4.134	3.386	6.240	1.614	4.549
3	Z-9548L	4.291	3.386	6.240	1.732	4.628
3-1/16	Z-9549L	4.291	3.386	6.310	1.732	4.628
3-1/8	Z-9550L	4.291	3.386	6.310	1.732	4.628

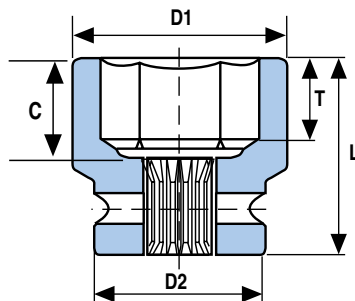

#5 SPLINE DRIVE

SIX POINT IMPACT SOCKETS

Standard Metric Sizes

SIZE mm	PART#	D1 mm	D2 mm	L mm	T mm	C mm
19	Z-95M19	48	60	70	.374	26
20	Z-95M20	48	60	70	.394	26
21	Z-95M21	48	60	70	.394	26
22	Z-95M22	48	60	70	.394	26
23	Z-95M23	48	60	70	.472	26
24	Z-95M24	49	60	70	.472	26
25	Z-95M25	49	60	70	.512	26
26	Z-95M26	51	60	70	.512	26
27	Z-95M27	51	60	70	.512	26
28	Z-95M28	51	60	70	.551	26
29	Z-95M29	54	60	70	.551	26
30	Z-95M30	54	60	70	.650	26
31	Z-95M31	60	60	75	.650	31
32	Z-95M32	60	60	75	.650	31
33	Z-95M33	60	60	75	.669	31
34	Z-95M34	60	60	77	.669	33
35	Z-95M35	60	60	77	.748	33
36	Z-95M36	63	60	77	.748	33
37	Z-95M37	63	60	77	.748	33
38	Z-95M38	63	60	80	.866	36
39	Z-95M39	67	60	80	.866	36
40	Z-95M40	67	60	80	.866	36
41	Z-95M41	67	60	80	.866	36
42	Z-95M42	67	60	80	.846	36
43	Z-95M43	67	60	84	.984	40
44	Z-95M44	73	60	84	.846	40
45	Z-95M45	73	60	84	.846	40
46	Z-95M46	73	60	84	1.004	40
47	Z-95M47	73	60	84	.925	40
48	Z-95M48	73	60	88	.925	44
49	Z-95M49	73	60	88	1.063	44
50	Z-95M50	82	60	88	.925	44
51	Z-95M51	82	60	88	1.063	44
52	Z-95M52	82	60	88	1.063	44
54	Z-95M54	82	60	93	1.181	49
55	Z-95M55	82	60	93	1.063	49
56	Z-95M56	88	86	96	1.102	52
57	Z-95M57	88	76	96	1.299	52
58	Z-95M58	88	86	96	1.102	52
59	Z-95M59	88	86	96	1.299	52
60	Z-95M60	88	86	96	1.102	52
61	Z-95M61	88	86	98	1.102	54
62	Z-95M62	88	86	100	1.378	56
65	Z-95M65	100	86	100	1.378	56
67	Z-95M67	100	86	102	1.496	58
70	Z-95M70	100	86	102	1.496	58
73	Z-95M73	105	86	108	1.614	64
75	Z-95M75	105	86	108	1.614	64
76	Z-95M76	109	86	114	1.732	70
80	Z-95M80	115	86	114	1.457	70

Deep Metric Sizes

SIZE mm	PART#	D1 mm	D2 mm	L mm	T mm	C mm
19	Z-95M19L	48	60	160	.374	116
20	Z-95M20L	48	60	160	.394	116
21	Z-95M21L	48	60	160	.394	116
22	Z-95M22L	48	60	160	.394	116
23	Z-95M23L	48	60	160	.472	116
24	Z-95M24L	49	60	160	.472	116
25	Z-95M25L	49	60	160	.512	116
26	Z-95M26L	51	60	160	.512	116
27	Z-95M27L	51	60	160	.512	116
28	Z-95M28L	51	60	160	.551	116
29	Z-95M29L	54	60	160	.551	116
30	Z-95M30L	54	60	160	.650	116
31	Z-95M31L	60	60	160	.650	116
32	Z-95M32L	60	60	160	.650	116
33	Z-95M33L	60	60	160	.669	116
34	Z-95M34L	60	60	160	.669	116
35	Z-95M35L	60	60	160	.748	116
36	Z-95M36L	63	60	160	.748	116
37	Z-95M37L	63	60	160	.748	116
38	Z-95M38L	63	60	160	.866	116
39	Z-95M39L	67	60	160	.866	116
40	Z-95M40L	67	60	160	.866	116
41	Z-95M41L	67	60	160	.866	116
42	Z-95M42L	67	60	160	.846	116
43	Z-95M43L	67	60	160	.984	116
44	Z-95M44L	73	60	160	.846	116
45	Z-95M45L	73	60	160	.846	116
46	Z-95M46L	73	60	160	1.004	116
47	Z-95M47L	73	60	160	.925	116
48	Z-95M48L	73	60	160	.925	116
49	Z-95M49L	73	60	160	1.063	116
50	Z-95M50L	82	60	160	.925	116
51	Z-95M51L	82	60	160	1.063	116
52	Z-95M52L	82	60	160	1.063	116
54	Z-95M54L	82	60	160	1.181	116
55	Z-95M55L	82	60	160	1.063	116
56	Z-95M56L	88	86	160	1.102	116
57	Z-95M57L	88	76	160	1.299	116
58	Z-95M58L	88	86	160	1.102	116
59	Z-95M59L	88	86	160	1.299	116
60	Z-95M60L	88	86	160	1.102	116
61	Z-95M61L	88	86	160	1.102	116
62	Z-95M62L	88	86	160	1.378	116
65	Z-95M65L	100	86	160	1.378	116
67	Z-95M67L	100	86	160	1.496	116
70	Z-95M70L	100	86	160	1.496	116
73	Z-95M73L	105	86	160	1.614	116
75	Z-95M75L	105	86	162	1.614	116
76	Z-95M76L	109	86	162	1.732	118
80	Z-95M80L	115	86	162	1.457	118

Budd Wheel Socket Sizes

SIZE	PART#	D1	D2	L	T
13/16 X 1-1/2	Z-9524BS	2.48	2.36	4.133	.571
13/16	Z-9513B	2.008	2.36	2.756	.472

#4 SPLINE DRIVE

SIX POINT IMPACT SOCKETS



Universal Joint

SIZE	PART#
#4 Spline Drive	U9494

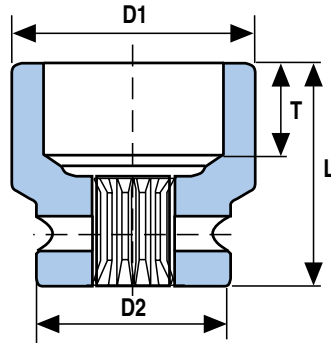

#4 Standard Length Fractional and Metric Sizes

SIZE in	SIZE mm	PART#	D1 mm	D2 mm	L mm	T mm
1-1/16	27	Z-9417M27	46	52	59	13
1-1/8		Z-9418	48	52	65	16.5
1 3/16	30	Z-9419M30	50	52	65	16.5
1-1/4		Z-9420	52	52	65	17
1-5/16		Z-9421	52	52	68	19
1 3/8	35	Z-9422M35	52	52	68	19
1-7/16		Z-9423	52	52	68	19
1-1/2	38	Z-9424M38	52	52	73	22
1-9/16		Z-9425	57	52	73	22
1-5/8	41	Z-9426M41	57	52	73	22
1-11/16		Z-9427	57	52	73	22
1-3/4		Z-9428	63	52	78	25.5
1-13/16		Z-9429	67	52	78	25.5
1-7/8		Z-9430	67	52	78	27
1-15/16		Z-9431	70	52	81	27
2		Z-9432	73	52	81	27
2-1/16		Z-9433	73	52	85	30
2-1/8		Z-9434	78	52	88	32
2-3/16		Z-9435	78	52	88	23
2-1/4		Z-9436	78	52	88	23

ACCESSORIES FOR #5 SPLINE DRIVE

Adapters

PART#	FEMALE in	MALE in	L in
A9516	#5	1"	3.54
A9524	#5	1-1/2"	3.94
A2495	1-1/2"	#5	5.43

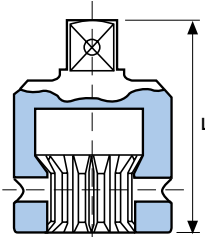

Extensions

PART#	L in
E9508	8
E9515	15

Universal Joint

SIZE	PART#
#5 Spline Drive	U9595



Universal Joint Repair Kits

PART#	DESCRIPTION
95UK1	Retainer Kit Contents: Hex Plunger, Lock Button, Inner & Outer Springs
95UK2	Pin Kit Contents: Drive Pin, Trunnions, Spiral Pins
95UK3	Retrofit Kit Contents: All Parts From the Above 2 Kits

Retaining Pins and Rings

SPLINE DRIVE	SOCKET SIZES	PIN#	RING#	d in	L in	D in
#5	Up To 2-3/16" (55mm)	P9560	R9560	.950	1.950	1.950
#5	Above 2-3/16" (55mm)	P9586	R9586	.950	2.964	2.964

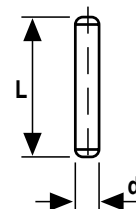
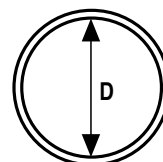

Fractional Sizes

PART#	SIZE in	D in	C in	L in
FSW14	7/8	1-13/16	9/16	6-1/2
FSW15	15/16	1-13/16	9/16	6-1/2
FSW16	1	1-13/16	9/16	6-1/2
FSW17	1-1/16	1-13/16	5/8	7-1/16
FSW18	1-1/8	1-13/16	5/8	7-1/16
FSW19	1-3/16	2-1/16	11/16	7-1/2
FSW20	1-1/4	2-1/16	11/16	7-1/2
FSW21	1-5/16	2-1/16	11/16	7-1/2
FSW22	1-3/8	2-1/16	11/16	7-1/2
FSW23	1-7/16	2-15/16	11/16	8-1/16
FSW24	1-1/2	2-15/16	11/16	8-1/16
FSW25	1-9/16	2-15/16	11/16	8-1/16
FSW26	1-5/8	2-15/16	13/16	9-1/16
FSW27	1-11/16	2-15/16	13/16	9-1/16
FSW28	1-3/4	2-15/16	13/16	9-1/16
FSW29	1-13/16	2-15/16	7/8	9-7/16
FSW30	1-7/8	2-15/16	7/8	9-7/16
FSW31	1-15/16	2-15/16	7/8	9-7/16
FSW32	2	3-1/8	15/16	10-1/16
FSW33	2-1/16	3-1/8	15/16	10-1/16
FSW34	2-1/8	3-1/8	15/16	10-1/16
FSW35	2-3/16	3-3/8	1	10-5/8
FSW36	2-1/4	3-3/8	1	10-5/8
FSW37	2-5/16	3-3/8	1	10-5/8
FSW38	2-3/8	3-11/16	1	11
FSW39	2-7/16	3-11/16	1	11
FSW40	2-1/2	3-11/16	1	11
FSW41	2-9/16	4	1-3/16	11-13/16
FSW42	2-5/8	4	1-3/16	11-13/16
FSW43	2-11/16	4	1-3/16	11-13/16
FSW44	2-3/4	4-5/16	1-5/16	13
FSW45	2-13/16	4-5/16	1-5/16	13
FSW46	2-7/8	4-5/16	1-5/16	13
FSW47	2-15/16	4-5/16	1-5/16	13
FSW48	3	4-5/16	1-5/16	13
FSW49	3-1/16	4-5/16	1-5/16	13
FSW50	3-1/8	4-15/16	1-7/16	14-3/16
FSW51	3-3/16	4-15/16	1-7/16	14-3/16
FSW52	3-1/4	4-15/16	1-7/16	14-3/16
FSW53	3-5/16	4-15/16	1-7/16	14-3/16
FSW54	3-3/8	4-15/16	1-7/16	14-3/16
FSW55	3-7/16	4-15/16	1-7/16	14-3/16
FSW56	3-1/2	4-15/16	1-7/16	14-3/16
FSW57	3-9/16	5-9/16	1-9/16	15-3/8
FSW58	3-5/8	5-9/16	1-9/16	15-3/8
FSW59	3-11/16	5-9/16	1-9/16	15-3/8
FSW60	3-3/4	5-9/16	1-9/16	15-3/8
FSW61	3-13/16	5-9/16	1-9/16	15-3/8
FSW62	3-7/8	5-9/16	1-9/16	15-3/8
FSW63	3-15/16	6-1/8	1-3/4	16-9/16
FSW64	4	6-1/8	1-3/4	16-9/16
FSW65	4-1/16	6-1/8	1-3/4	16-9/16
FSW66	4-1/8	6-1/8	1-3/4	16-9/16
FSW67	4-3/16	6-1/8	1-3/4	16-9/16
FSW68	4-1/4	6-1/8	1-3/4	16-9/16

Fractional Sizes Cont.

PART#	SIZE in	D in	C in	L in
FSW69	4-5/16	6-11/16	1-7/8	17-11/16
FSW70	4-3/8	6-11/16	1-7/8	17-11/16
FSW71	4-7/16	6-11/16	1-7/8	17-11/16
FSW72	4-1/2	6-11/16	1-7/8	17-11/16
FSW74	4-5/8	6-11/16	1-7/8	17-11/16
FSW76	4-3/4	7-3/16	2-1/8	18-7/8
FSW78	4-7/8	7-3/16	2-1/8	18-7/8
FSW80	5	7-3/16	2-1/8	18-7/8
FSW82	5-1/8	7-15/16	2-5/16	20-1/2
FSW83	5-3/16	7-15/16	2-5/16	20-1/2
FSW84	5-1/4	7-15/16	2-5/16	20-1/2
FSW86	5-3/8	7-15/16	2-5/16	20-1/2
FSW88	5-1/2	8-1/4	2-5/16	20-1/2
FSW90	5-5/8	8-1/4	2-5/16	20-1/2
FSW92	5-3/4	9	2-1/2	22-13/16
FSW94	5-7/8	9	2-1/2	22-13/16
FSW96	6	9	2-1/2	22-13/16
FSW98	6-1/8	9	2-1/2	22-13/16
FSW100	6-1/4	9	2-1/2	22-13/16
FSW102	6-3/8	9-7/16	2-1/2	22-13/16
FSW104	6-1/2	10-7/16	2-3/4	25-9/16
FSW106	6-5/8	10-7/16	2-3/4	25-9/16
FSW108	6-3/4	10-7/16	2-3/4	25-9/16
FSW110	6-7/8	10-7/16	2-3/4	25-9/16
FSW112	7	10-7/16	2-3/4	25-9/16
FSW114	7-1/8	10-7/16	2-3/4	25-9/16
FSW116	7-1/4	11-7/16	2-15/16	27-9/16
FSW118	7-3/8	11-7/16	2-15/16	27-9/16
FSW120	7-1/2	11-7/16	2-15/16	27-9/16
FSW122	7-5/8	11-7/16	2-15/16	27-9/16
FSW124	7-3/4	11-7/16	2-15/16	27-9/16
FSW125	7-13/16	11-7/16	2-15/16	27-9/16
FSW126	7-7/8	11-7/16	2-15/16	27-9/16
FSW128	8	11-7/16	2-15/16	27-9/16
FSW130	8-1/8	11-7/16	2-15/16	27-9/16
FSW132	8-1/4	12-5/8	3-1/8	29-1/2
FSW134	8-3/8	12-5/8	3-1/8	29-1/2
FSW136	8-1/2	12-5/8	3-1/8	29-1/2
FSW140	8-5/8	12-5/8	3-1/8	29-1/2
FSW142	8-7/8	12-5/8	3-1/8	29-1/2
FSW144	9	12-5/8	3-1/8	29-1/2

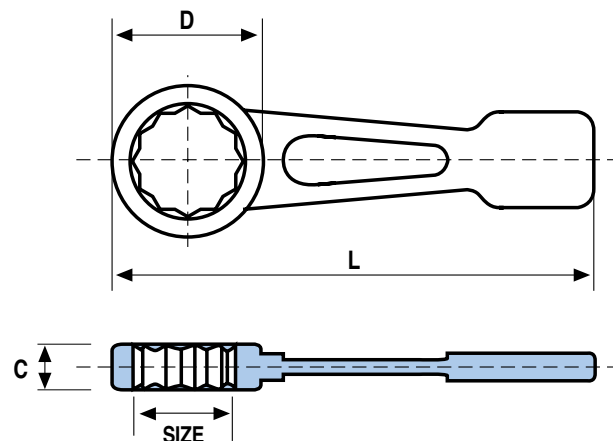

12 POINT OPENING

FLAT STRIKING WRENCHES

Metric Sizes

PART#	SIZE mm	D mm	C mm	L mm
FSWM22	22	43	15	165
FSWM23	23	43	15	165
FSWM24	24	43	15	165
FSWM25	25	43	15	165
FSWM26	26	43	15	165
FSWM27	27	46	16	180
FSWM28	28	46	16	180
FSWM29	29	46	16	180
FSWM30	30	52	17	190
FSWM31	31	52	17	190
FSWM32	32	52	17	190
FSWM33	33	52	17	190
FSWM34	34	52	17	190
FSWM35	35	52	17	190
FSWM36	36	58	18	205
FSWM37	37	58	18	205
FSWM38	38	58	18	205
FSWM39	39	58	18	205
FSWM40	40	58	18	205
FSWM41	41	66	20	230
FSWM42	42	66	20	230
FSWM43	43	66	20	230
FSWM44	44	66	20	230
FSWM45	45	66	20	230
FSWM46	46	74	22	240
FSWM47	47	74	22	240
FSWM48	48	74	22	240
FSWM49	49	74	22	240
FSWM50	50	80	24	255
FSWM51	51	80	24	255
FSWM52	52	80	24	255
FSWM54	54	80	24	255
FSWM55	55	86	25	270
FSWM56	56	86	25	270
FSWM57	57	86	25	270
FSWM58	58	86	25	270
FSWM59	59	86	25	270
FSWM60	60	93	26	280

Metric Sizes Cont.

PART#	SIZE mm	D mm	C mm	L mm
FSWM61	61	93	26	280
FSWM62	62	93	26	280
FSWM65	65	102	30	300
FSWM67	67	102	30	300
FSWM70	70	110	33	330
FSWM73	73	110	33	330
FSWM75	75	110	33	330
FSWM76	76	110	33	330
FSWM80	80	125	36	360
FSWM85	85	125	36	360
FSWM86	86	125	36	360
FSWM90	90	142	40	390
FSWM95	95	142	40	390
FSWM100	100	115	45	420
FSWM105	105	155	45	420
FSWM110	110	170	48	450
FSWM115	115	170	48	450
FSWM120	120	182	54	480
FSWM125	125	182	54	480
FSWM130	130	202	58	520
FSWM135	135	202	58	520
FSWM140	140	210	58	520
FSWM145	145	228	64	580
FSWM150	150	228	64	580
FSWM155	155	228	64	580
FSWM160	160	240	64	580
FSWM165	165	265	70	650
FSWM170	170	265	70	650
FSWM175	175	265	70	650
FSWM180	180	265	70	650
FSWM185	185	290	75	700
FSWM190	190	290	75	700
FSWM195	195	290	75	700
FSWM200	200	290	75	700
FSWM210	210	320	80	750
FSWM215	215	320	80	750
FSWM225	225	320	80	750
FSWM230	230	320	80	750



12 POINT OPENING

OFFSET STRIKING WRENCHES

FRACTIONAL SIZES

Part#	Size	D	C	L
SW16	1	2-3/64	53/64	11-31/32
SW17	1-1/16	2-3/64	53/64	11-31/32
SW18	1-1/8	2-3/64	53/64	11-31/32
SW20	1-1/4	2-3/64	53/64	11-31/32
SW21	1-5/16	2-3/64	53/64	11-31/32
SW23	1-7/16	2-23/64	1-1/16	12-23/64
SW24	1-1/2	2-19/32	1-1/16	12-23/64
SW26	1-5/8	2-19/32	1-1/16	12-23/64
SW27	1-11/16	2-19/32	1-1/16	12-23/64
SW28	1-3/4	2-19/32	1-1/16	12-23/64
SW29	1-13/16	2-19/32	1-1/16	12-23/64
SW30	1-7/8	3-5/64	1-17/64	14-7/8
SW31	1-15/16	3-5/64	1-17/64	14-7/8
SW32	2	3-5/64	1-17/64	14-7/8
SW34	2-1/8	3-5/64	1-17/64	14-7/8
SW35	2-3/16	3-5/64	1-17/64	14-7/8
SW36	2-1/4	4-21/64	1-21/32	15-63/64
SW37	2-5/16	4-21/64	1-21/32	15-63/64
SW38	2-3/8	4-21/64	1-21/32	15-63/64
SW40	2-1/2	4-21/64	1-21/32	15-63/64
SW41	2-9/16	4-21/64	1-21/32	15-63/64
SW42	2-5/8	4-21/64	1-21/32	15-63/64
SW44	2-3/4	4-21/64	1-21/32	15-63/64
SW46	2-7/8	4-21/64	1-21/32	15-63/64
SW47	2-15/16	4-21/64	1-21/32	15-63/64
SW48	3	4-21/64	1-21/32	15-63/64
SW50	3-1/8	5-1/8	2-11/64	17-23/32
SW54	3-3/8	5-1/8	2-11/64	17-23/32
SW56	3-1/2	5-1/8	2-11/64	17-23/32
SW60	3-3/4	6-7/64	2-9/16	19-11/16
SW62	3-7/8	6-7/64	2-9/16	19-11/16
SW66	4-1/8	6-7/64	2-9/16	19-11/16
SW68	4-1/4	6-7/64	2-9/16	19-11/16

ATP can manufacture specialized striking wrenches to suit your individual applications. Sizes larger than shown in the charts, open ended, short handled, six point, etc. are available on a special order basis.

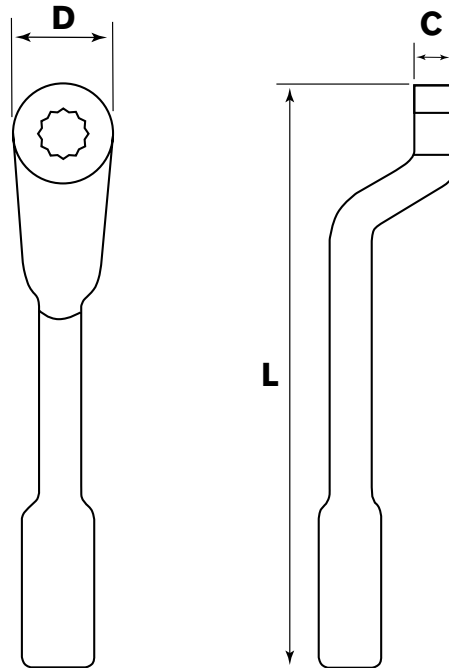

Striking Wrench Adapter

PART#	DESCRIPTION
FSWA16	1" M x 1" F
FSWA12	3/4" M x 3/4" F



Torque Multipliers

TM7550 and TM1075

OZAT's Torque Multipliers are quality made in the USA and are a must for anybody working in maintenance, production and equipment service where high torque applications are present. Using a planetary gear train at a ratio of 4 to 1, the input torque increases the output torque by 4 times. Made of the finest quality materials and precision machining the ATP Torque Multipliers will reach torque levels easier and more efficiently. Less stress on the operators means a safer quality of work. Using a standard hand ratchet, torque measuring ratchet or other source of input torque and a socket on the output drive simply place the socket on the item to be turned and brace the reaction bar against a solid fixed object. The force applied to the input will be multiplied 4X to the output. Use for installation or breaking loose stubborn fasteners. The small size can fit into many tight applications where other tools cannot.

OZAT's Torque Multipliers can be used in combination to achieve even higher torque values up to the maximum output capacity of the largest multiplier.

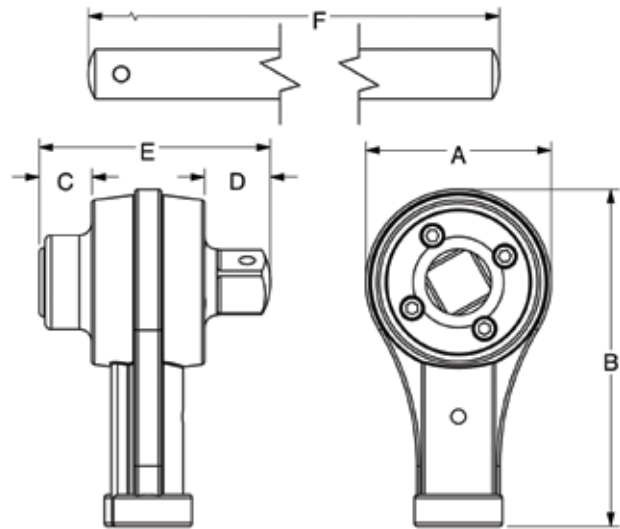

TM Specifications

MODEL	*OUTPUT TORQUE	**INPUT DRIVE in	OUTPUT DRIVE in	GEAR RATIO	WEIGHT	OVERALL LENGTH in	A in	B in	C in	D in	E in	F in
TM 7550	1000	1/2	3/4	4 to 1	7 Lbs.	23.50	3.50	7.00	.50	.75	3.50	18.88
TM 1075	2000	3/4	1	4 to 1	14 Lbs.	24.25	3.75	6.60	.75	1	4.63	20.50

* Output torque may vary +/- due to friction loss per multiplier

** Impact tools should not be used with OZAT torque multiplier



Reaction Bar Included

OZAT NON STANDARD SPECIALS DESCRIPTION FOR QUOTATION

COMPANY: _____ **CONTACT:** _____

ADDRESS: _____

PHONE No: _____ **FAX:** _____ **E-MAIL:** _____

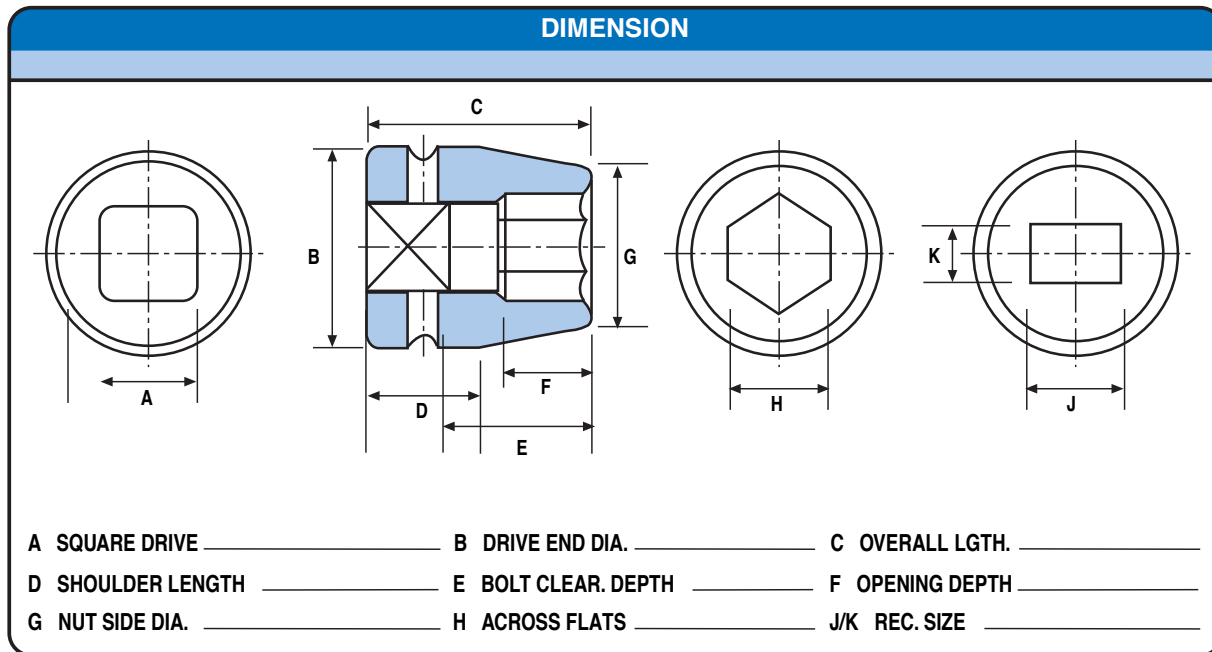
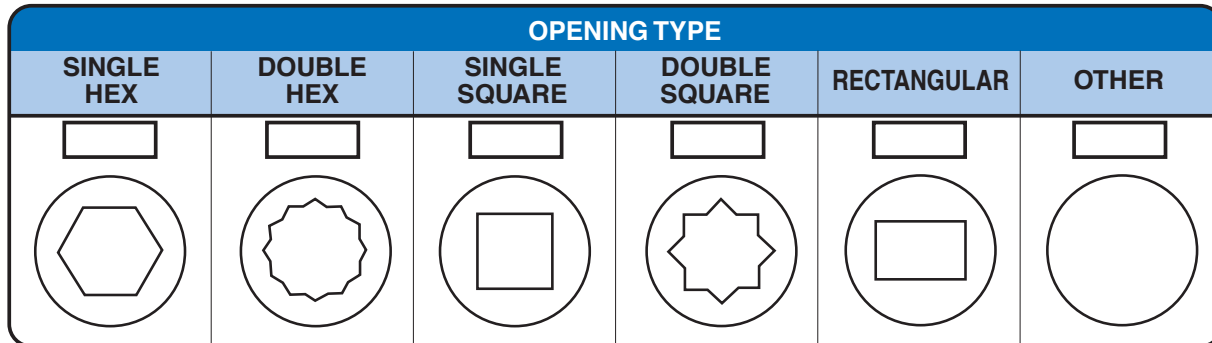
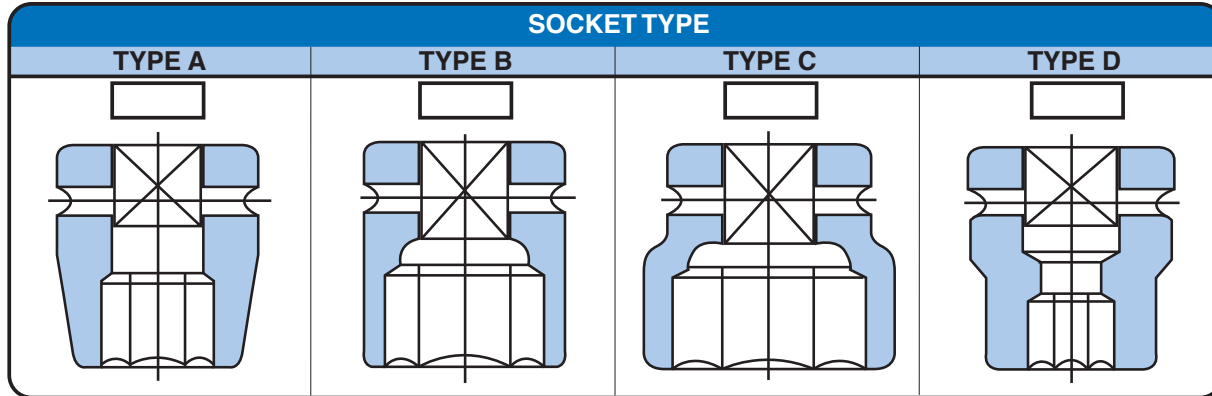

APPLICATION/COMMENTS: _____ **QUANTITY(S)** _____

Send OZAT specials request for quotation to customer service FAX: 724-776-0227, or info@hy-techinc.com



HIGH PRESSURE HYDROSTATIC TEST PLUGS

THAXTON specializes in engineering and manufacturing high quality test plugs used in hydrostatic testing of tubes, open end pipes, pipelines and pressure vessels.

PRECISION MACHINED HARDENED STEEL, ZINC PLATED, FACTORY TESTED

Standard pipe test plugs are factory tested up to 3,000 PSI depending on size. Special sizes and higher pressures can be supplied per customer requirements. Test plugs are held in place by the steel grips which hold against the inside wall of the pipe when the nut is tightened. At the same time, a neoprene seal cup is compressed to make a tight seal. New seal kits may be purchased directly from the factory to prolong the useful life of a Thaxton test plug.

NON-STANDARD TEST PLUGS ARE AVAILABLE FROM THAXTON

For special Non-Standard Test Plugs, please include the following information:

- Inside Diameter of Pipe
- Wall Thickness
- Depth Required
- Pipe Material
- Type of Test Media (Water, Oil, Gases, etc.)

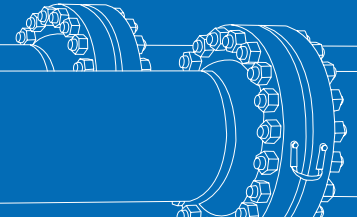

WARNING: Pressure testing can be severely hazardous and safety precautions must be followed.

WARNING: THAXTON test plugs are not to be used as lifting devices.

SAFETY GAGS

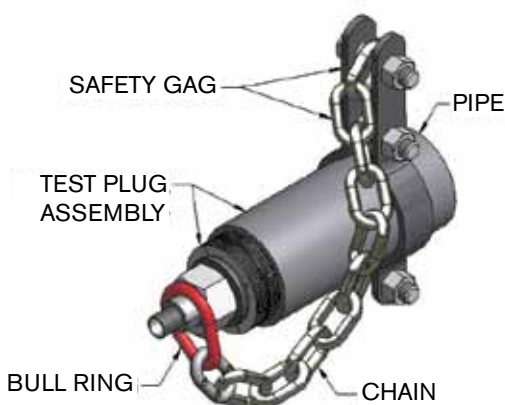

The gag is installed after the test plug is in place. The clamp is tightened around the pipe, with the bull ring located loosely over the stem. If the chain tightens, this would signal the operator to reduce pressure and retighten the test plug. The clamp also will restrict expansion of the pipe.

Safety Gags are available for all sizes and recommended for use in pressure testing operations.

THAXTON Test Plugs

TYPE C

Pipe I.D. Sizes .466" to 1.00"



- Mandrel through hole for filling and venting.
- Specifically designed for smooth concentric inside diameter pipe or tubing.
- Tolerances to plus or minus .005".

TYPE D

Pipe I.D. Sizes 1" to 2.5"



- Mandrel through hole for filling and venting.
- Special sizes are available on request.
- Made to fit a specific I.D. with tolerances plus or minus .020".

TYPE D

Pipe I.D. Sizes 3" to 17.5"



- Mandrel through hole for filling and venting.
- Special sizes are available on request.
- Made to fit a specific I.D. with tolerances plus or minus .035".

TYPE E External Closure

Pipe I.D. Sizes .5" to 2.5"



- Thaxton External Closures are designed to quickly seal a plain-end pipe or tube, and eliminate welding on a cap for hydrostatic testing. A perfect leak-free seal can be achieved every time at high pressures.
- Manufactured from alloy steel or stainless steel.

THAXTON Test Plugs

SOCKET WELD PLUGS - Pipe I.D. Sizes .5", .75", 1", 1.25", 1.5", 2"



- Special sizes are available on request.
- All Socket Weld Plugs are available with solid or vented stems.
- Our Socket Weld Plugs eliminate the need for welding plugs onto standard socket weld openings when conducting pressure tests.

REVERSE PRESSURE PLUGS - Pipe I.D. Sizes 1.25" to 12"



- Thaxton Reverse Pressure Plugs permit testing in a relatively small section of pipe. This avoids filling long sections of pipe with water in order to hydrostatic test a particular weld or segment. Reverse plugs have a solid stem and are held in place by hardened steel reverse grips. The seal is made with a neoprene ring and all steel parts are plated to resist corrosion.
- The stem of each plug has an internal left hand thread to accommodate installation tools (pictured below).



LARGE DIAMETER PIPE PLUGS - Pipe I.D. Sizes 18" to 24"



- Due to the size and weight of the parts, these test plugs are furnished with a series of draw bolts used for expanding the grip segments. The draw bolts allow the installer to expand the grip segments evenly.
- These test plugs are equipped with a female pipe thread in the bottom of the mandrel which allows the customer to install a vent tube, by using a street ell and the appropriate length of pipe. The vent tube will help remove air pockets from the pipe when conducting hydrostatic tests.

What's Turning Inside Matters



QUALITY GEAR

CUSTOM GEARS

Our Name Means Quality

Quality Gear takes pride in providing our unique gearing related manufacturing services. We can design new parts from scratch or replicate old and obsolete items from samples or customer drawings, delivering solutions that meet or surpass original specifications.



We combine the planning, design, programming, production, assembly and equipment capabilities of a large company with the innovation, precision and personal attention afforded by a one-on-one customer focused organization.

***For Gear Solutions with Quick Turn Around Times,
Call or Email for a Quote
sales@qualitygearmfg.com***

Phone: (814) 938-5552

Fax: (814) 938-5592

Web: qualitygearmfg.com

188 Bloese Drive Punxsutawney PA 15767

Custom Gearing Services:

- Hobbing and Shaping Services

- CNC Lathe, Turning and Milling Machining Centers

- CNC, OD, ID, Surface and Center-less Grinding

- Broaching Keyways and Internal Splines

- Profiling to reduce noise and vibration

- Vertical and Horizontal CNC Milling

- Keyseat Cutting and Honing

- 3 and 4-Axis Lathes



Bevel Gear



Bevel Sprocket



Bronze Helical



Counterbalance Gear



Double Helicals



Helical Shafts



Herringbone Pinions



Internal Couplings



Internal Gear



Internal Spline



Modified Spur Gear



Plastics - All Grades



Standard Rack



Special Rack



Segment Gears



Specialty Spline



Spiral Bevel



Splined Bevel Gear



Splined Spur Gear



Spur Gear



Spur Pinion



Straight Bevel



Timing Pulley



Worm Gear



Worm Gear Sets



Worm Shaft

- *Alloys*
- *Aluminum*
- *Brass*
- *Bronze*
- *Steel*
- *All Grades of Plastics*

- *O.D. from 1/4" to 40" Diameter*
- *I.D. to 25" Diameter*

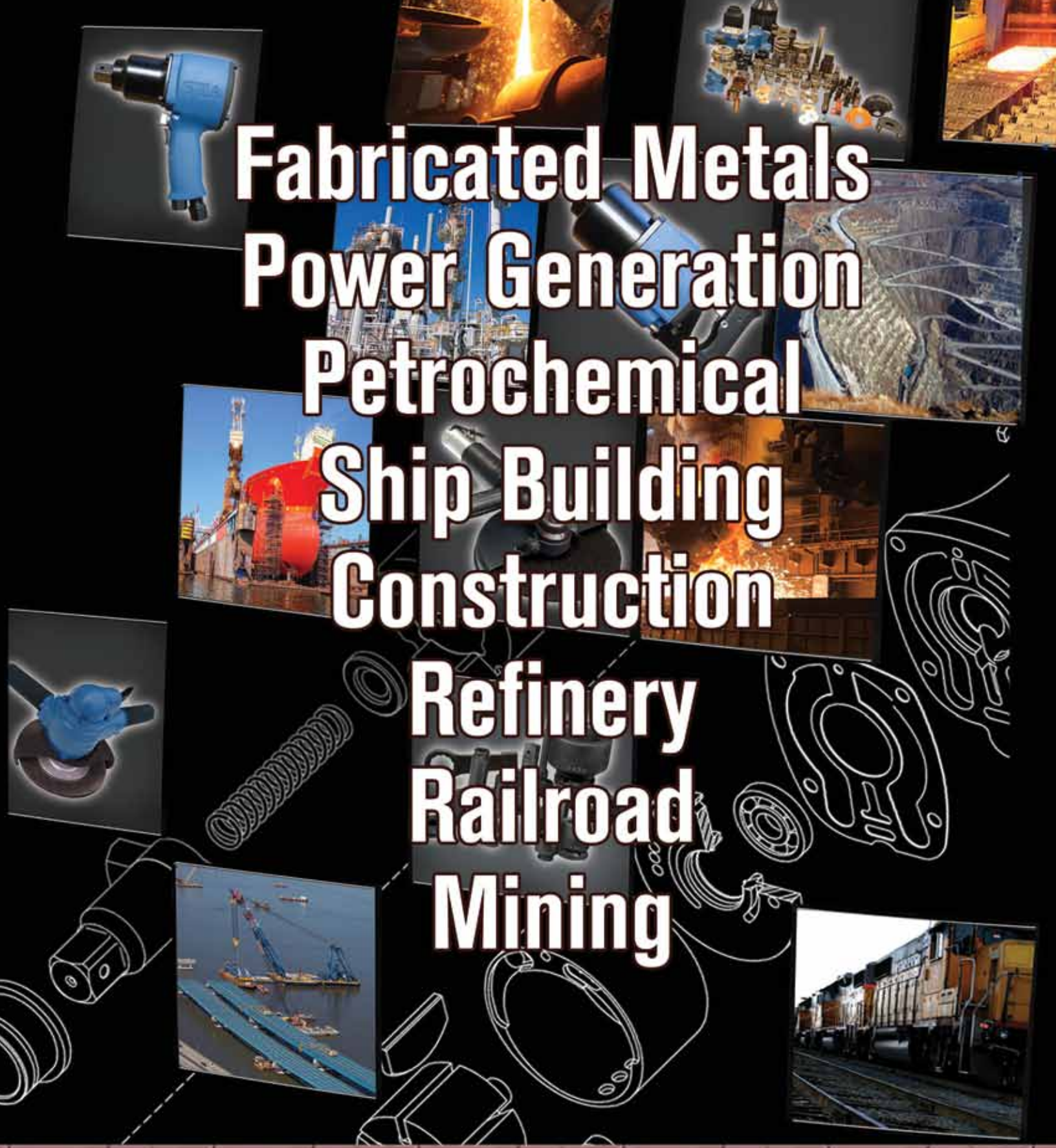

**Fabricated Metals
Power Generation
Petrochemical
Ship Building
Construction
Refinery
Railroad
Mining**

Distributed by:

HTC2019