



# UNIVERSAL AIR TOOLS

PRODUCT CATALOGUE



CELEBRATING  
44 YEARS OF QUALITY  
1974 - 2018



Proud sponsors of  
Arden International  
Motorsport



Universal Air Tool Company Limited, Unit 8 Lane End Industrial Park, High Wycombe, HP14 3BY



UT IS RECOGNISED AS THE UK'S LEADING INDEPENDENT SPECIALIST SUPPLIER OF HIGH QUALITY AIR TOOLS TO THE GARAGE, TYRE, BODYSHOP AND INDUSTRIAL MARKETS



Proud sponsors of  
Arden International  
Motorsport

**CELEBRATING OUR 44TH YEAR IN 2018**, we are proud of our reputation for exceptional service and high quality, performance-proven products. Our values have not changed since the Company was founded by Douglas Moppett in 1974: to offer a highly competitive range of air tools with the quality and extensive availability to rival any global brand, while maintaining the trust and ease of doing business which comes from dealing with a traditional family company.

#### UNIVERSAL TOOL USERS CAN EXPECT:

- Products incorporating the very latest features and benefits in air tool design.
- A nationwide distributor network and specialist advice just a phone call away.
- Nationwide service centres and industry-leading spare parts availability.
- The consistent high quality and performance denoted by the UT logo.

#### UNIVERSAL TOOL DISTRIBUTORS CAN RELY ON:

- Dedicated Area Sales Managers who are pro-active in helping you to win business.
- Extensive stock of tools and spare parts in our UK distribution centre, available for next day delivery. Area Sales Managers also carry stock for immediate delivery.
- Exceptional after sales service and support with straightforward repairs and warranties.
- The long term stability, simplicity and fairness of doing business with a family company. An outstanding team of people are here to help you and if you wish, you can speak directly to the owners at any time.

#### UT IS RECOGNISED WORLDWIDE AS A MARK OF AIR TOOL QUALITY AND OUR EXPORT CUSTOMERS ENJOY:

- The confidence in quality of our internationally respected British air tool brand.
- Immediate availability from stock and competitive worldwide freight options.
- In-house expertise to provide export documentation such as EU Certificates of Origin certified by the British Chamber of Commerce.

Universal Tools are rigorously tested to meet the appropriate international standards of safety including EC Machinery Directive 2006/42/EC. All tools come complete with a Declaration of Conformity and carry full product liability insurance.

Our prominent market position has been won by maintaining an acute interest in our customers' requirements and total specialisation within the pneumatic tool market. Quality control is carried out both in the factories and in-house to ensure that we deliver the consistency of quality that demanding professionals have come to expect from UT.

CELEBRATING  
44 YEARS OF QUALITY  
1974 - 2018

# CONTENTS



- 4 **RATCHET WRENCHES**
- 8 **IMPACT WRENCHES**  
*including sockets, socket sets, tool trolley,  
protective covers, adaptors & universal joints*
- 14 **DRILLS**
- 18 **SCREWDRIVERS**
- 22 **SANDERS**  
*including sanding belts & pads, backing pads,  
smart repair tool accessories & spares*
- 27 **POLISHERS**  
*including sisal mops, polishing mops, backing pads & more*
- 29 **GRINDERS**  
*including collets, dust extraction, grinding discs & tyre buffer*
- 35 **HAMMERS**  
*including chisels & spring retainers*
- 38 **AIR SAWS**  
*including saw blades*
- 40 **CUTTING TOOLS**  
*including cutting discs & nibbler accessories*
- 42 **NEEDLE SCALERS**  
*including needle sets*
- 45 **SPRAY GUNS**
- 46 **RIVETERS**  
*including spares*
- 48 **MISCELLANEOUS**  
*plus spares & accessories*
- 52 **TOOL OIL**  
*our recommended lubricants*
- 53 **HOSES**  
*including couplings & regulators*
- 55 **INFORMATION**  
*warranty, best practice & setup*





# 1

# RATCHET WRENCHES

## UT8000S38

### STUBBY RATCHET WRENCH 3/8" SQ.DR.

Perfect for working in confined areas

Speed 350 rpm

Max torque 30 ft/lbs (41 Nm)

Av Air Con 4 cfm

Weight 0.5 kg

Vibration Level 2.6 m/sec<sup>2</sup>

Sound Level 85 db(a)

Length 133 mm

Air Inlet 1/4 bsp



HIGHLY DURABLE YOKE FOR LONG SERVICE LIFE

EASY FORWARD/REVERSE

SHORT & COMPACT FOR ACCESS TO TIGHT SPACES

LOW WEIGHT COMPOSITE MOTOR HOUSING

REAR EXHAUST

# 4

Information, orders & expert advice: Call 01494 883300 | Email [sales@universal.co.uk](mailto:sales@universal.co.uk)

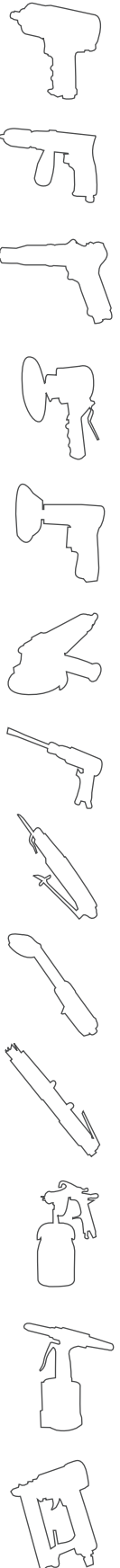

**UT8000REA**

**1/4" MINI COMPOSITE RATCHET WRENCH**

Complete with exhaust hose



Speed 200 rpm  
 Max Torque 20 ft lbs (27 Nm)  
 Avg Air Cons 4 cfm  
 Nett Weight 0.5 kg  
 Vibration Level 3.3 m/sec<sup>2</sup>  
 Sound Pressure 82.0 db(a)  
 Length 170 mm  
 Height 39 mm  
 Air Inlet 1/4 bsp

**UT8000S14**

**STUBBY RATCHET WRENCH 1/4" SQ.DR.**

For working in confined areas



Speed 350 rpm  
 Max torque 30 ft/lbs (41 Nm)  
 Av Air Con 4 cfm  
 Weight 0.5 kg  
 Vibration Level 2.6 m/sec<sup>2</sup>  
 Sound Level 85 db(a)  
 Length 133 mm  
 Air Inlet 1/4 bsp

**UT8000REB**

**3/8" MINI COMPOSITE RATCHET WRENCH**

Complete with exhaust hose



Speed 200 rpm  
 Max Torque 20 ft lbs (27 Nm)  
 Avg Air Cons 4 cfm  
 Nett Weight 0.5 kg  
 Vibration Level 3.3 m/sec<sup>2</sup>  
 Sound Pressure 82.0 db(a)  
 Length 170 mm  
 Height 39 mm  
 Air Inlet 1/4 bsp

**UT8004**

**3/8" MINI RATCHET WRENCH**

With socket release button



Speed 250 rpm  
 Max Torque 30 ft lbs (41 Nm)  
 Avg Air Cons 3.5cfm  
 Nett Weight 1.15 kg  
 Vibration Level 5.7 m/sec<sup>2</sup>  
 Sound Pressure 94.0 db(a)  
 Length 197 mm  
 Height 41 mm  
 Air Inlet 1/4 bsp

**UT2005-1**

**3/8" RATCHET WRENCH**

Triple idle gear for smooth operation

With comfort grip



Speed 160 rpm  
 Max Torque 50 ft lbs (68 Nm)  
 Avg Air Cons 4 cfm  
 Nett Weight 1.1 kg  
 Vibration Level 5.90 m/sec<sup>2</sup>  
 Sound Pressure 95.0 db(a)  
 Length 254 mm  
 Height 40 mm  
 Air Inlet 1/4 bsp



UNIVERSAL  
AIRTOOLS

THREE TIMES FASTER THAN  
STANDARD RATCHET WRENCHES

PIN CLUTCH IMPACT MECHANISM WHICH  
ABSORBS THE TORQUE REACTION AND  
REDUCES THE RISK OF INJURY

## UT8011R

### REACTIONLESS RATCHET WRENCH 1/2" SQ.DR.

Heavy duty ratchet wrench with built-in impact mechanism to deliver 90 ft lbs of torque while absorbing the snap reaction on the operator's wrist. Excellent for high torque fasteners in confined spaces where a reactionless tool is particularly desirable to prevent hand and finger trapping

Speed 400 rpm

Max Torque 90 ft/lbs (122 Nm)

Av Air Con 4 cfm

Weight 1.28 kg

Vibration Level 9.9 m/sec<sup>2</sup>

Sound Level 90 db(a)

Length 280 mm

Air Inlet 1/4 bsp



COMFORTABLE RUBBER GRIP

REAR EXHAUST

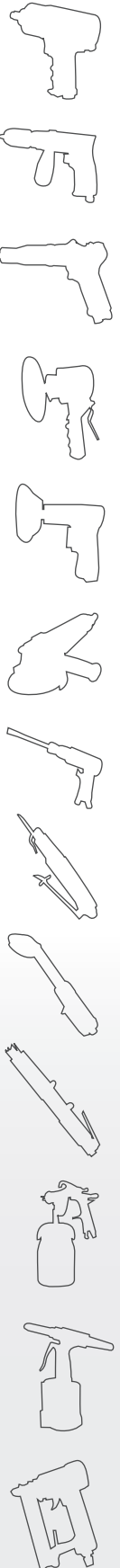

**UT8001R**

**REACTIONLESS RATCHET WRENCH 3/8" SQ.DR.**

Greatly reduces the snap reaction on the operator's wrist when max torque is reached



- Speed 400 rpm
- Max Torque 90 ft/lbs (122 Nm)
- Av Air Con 4 cfm
- Weight 1.28 kg
- Vibration Level 9.9 m/sec<sup>2</sup>
- Sound Level 90 db(a)
- Length 280 mm
- Air Inlet 1/4 bsp

**UT8961-2NR**

**3/8" AUTO-SHUTOFF PRECISION NUTRUNNER**

Torque controlled, lever start with automatic shutoff at highly accurate desired torque



- Speed 400 rpm
- Av Air Con 4 cfm
- Weight 1.3 kg
- Vibration Level 1.8 m/sec<sup>2</sup>
- Sound Pressure 78.0 db(a)
- Torque Range 44-88 lbs ins (5-10 Nm)
- Length 254 mm
- Angle head Height 47 mm
- Air Inlet 1/4 bsp

**UT2005H-1**

**1/2" RATCHET WRENCH**

With comfort grip



- Speed 160 rpm
- Max Torque 50 ft lbs (68 Nm)
- Avg Air Cons 4 cfm
- Nett Weight 1.1 kg
- Vibration Level 5.90 m/sec<sup>2</sup>
- Sound Pressure 95.0 db(a)
- Length 254 mm
- Height 40 mm
- Air Inlet 1/4 bsp

**SEE OUR WIDE RANGE OF SOCKET & SOCKET SETS ON PAGE 13**





2

# IMPACT WRENCHES



POWERFUL TWIN HAMMER MECHANISM

MOULDED-IN BUFFERS PROTECT TOOL FROM IMPACT

HIGH/LOW TORQUE BUTTON

FORWARD/REVERSE BUTTONS

## UT8176

### 1/2" HIGH-LOW TORQUE IMPACT WRENCH

Well balanced, heavy duty impact wrench delivering high torque and comfortable one handed operation

Speed 6,500 rpm

Impacts Per Min 1,600

Max Torque 800 ft lbs (1085 Nm)

Length 185 mm

Weight 1.99 kg

Vibration Level 3.2 m/sec<sup>2</sup>

Sound Pressure 88.0 db(a)

Air Inlet 1/4 bsp

“ONE HANDED OPERATION”

ERGONOMICALLY DESIGNED GRIP FOR OPERATOR COMFORT





**UT8030RA**

**3/8" PISTOL IMPACT WRENCH**

Single hammer mechanism



Speed 10,000 rpm  
 Avg Air Cons 7.5 cfm  
 Max Torque 75 ft lbs (102 Nm)  
 Weight 1.3 kg  
 Vibration Level 8.7 m/sec<sup>2</sup>  
 Sound Pressure 94.2 db(a)  
 Length 133 mm  
 Height 165 mm  
 Air Inlet 1/4 bsp

**UT8026**

**3/8" COMPOSITE IMPACT WRENCH**

Through handle exhaust  
 Twin hammer mechanism



Speed 9,000 rpm  
 Avg Air Cons 3.2 cfm  
 Max Torque 300 ft lbs (407 Nm)  
 Weight 1.2 kg  
 Vibration Level 5 m/sec<sup>2</sup>  
 Sound Pressure 85.0 db(a)  
 Length 165 mm  
 Height 160 mm  
 Air Inlet 1/4 bsp

**UT8070R-1/UT8070P-1**

**3/8" PISTOL IMPACT WRENCH**

RB = Ring Retainer, PB = Pin Retainer

Twin pin hammer mechanism with cushion  
 comfort grip and steel front housing



Speed 12,000 rpm  
 Avg Air Cons 9.4 cfm  
 Max Torque 300 ft lbs (406Nm)  
 Weight 1.5 kg  
 Vibration Level 7.0 m/sec<sup>2</sup>  
 Sound Pressure 96 db(a)  
 Length 140 mm  
 Height 168 mm  
 Air Inlet 1/4 bsp

**UT8025R-1**

**3/8" BUTTERFLY IMPACT WRENCH**

Single hammer mechanism  
 Press right for forward – Press left for reverse



Speed 11,000 rpm  
 Avg Air Cons 7.5 cfm  
 Max Torque 75 ft lbs (102 Nm)  
 Nett Weight 1.1 kg  
 Vibration Level 13.4 m/sec<sup>2</sup>  
 Sound Pressure 105.0 db(a)

Length 159 mm  
 Height 55 mm  
 Air Inlet 1/4 bsp

**HP144**

**CORDLESS 3/8" IMPACT WRENCH**

No Load Speed 2,400 rpm  
 Max Torque 87 ft lbs (118 Nm)  
 Impacts per min 3,150  
 Weight 2.0 kg  
 Vibration Level 6.6 m/sec<sup>2</sup>  
 Sound Pressure 90.8 db(a)  
 Volt DC 14.4 v  
 Charge Time 1 hour  
 Length 210 mm  
 Height 230 mm  
 Battery Capacity 1.3 Ah



**UT8125**

**1/2" MINI PISTOL COMPOSITE IMPACT WRENCH**

Through handle exhaust  
 Twin hammer mechanism



Speed 9,000 rpm  
 Av Air Con 3.2 cfm  
 Max Torque 300 lbs ft (407 Nm)  
 Weight 1.2 kg  
 Vibration Level 5 m/sec<sup>2</sup>  
 Sound Pressure 85 db(a)  
 Length 165 mm  
 Height 160 mm  
 Air Inlet 1/4 bsp

**BGA12 14.4 VOLT BATTERY PACK**

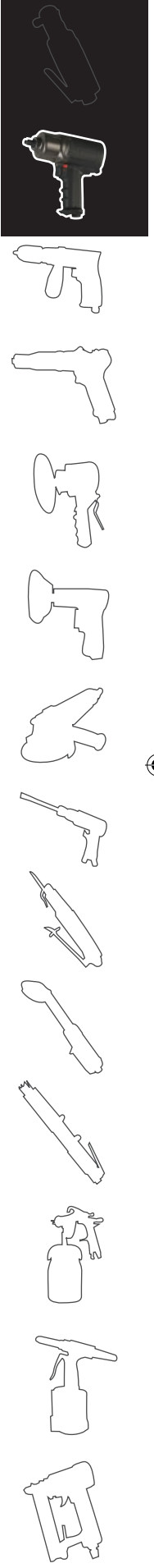



## IMPACT WRENCHES

### UT2147R-1

#### 1/2" IMPACT WRENCH

Smooth-fast Dynapact® clutch-500 ft.lb. max. torque



Speed 8,000 rpm  
Av Air Con 6.5 cfm  
Max Torque 500 lbs ft (675 Nm)  
Weight 2.6 kg  
Vibration Level 6.7 m/sec<sup>2</sup>  
Sound Pressure 98.5 db(a)  
Length 191 mm  
Height 180 mm  
Air Inlet 1/4 bsp

### UT8138

#### 1/2" MEDIUM DUTY IMPACT WRENCH

Twin pin mechanism  
Through handle exhaust

UT8138K kit  
also available



Speed 8,000 rpm  
Av Air Con 4.2 cfm  
Max Torque 780 ft lbs (1,054 Nm)  
Weight 2.1 kg  
Vibration Level 5.3 m/sec<sup>2</sup>  
Sound Pressure 87.0 db(a)  
Length 192 mm  
Height 192 mm  
Air Inlet 1/4 bsp

### UT8126

#### 1/2" PISTOL COMPOSITE IMPACT WRENCH

Through handle exhaust  
Twin hammer mechanism

Complete with BOOT12



Speed 6,000 rpm  
Av Air Con 5.7 cfm  
Max Torque 580 lbs ft (786 Nm)  
Weight 2.0 kg  
Vibration Level 6.75 m/sec<sup>2</sup>  
Sound Pressure 85 db(a)  
Length 195 mm  
Height 170 mm  
Air Inlet 1/4 bsp

### UT8126K

#### 1/2" IMPACT WRENCH KIT

Impact socket sizes: 16, 17, 19, 22 & 24 mm



### UT8175R

#### 1/2" COMPOSITE IMPACT WRENCH

Twin hammer mechanism  
Through handle exhaust

UT8175RK kit  
also available



Speed 7,000 rpm  
Av Air Con 4.0 cfm  
Max Torque 780 ft lbs (1,054 Nm)  
Weight 1.9 kg  
Vibration Level 6.8 m/sec<sup>2</sup>  
Sound Pressure 83.0 db(a)  
Length 183 mm  
Height 192 mm  
Air Inlet 1/4 bsp



**HP180LI**

**1/2" CORDLESS  
18V LI-ION  
IMPACT WRENCH**

Kit includes 2 batteries  
Variable speed switch  
Replaceable carbon brushes

- No Load Speed 1,800 rpm
- Max Torque 400 ft lbs (542 Nm)
- Impacts per min 2,300
- Weight 2.9 kg
- Vibration Level 5.89 m/sec<sup>2</sup>
- Sound Pressure 98.0 db(a)
- Volt DC 18.0 v
- Charge Time 1 hour
- Length 254 mm
- Height 269 mm
- Battery Capacity 3.0 Ah



**HP180BC**

18V LI-ION  
CHARGER



**HP180BAT**

18V LI-ION  
BATTERY PACK



**HP180CAR**

18V LI-ION  
CAR CHARGER



**UT5315**

**3/4" IMPACT WRENCH**

Twin pin hammer mechanism

- Speed 5,000 rpm
- Weight 4.8 kg
- Av Air Con 8 cfm
- Man Torque 850 ft lbs (1135 Nm)
- Vibration Level 5.8 m/sec<sup>2</sup>
- Sound Pressure 85.7 db(a)
- Length 253 mm
- Height 200 mm
- Air Inlet 1/4 bsp



**UT8326**

**3/4" PISTOL COMPOSITE IMPACT WRENCH**

Through handle exhaust  
Twin hammer mechanism  
Complete with BOOT34

- Speed 4,000 rpm
- Av Air Con 6.3 cfm
- Max Torque 800 lbs ft (1085 Nm)
- Weight 3.8 kg
- Vibration Level 4.2 m/sec<sup>2</sup>
- Sound Pressure 85.0 db(a)
- Length 244 mm
- Height 210 mm
- Air Inlet 3/8 bsp



**UT8340C-2**

**3/4" PISTOL IMPACT WRENCH**

Hard hitting twin hammer-1400 ft.lbs. max. torque  
Combined reverse and power management switch

- Speed 6,500 rpm
- Av Air Con 10 cfm
- Max torque 1,400 ft lbs (1890 Nm)
- Weight 4.54 kg
- Vibration Level 8.24 m/sec<sup>2</sup>
- Sound Pressure 90.8 db(a)
- Length 210 mm
- Height 230 mm
- Air Inlet 3/8 bsp



**UT8360C-1**

**3/4" PISTOL IMPACT WRENCH**

Twin hammer mechanism  
Through handle exhaust

- Speed 6,500 rpm
- Av Air Con 7 cfm
- Max Torque 1,400 lbs ft (1890 Nm)
- Weight 3.36 kg
- Vibration Level 8.24 m/sec<sup>2</sup>
- Sound Pressure 91.3 db(a)
- Length 210 mm
- Height 225 mm
- Air Inlet 3/8 bsp

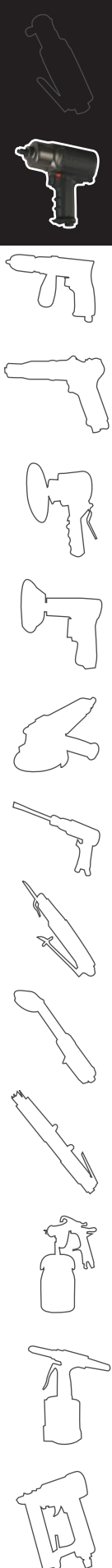



## IMPACT WRENCHES

### UT8468 / UT8468S

#### 1" SQ.DR.LIGHTWEIGHT IMPACT WRENCH

Straight rear handle  
Short anvil available

Speed 6,000 rpm  
Av Air Con 10 cfm  
Max Torque 1,800 ft/lbs (2,441 Nm)  
Weight 7.5 kg  
Vibration Level 6.6 m/sec<sup>2</sup>  
Sound Level 96 db(a)  
Air Inlet 1/2 bsp



### UT8468AH / UT8468AHS

#### 1" SQ.DR.LIGHTWEIGHT IMPACT WRENCH

Cranked rear handle  
Short anvil available



### UT8420 / UT8420S

#### VERY HIGH PERFORMANCE 1" IMPACT WRENCH

Short anvil available  
Unique low wear pinless  
hammer design

UT8420K kit available in  
moulded case  
with 8 Deep Impact Sockets  
(24, 27, 29,  
30, 32, 33, 36, 38 mm)



Speed 4,500 rpm  
Av Air Con 12 cfm  
Max Torque 2,300 ft lbs  
(3,116 Nm)  
Weight 14.5 kg  
Vibration Level 8.9 m/sec<sup>2</sup>  
Sound Pressure 103 db(a)  
Length 521 mm  
Height 180 mm  
Air Inlet 1/2 bsp

### UT8419 / UT8419S

#### 1" IN LINE IMPACT WRENCH 8" EXTENDED ANVIL

Short anvil available

UT8419K kit  
available in  
moulded case with  
8 Deep Impact  
Sockets (24, 27, 29,  
30, 32, 33, 36, 38 mm)



Speed 4,500 rpm  
Av Air Con 12 cfm  
Max Torque 1,800 ft lbs  
(2440 Nm)  
Weight 11.59 kg  
Vibration Level 9.5 m/sec<sup>2</sup>  
Sound Pressure 108.4 db(a)  
Length 521 mm  
Height 180 mm  
Air Inlet 1/2 bsp

### UT8470C

#### 1" PISTOL IMPACT WRENCH

Hard hitting twin hammer  
Three piece housing design  
eases maintenance

Speed 4,000 rpm  
Av Air Con 11.0 cfm  
Max torque 1,900 ft lbs (2,572 Nm)  
Weight 9 kg  
Vibration Level 9.33 m/sec<sup>2</sup>  
Sound Pressure 102.0 db(a)  
Length 300 mm  
Height 270 mm  
Air Inlet 3/8 bsp



### UT150

#### 1 1/2" IMPACT WRENCH

Twin hammer mechanism

Speed 3,000 rpm  
Max torque 3,900 ft lbs  
(5288 Nm)  
Av Air Con 20 cfm  
Weight 16.1 kg  
Vibration Level 9.7 m/sec<sup>2</sup>  
Sound Pressure 98.6 db(a)  
Length 443 mm  
Height 150 mm  
Air Inlet 1/2 bsp





### 1/2" SINGLE DEPTH SOCKETS



1/2" Drive Metric	
9mm	SM1209
10mm	SM1210
11mm	SM1211
12mm	SM1212
13mm	SM1213
14mm	SM1214
15mm	SM1215
16mm	SM1216
17mm	SM1217
18mm	SM1218
19mm	SM1219
20mm	SM1220
21mm	SM1221
22mm	SM1222
23mm	SM1223
24mm	SM1224
25mm	SM1225
26mm	SM1226
27mm	SM1227
28mm	SM1228
29mm	SM1229
30mm	SM1230
32mm	SM1232
33mm	SM1233
34mm	SM1234

For deep sockets add DD

### 3/4" & 1" DOUBLE DEPTH SOCKETS



3/4" Drive Metric	
24mm	SM3424
26mm	SM3426
27mm	SM3427
28mm	SM3428
29mm	SM3429
30mm	SM3430
32mm	SM3432
33mm	SM3433
34mm	SM3434
35mm	SM3435
36mm	SM3436
38mm	SM3438

1" Drive Metric	
27mm	SM127
28mm	SM128
29mm	SM129
30mm	SM130
32mm	SM132
33mm	SM133
34mm	SM134
35mm	SM135
36mm	SM136
37mm	SM137
38mm	SM138
41mm	SM141
46mm	SM146

For short sockets add SD

Imperial sizes also available

### PROTECTIVE COVERS



To fit 1/2" impact wrench  
To fit 3/4" impact wrench

Part No.  
BOOT12 or 700926  
BOOT34 or B82607580200

SEE OUR

### WHIP HOSES, OIL & OTHER AIRLINE ACCESSORIES

ON PAGES 52-53



### H0015

#### TOOL TROLLEY

For transportation of wrenches etc. Complete with lubricator, filter, regulator and hose

3m x 1/2" leader hose and 20m x 1/2" hose

(H0014 - Tool Trolley Only)



### SOCKET SETS

H0082  
1/2" Square Drive  
Impact Socket Set



Socket sizes  
12, 13, 14, 15,  
16, 17, 18, 19,  
21, 22, 24 mm

H0082-MM  
1/2" Square Drive  
Deep Impact  
Socket Set



Socket sizes  
12, 13, 14, 15,  
16, 17, 18, 19,  
21, 22, 24 mm

H0086-1  
3/4" drive metric



Socket sizes  
24, 27, 29,  
30, 32, 33,  
36, 38mm

H0093-1  
1" drive metric



Socket sizes  
24, 27, 29,  
30, 32, 33,  
36, 38mm

H0095  
1" drive metric



Socket sizes  
27, 30,  
32, 33mm

### SOCKET ADAPTORS



3/8" female to 1/2" male  
1/2" female to 3/8" male  
1/2" female to 3/4" male  
3/4" female to 1/2" male  
3/4" female to 1" male  
1" female to 3/4" male  
1 1/2" female to 1" male

Part No.  
SA38F12M  
SA12F38M  
SA12F34M  
SA34F12M  
SA34F1M  
SA1F34M  
SA112F1M

### UNIVERSAL JOINTS



3/8" square drive  
1/2" square drive  
3/4" square drive  
1" square drive

Part No.  
UJ38  
UJ12  
UJ34  
UJ1

### EXTENSION BARS



	3"	6"	8"	10"	12"
3/8" square drive	EX383	EX386			
1/2" square drive	EX123	EX126		EX1210	EX1212
3/4" square drive		EX346	EX348	EX3410	EX3412
1" square drive		EX16	EX18	EX110	EX112

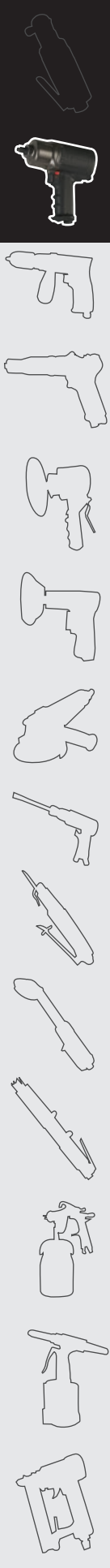



3

# DRILLS



## UT2855R

### 1/2" COMPOSITE REVERSIBLE DRILL – KEYLESS

Powerful and reliable Pro-Series drill, ergonomically designed for operator comfort and ideal for demanding applications

- Speed 450 rpm
- Motor Power 0.75 hp
- Av Air Con 4
- Weight 1.3 kg
- Vibration Level 1.1 m/sec<sup>2</sup>
- Sound Pressure 86 db(a)
- Length 228 mm
- Height 125 mm
- Chuck Thread Size 3/8 x 24
- Air Inlet 1/4 bsp

JACOBS KEYLESS CHUCK

HIGH PRECISION GEARING AND BEARINGS PROVIDE SUPERIOR TOLERANCE FOR ONLY 0.2MM RUN OUT

POWERFUL 0.75HP MOTOR FOR SUPERIOR STALL RESISTANCE

ERGONOMIC DESIGN FOR GREATER OPERATOR COMFORT

TEASE TRIGGER FOR ULTIMATE OPERATOR CONTROL

REMOVABLE 360° SIDE HANDLE



**UT8821**

**3/8" COMPOSITE DRILL - KEYLESS**

Powerful 0.5HP motor  
Tease trigger for ultimate operator control



Available either a keyed or keyless chuck

Speed 2,600 rpm  
Motor Power 0.5 hp  
Av Air Con 3.7 cfm  
Weight 0.9 kg  
Vibration Level 1.2 m/sec<sup>2</sup>    Height 125 mm  
Sound Pressure 91.0 db(a)    Chuck Thread Size 3/8 x 24  
Length 193 mm    Air Inlet 1/4 bsp

**UT2815R**

**3/8" REVERSIBLE DRILL**

0.75 HP Motor for extra stall resistance

Reliable planetary gear system



Available either a keyed or keyless chuck

Speed 1,800 rpm  
Motor Power 0.75 hp  
Av Air Con 3.5 cfm  
Weight 1.0 kg  
Vibration Level 1.2 m/sec<sup>2</sup>    Height 125 mm  
Sound Pressure 91.0 db(a)    Chuck Thread Size 3/8 x 24  
Length 165 mm    Air Inlet 1/4 bsp

**UT8817**

**3/8" REVERSIBLE COMPOSITE PISTOL DRILL**

Complete with keyless chuck

Available either a keyed or keyless chuck



Speed 1,700 rpm  
Av Air Con 4 cfm  
Weight 0.92 kg  
Vibration Level <2.5 m/sec<sup>2</sup>  
Sound Pressure 76 db(a)  
Length 159 mm  
Height 154 mm  
Chuck Thread Size 3/8 x 24  
Air Inlet 1/4 bsp

**UT5825**

**3/8" REVERSIBLE PISTOL DRILL**

Available either a keyed or keyless chuck

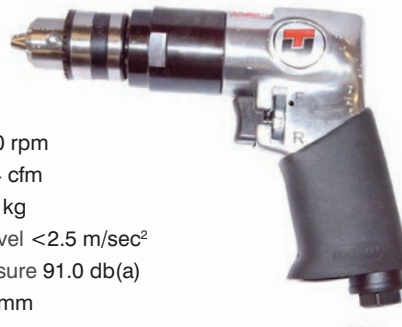

Speed 1,800 rpm  
Av Air Con 4 cfm  
Weight 1.36 kg  
Vibration Level <2.5 m/sec<sup>2</sup>  
Sound Pressure 91.0 db(a)  
Length 163 mm  
Height 125 mm  
Chuck Thread Size 3/8 x 24  
Air Inlet 1/4 bsp

**UT8841**

**3/8" COMPOSITE STRAIGHT DRILL - KEYLESS**

Powerful 0.5HP motor  
Available either a keyed or keyless chuck



Speed 3,600 rpm  
Av Air Con 3.7 cfm  
Weight 0.8 kg  
Vibration Level 3.6 m/sec<sup>2</sup>  
Sound Pressure 86.0 db(a)  
Length 223 mm  
Height 37 mm  
Chuck Thread Size 3/8 x 24  
Air Inlet 1/4 bsp

**UT8833R-1**

**3/8" REVERSIBLE PISTOL DRILL**

0.65 HP Motor for extra stall resistance

Available either a keyed or keyless chuck



Speed 1,800 rpm  
Av Air Con 3.5 cfm  
Weight 1.10 kg  
Vibration Level 2.1 m/sec<sup>2</sup>  
Sound Pressure 84.00 db(a)  
Length 163 mm  
Height 145 mm  
Chuck Thread Size 3/8 x 24  
Air Inlet 1/4 bsp

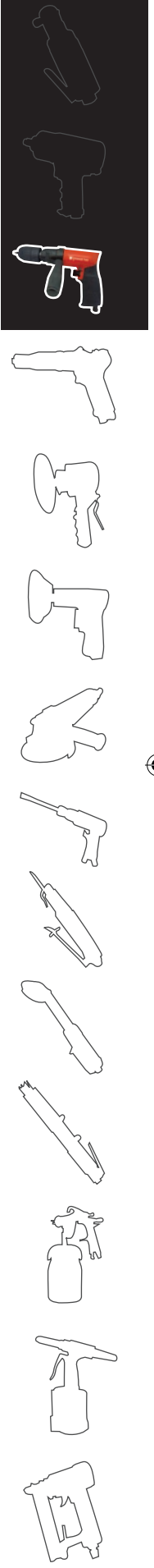



### UT5742D

#### 3/8" STRAIGHT DRILL

Complete with exhaust hose

Available either a keyed or keyless chuck



Speed 2,600 rpm  
 Av Air Con 4 cfm  
 Weight 1.1 kg  
 Vibration Level 2.0 m/sec<sup>2</sup>  
 Sound Pressure 79.0 db(a)  
 Length 235 mm  
 Height 39 mm  
 Chuck Thread Size 3/8 x 24  
 Air Inlet 1/4 bsp

### UT8806

#### 3/8" COMPOSITE ANGLE DRILL - KEYLESS

Powerful 0.5HP motor



Available either a keyed or keyless chuck

Speed 1,800 rpm  
 Motor Power 0.5 hp  
 Av Air Con 3.7 cfm  
 Weight 1.2 kg  
 Vibration Level 3.6 m/sec<sup>2</sup>  
 Sound Pressure 86.0 db(a)  
 Length 193 mm  
 Height 95 mm  
 Chuck Thread Size 3/8 x 24  
 Air Inlet 1/4 bsp

### UT8860R-1

#### 3/8" REVERSIBLE ANGLE DRILL

Also available as 1/2" - order UT8860R-1/2-1



Available either a keyed or keyless chuck

Speed 1,800 rpm  
 Av Air Con 4.6 cfm  
 Weight 1.1 kg  
 Vibration Level <2.5 m/sec<sup>2</sup>  
 Sound Pressure 83.9 db(a)  
 Length 178 mm  
 Height 72 mm  
 Chuck Thread Size 3/8 x 24  
 Angle Head Height 80 mm  
 Air Inlet 1/4 bsp

### UT2855R-7

#### 1/2" REVERSIBLE DRILL

0.75 HP Motor for extra stall resistance

Available either a keyed or keyless chuck



Speed 700 rpm  
 Motor Power 0.75 hp  
 Av Air Con 3.5 cfm  
 Weight 1.4 kg  
 Vibration Level 0.4 m/sec<sup>2</sup>  
 Sound Pressure 86 db(a)  
 Length 220.5 mm  
 Height 125 mm  
 Chuck Thread Size 3/8 x 24  
 Air Inlet 1/4 bsp





**UT8818**

**1/2" REVERSIBLE COMPOSITE PISTOL DRILL**

Available either a keyed or keyless chuck and removable side handle



Speed 750 rpm  
 Av Air Con 4 cfm  
 Weight 0.92 kg  
 Vibration Level <2.5 m/sec<sup>2</sup>  
 Sound Pressure 76 db(a)  
 Length 159 mm  
 Height 154 mm  
 Chuck Thread Size 3/8 x 24  
 Air Inlet 1/4 bsp

**UT8840R-1**

**1/2" REVERSIBLE DRILL**

Double injection ergonomically advanced housing and grip

Available either a keyed or keyless chuck



Speed 800 rpm  
 Av Air Con 3.5 cfm  
 Weight 1.3 kg  
 Vibration Level <2.5 m/sec<sup>2</sup>  
 Sound Pressure 84.0 db(a)  
 Length 216 mm  
 Height 145 mm  
 Chuck Thread Size 1/2  
 Air Inlet 1/4 bsp

**HP17RD**

**5/8" (16MM) INDUSTRIAL REVERSIBLE DRILL**

Fitted with JT3 Taper chuck (H0122)

Available either a keyed or keyless chuck



Speed 1,000 rpm  
 Av Air Con 10 cfm  
 Weight 4.6 kg  
 Vibration Level 12 m/sec<sup>2</sup>  
 Sound Pressure 85 db(a)  
 Motor Output 2.9 hp  
 Length 380 mm  
 Height 126 mm  
 Air Inlet 3/8 bsp

**DRILL ACCESSORIES**

**CHUCKS & KEYLESS CHUCKS**

- 3/8" Chuck and key - 3/8" UNF mount - all models
- 3/8" Chuck key (for use with H0019)
- 3/8" Keyless Chuck - 3/8" UNF mount - all models
- 1/2" Chuck and key - 3/8" UNF mount - all models
- 1/2" Chuck key (for use with H0020)
- 1/2" Keyless Chuck - 3/8" UNF mount - all models
- 5/8" Tapered chuck and key - (HP17RD)
- 3/8" UNF x 1/4" Hexagonal Slip Chuck - converts drills to drivers
- 3/8" UNF x 7/16" Hexagonal Slip Chuck - converts drills to buffers

- Part No.
- H0019
- H0023
- H0019K
- H0020
- H0024
- H0020K
- H0122
- 99005
- 10700161

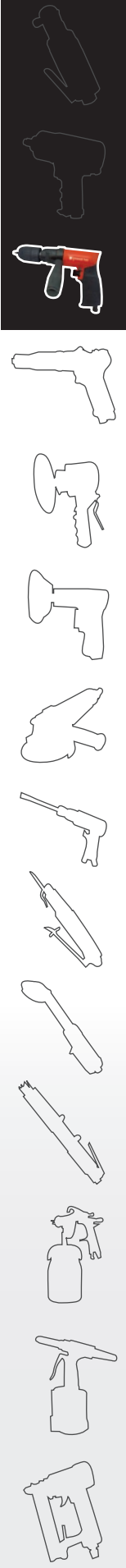



5

# SCREWDRIVERS



PUSH TO START - AUTO SHUT OFF AT DESIRED TORQUE

BUILT IN FITTING FOR TOOL BALANCER

EASY FORWARD/REVERSE

AIR INLET POSITION B

AIR INLET POSITION C

POWERFUL MOTOR WITH PRECISE TORQUE SETTINGS

CUSHIONED COMFORT HANDLE

REAR EXHAUST WITH INTEGRAL SILENCER

AIR INLET POSITION A

## UT8963

### 1/4" HEX COMPOSITE PISTOL SCREWDRIVER

Ideal for high precision applications where automatic shut off at an exact torque is desirable

Air can be supplied from the top, rear or bottom of the tool for ease of set up in conjunction with a tool balancer

Torque accuracy to within +/- 3% at 90psi

Speed 250 rpm

Av Air Con 4 cfm

Weight 1.1 kg

Vibration Level <2.5 m/sec<sup>2</sup>

Sound Pressure 76.4 db(a)

Max torque 44-265 lb ins (5-30 Nm)

Length 215 mm

Height 140 mm

Air Inlet 1/4 bsp



**UT8817-S**

**1/4" HEX DIRECT DRIVE SCREWDRIVER**

Comfortable, low-weight composite body



Speed 1,700 rpm  
 Av Air Con 4 cfm  
 Weight 0.92 kg  
 Vibration Level <2.5 m/sec<sup>2</sup>  
 Sound Pressure 76 db(a)  
 Length 159 mm  
 Height 154 mm  
 Max torque 62 lbs/ins (7 Nm)  
 Air Inlet 1/4 bsp

**UT8818-S**

**1/4" HEX DIRECT DRIVE SCREWDRIVER**

Comfortable, low-weight composite body



Speed 750 rpm  
 Av Air Con 4 cfm  
 Weight 0.92 kg  
 Vibration Level <2.5 m/sec<sup>2</sup>  
 Sound Pressure 76 db(a)  
 Length 159 mm  
 Height 154 mm  
 Max torque 115 lbs/ins (13 Nm)  
 Air Inlet 1/4 bsp

**UT5825-S**

**1/4" HEX DIRECT DRIVE SCREWDRIVER**

With cushion comfort grip



Speed 1,800 rpm  
 Av Air Con 4 cfm  
 Weight 1.36 kg  
 Vibration Level <2.5 m/sec<sup>2</sup>  
 Sound Pressure 91.0 db(a)  
 Length 156 mm  
 Height 140 mm  
 Max torque 30 lbs/ins (3.4 Nm)  
 Air Inlet 1/4 bsp

**UT2960A**

**ADJUSTABLE CLUTCH SCREWDRIVER**

Excellent for self-tapping

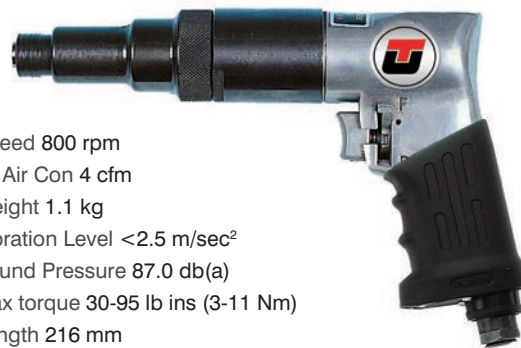

Speed 800 rpm  
 Av Air Con 4 cfm  
 Weight 1.1 kg  
 Vibration Level <2.5 m/sec<sup>2</sup>  
 Sound Pressure 87.0 db(a)  
 Max torque 30-95 lb ins (3-11 Nm)  
 Length 216 mm  
 Height 155 mm  
 Air Inlet 1/4 bsp

**UT2964A**

**ADJUSTABLE CLUTCH SCREWDRIVER**

Excellent for self-tapping

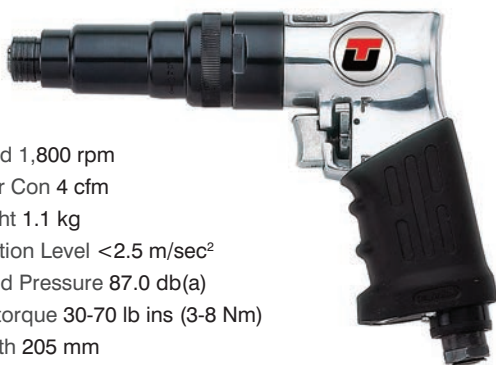

Speed 1,800 rpm  
 Av Air Con 4 cfm  
 Weight 1.1 kg  
 Vibration Level <2.5 m/sec<sup>2</sup>  
 Sound Pressure 87.0 db(a)  
 Max torque 30-70 lb ins (3-8 Nm)  
 Length 205 mm  
 Height 155 mm  
 Air Inlet 1/4 bsp

**UT5964A**

**1/4" HEX EXTERNAL ADJUSTABLE CLUTCH PISTOL SCREWDRIVER**

With cushion comfort grip

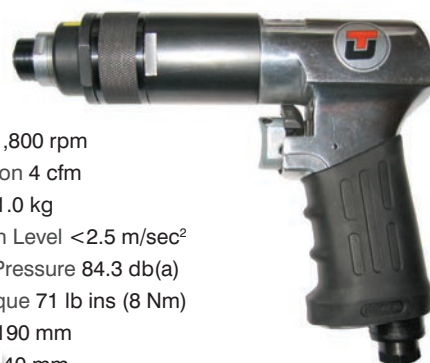

Speed 1,800 rpm  
 Av Air Con 4 cfm  
 Weight 1.0 kg  
 Vibration Level <2.5 m/sec<sup>2</sup>  
 Sound Pressure 84.3 db(a)  
 Max torque 71 lb ins (8 Nm)  
 Length 190 mm  
 Height 140 mm  
 Air Inlet 1/4 bsp

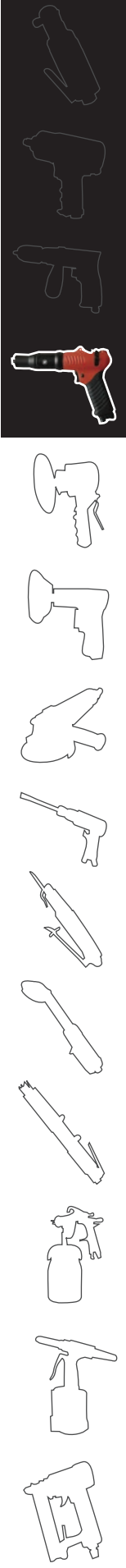



### UT8957

#### 1/4" HEX COMPOSITE PISTOL SCREWDRIVER

Push Start – Auto Shut-off



Speed 1,400 rpm  
 Av Air Con 4 cfm  
 Weight 0.95 kg  
 Vibration Level <2.5 m/sec<sup>2</sup>  
 Sound Pressure 72.0 db(a)  
 Torque Range 8.4-53 lbs ins (0.95-6 Nm)  
 Length 215 mm  
 Height 140 mm  
 Air Inlet 1/4 bsp

### UT8958

#### 1/4" HEX COMPOSITE PISTOL SCREWDRIVER

Push start – Auto shut off



Speed 1,000 rpm  
 Av Air Con 4 cfm  
 Weight 0.65 kg  
 Vibration Level <2.5 m/sec<sup>2</sup>  
 Sound Pressure 72.0 db(a)  
 Torque Range 4.5-31 lbs ins (0.5-3.5 Nm)  
 Length 180 mm  
 Height 140 mm  
 Air Inlet 1/4 bsp

### UT8959

#### 1/4" HEX COMPOSITE PISTOL SCREWDRIVER

Push start – Auto shut off



Speed 1,000 rpm  
 Avg Air Cons 4 cfm  
 Weight 0.65 kg  
 Vibration Level <2.5 m/sec<sup>2</sup>  
 Sound Pressure 72.0 db(a)  
 Max torque 10.6-66.5 lb ins (1.2-7.5 Nm)  
 Length 180 mm  
 Height 140 mm  
 Air Inlet 1/4 bsp

### UT8962

#### 1/4" HEX COMPOSITE PISTOL SCREWDRIVER

Push start – Auto shut off



Speed 300 rpm  
 Av Air Con 4 cfm  
 Weight 1.1 kg  
 Vibration Level < 2.5 m/sec<sup>2</sup>  
 Sound Pressure 76.4 db(a)  
 Max torque 26-180 lb ins (3-20 Nm)  
 Length 215 mm  
 Height 140 mm  
 Air Inlet 1/4 bsp

### UT8226

#### 1/4" HEX IMPACT SCREWDRIVER

With cushion comfort grip



Speed 9,500 rpm  
 Max Torque 200 ft/lbs (271 Nm)  
 Weight 1.38 kg  
 Vibration Level 4.7 m/sec<sup>2</sup>  
 Noise Level 88 db(a)  
 Length 165 mm  
 Av Air Con 3 cfm  
 Air Inlet 1/4 bsp

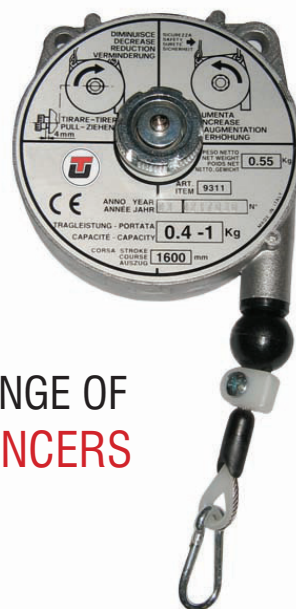

SEE OUR RANGE OF  
**TOOL BALANCERS**  
on page 49



**UT8955-1**  
STRAIGHT ADJUSTABLE  
CLUTCH SCREWDRIVER

Speed 1,800 rpm  
Max torque 85 lb ins (9.6 Nm)  
Av Air Con 4 cfm  
Weight 1.1 kg  
Vibration Level <2.5 m/sec<sup>2</sup>  
Sound Pressure 83.0 db(a)  
Length 228 mm  
Height 71 mm  
Air Inlet 1/4 bsp



**UT8905**  
1/4" HEX STRAIGHT  
SCREWDRIVER  
Push Start – Auto Shut-off

Speed 1,000 rpm  
Av Air Con 2 cfm  
Weight 0.43 kg  
Vibration Level <2.5 m/sec<sup>2</sup>  
Sound Pressure 72.0 db(a)  
Torque Range 0.45-1.77 lbs ins  
(0.05-0.2 Nm)  
Length 180 mm  
Height 35 mm  
Air Inlet 1/4 bsp



**UT8906**  
1/4" HEX STRAIGHT  
SCREWDRIVER  
Push Start – Auto Shut-off

Speed 800 rpm  
Av Air Con 2 cfm  
Weight 0.43 kg  
Vibration Level <2.5 m/sec<sup>2</sup>  
Sound Pressure 72.0 db(a)  
Torque Range 7-35 lbs ins (0.8-4 Nm)  
Length 180 mm  
Height 35 mm  
Air Inlet 1/4 bsp



**UT8956**  
1/4" HEX STRAIGHT  
SCREWDRIVER  
Push Start – Auto Shut-off

Speed 1,000 rpm  
Av Air Con 4 cfm  
Weight 0.77 kg  
Vibration Level <2.5 m/sec<sup>2</sup>  
Sound Pressure 78.0 db(a)  
Torque Range 8.8-62 lbs ins (1-7 Nm)  
Length 217 mm  
Height 42 mm  
Air Inlet 1/4 bsp



**UT8960-2**  
1/4" HEX ANGLE  
SCREWDRIVER  
Lever start – Auto shut off

Speed 700 rpm  
Av Air Con 4 cfm  
Weight 1.20 kg  
Vibration Level 1.3 m/sec<sup>2</sup>  
Sound Pressure 78.0 db(a)  
Torque Range 8.8-40 lbs ins (1-4.5 Nm)  
Length 320 mm  
Angle head Height 41 mm  
Air Inlet 1/4 bsp



**UT8961-2**  
1/4" HEX ANGLE  
SCREWDRIVER  
Lever start – Auto shut off

Speed 400 rpm  
Av Air Con 4 cfm  
Weight 1.3 kg  
Vibration Level 1.8 m/sec<sup>2</sup>  
Sound Pressure 78.0 db(a)  
Torque Range 44-88 lbs ins (5-10 Nm)  
Length 254 mm  
Angle head Height 47 mm  
Air Inlet 1/4 bsp

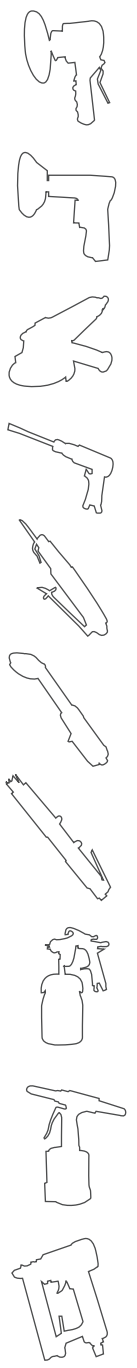



6

# SANDERS

## UT8708

### ORBITAL SANDER – CENTRAL VACUUM

Ergonomically designed, low vibration sander with compact shroud for optimal dust extraction and handling, delivering a high quality finish

Supplied with high quality velcro pad H0021V



DURABLE, LOW-WEIGHT  
COMPOSITE HOUSING

LOW VIBRATION FOR A  
SWIRL FREE FINISH

COMPACT DUST  
EXTRACTION SHROUD

INCLUDES HIGH QUALITY, LOW PROFILE,  
BALANCED SANDING PAD

Pad size 6" (152 mm)

Speed 10,000 rpm

Av Air Con 5 cfm

Weight 0.97 kg

Vibration Level <2.5 m/sec<sup>2</sup>

Sound Pressure 78 db(a)

Orbit 5 mm

Length 150 mm

Height 98 mm

Air Inlet 1/4 bsp

Thread 5/16



### UT8776KIT

#### 2" & 3" MINI SANDER KIT

Low noise, low weight, compact composite tool  
Supplied with 60 Sanding & 6 Surface Preparation Discs



Pad Size 2" & 3"  
Speed 20,000 rpm  
Av Air Con 3.5 cfm  
Weight 0.54 kg  
Vibration Level <2.5 m/sec<sup>2</sup>  
Sound Pressure 80 db(a)  
Length 100 mm  
Air Inlet 1/4 bsp

### UT3

#### D A SANDER NON VACUUM

Supplied with adhesive pad



Pad size 6" (152 mm)	Orbit 5 mm
Speed 10,000 rpm	Length 210 mm
Av Air Con 4 cfm	Height 130 mm
Weight 1.6 kg	Air Inlet 1/4 bsp
Vibration Level 5.1 m/sec <sup>2</sup>	Thread 5/16
Sound Pressure 86.8 db(a)	

### UT8709

#### 6" ORBITAL SANDER NON VACUUM

Supplied with velcro pad



Pad Size 6" (152 mm)	Orbit 5 mm
Speed 9,000 rpm	Length 250 mm
Av Air Con 5 cfm	Height 110 mm
Weight 1.25 kg	Air Inlet 1/4 bsp
Vibration Level <2.5 m/sec <sup>2</sup>	Thread 5/16
Sound Pressure 80 db(a)	

### UT2780-1

#### 6" D A SANDER

Supplied with velcro pad

UT2780-1DC  
Dust Collection  
supplied with  
velcro pad



Pad size 6" (152 mm)	Orbit 5 mm
Speed 10,000 rpm	Length 215 mm
Av Air Con 6 cfm	Height 130 mm
Weight 1.8 kg (UT8788DC 1.9 kg)	Air Inlet 1/4 bsp
Vibration Level <2.5 m/sec <sup>2</sup>	Thread 5/16
Sound Pressure 94.0 db(a)	

### UT8709DC

#### ORBITAL SANDER – CENTRAL VACUUM

Supplied with velcro pad



Pad size 6" (152 mm)	Orbit 5 mm
Speed 9,000 rpm	Length 280 mm
Av Air Con 5 cfm	Height 110 mm
Weight 1.3 kg	Air Inlet 1/4 bsp
Vibration Level <2.5 m/sec <sup>2</sup>	Thread 5/16
Sound Pressure 80.0 db(a)	

### UT8799V

#### 6" PALM SANDER-VACUUM

Velcro pad  
compact  
dust shrou



Pad Size 6" (152 mm)	Orbit 5 mm
Speed 12,000 rpm	Length 89 mm
Av Air Con 4 cfm	Height 93 mm
Weight 0.8 kg	Air Inlet 1/4 bsp
Vibration Level <3.5 m/sec <sup>2</sup>	Thread 5/16
Sound Pressure 88.5 db(a)	

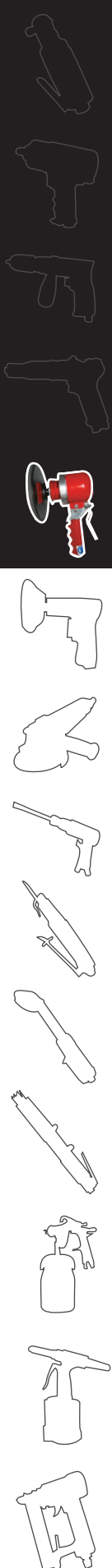



### UT010

#### STRAIGHT LINE SANDER

Replacement velcro pad pkt of 5 010-VS

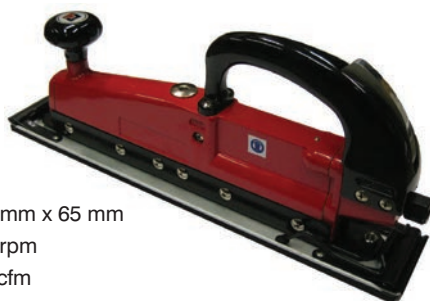

Pad size 400 mm x 65 mm  
 Speed 3,000 rpm  
 Av Air Con 7 cfm  
 Weight 3.1 kg  
 Vibration Level 13.9 m/sec<sup>2</sup>  
 Sound Pressure 90.4 db(a)  
 Air Inlet 1/4 bsp

### UT8794

#### BLOCK SANDER NON VACUUM

Supplied with adhesive pad

Replacement backing pad 729374



Pad size 170mm x 90mm	Sound Pressure 85.4 db(a)
Speed 8,500 rpm	Orbit 4.8 mm
Av Air Con 4 cfm	Length 165 mm
Weight 2.2 kg	Height 110 mm
Vibration Level 3.3 m/sec <sup>2</sup>	Air Inlet 1/4 bsp

### UT8795/UT8795DC

#### BLOCK SANDER NON VACUUM/ CENTRAL VACUUM

Supplied with velcro pad as standard also fitted with paper clips

Replacement backing pads UT-BTL4-40V non-vacuum & UT-BTL4-40V-4 vacuum

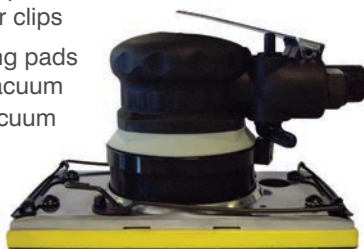

Pad Size 180 x 100 mm	Sound Pressure 80 db(a)
Speed 8,500 rpm	Orbit 3.2 mm
Av Air Con 5 cfm	Length 180 mm
Weight 1.2 kg	Height 104 mm
Vibration Level <2.5 m/sec <sup>2</sup>	Air Inlet 1/4 bsp

### UT9764

#### 10MM BELT SANDER

For replacement belts see page 26



Belt Size 328 x 10 mm  
 Speed 25,000 rpm  
 Av Air Con 6 cfm  
 Weight 0.9 kg  
 Vibration Level <2.5 m/sec<sup>2</sup>  
 Sound Pressure 85 db(a)  
 Length 260 mm  
 Height 170 mm  
 Air Inlet 1/4 bsp

### UT9765

#### 20MM BELT SANDER

For replacement belts see page 26



Belt Size 525 x 20 mm  
 Speed 16,000 rpm  
 Av Air Con 6 cfm  
 Weight 1.15 kg  
 Vibration Level <2.5 m/sec<sup>2</sup>  
 Sound Pressure 85 db(a)  
 Length 347 mm  
 Height 95 mm  
 Air Inlet 1/4 bsp

### UT9704

#### 30MM BELT SANDER

For replacement belts see page 26



Belt size 540 mm x 30 mm  
 Speed 12,000 rpm  
 Av Air Con 6 cfm  
 Weight 2.30 kg  
 Vibration Level 3.1 m/sec<sup>2</sup>  
 Sound Pressure 84.0 db(a)  
 Length 495 mm  
 Height 95 mm  
 Air Inlet 1/4 bsp





## UT5766

### 60MM BELT SANDER

Ideal for sanding wood, plastic, glass or metal products

For replacement belts see page 26



Belt Size 260 x 60 mm  
Speed 7,000 rpm  
Weight 1.1 kg  
Vibration Level 2.08 m/sec<sup>2</sup>  
Sound Level 89 db(a)  
Air Inlet 1/4 bsp

## UT8749S

### 5" ANGLE SANDER



Pad size 5" (125 mm)  
Speed 9,000 rpm  
Av Air Con 7 cfm  
Weight 1.8 kg  
Vibration Level <2.5 m/sec<sup>2</sup>  
Sound Pressure 84.1 db(a)  
Length 280 mm  
Height 99 mm  
Spindle Size 5/8 unc  
Air Inlet 1/4 bsp

## UT8756-1

### 7" ANGLE SANDER



Speed 4,500 rpm  
Av Air Con 8 cfm  
Weight 2.3 kg  
Vibration Level <2.5 m/sec<sup>2</sup>  
Sound Pressure 95.7 db(a)  
Pad size 7" (178 mm)  
Length 315 mm  
Height 47 mm  
Spindle Size 5/8" unc  
Air Inlet 1/4 bsp

## UT8771A

### HIGH SPEED SANDER

Replacement sanding discs:  
3" 729730, 4.5" 729731 & 5.5" 72732  
3", 4.5" & 5.5" Set H0065



Pad sizes 75, 115 & 140 mm  
Speed 15,000 rpm  
Av Air Con 6 cfm  
Weight 1.1 kg  
Vibration Level <2.5 m/sec<sup>2</sup>  
Sound Pressure 84.0 db(a)  
Length 107 mm  
Height 132 mm  
Spindle Size 7/16"  
Pad Hole Size 7/16" x 20 unf  
Air Inlet 1/4 bsp

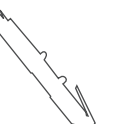
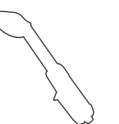



CONTENTS:

- 1 x UT8777 C grinder with 6mm collet
- 5 x 3" polishing discs H308K014
- 5 x 2" polishing discs H308K012
- 5 x 3" sanding discs H308K013
- 5 x 2" sanding discs H308K011
- 5 x 6mm mounted points\* plus
- 5 x 3mm mounted points\* H308K008
- 1 x 3mm collet 732224
- 16 x sanding belts\* H308K010
- 1 x 2" backing pad 0308C025
- 1 x 3" backing pad H308K007
- 1 x 2" backing pad arbor plus
- 1 x 3" backing pad arbor H308K003
- 1 x spanner 11" H308K004
- 1 x spanner 17" H308K005
- 4 x roller belt holders\* H308K009

Ready for use with Roloc bristle discs see UT8777

\*These items are available in packs and are not sold separately



UT8777CBK

SMART REPAIR TOOL KIT

- Pad size 2" (50mm) / 3" (75mm)
- Speed 25,000 rpm
- Av Air Con 4 cfm
- Weight 0.6 kg
- Vibration Level <2.5 m/sec<sup>2</sup>
- Sound Pressure 84.7 db(a)
- Tool Length 135 mm
- Tool Height (Angle Head) 93 mm
- Collet Size 6 mm
- Air Inlet 1/4 bsp

UT8777

SMART REPAIR TOOL

Supplied with one Green (50 grit) bristle disc



- Pad size 2" (50 mm)
- Speed 25,000 rpm
- Av Air Con 4 cfm
- Weight 0.6 kg
- Vibration Level <2.5 m/sec<sup>2</sup>
- Sound Pressure 84.7 db(a)
- Length 135 mm
- Height (Angle Head) 93 mm
- Spindle Size 1/4 - 20 unf
- Air Inlet 1/4 bsp

SANDER ACCESSORIES



BRISTLE DISCS



SANDING DISCS



BACKING PADS



SURFACE CONDITIONING DISCS



BELTS

Sander Belts – Pack of 10	Part No.
10mm (for UT8764, UT5764 & UT9764)	8764 + grit size
Grit size: 40, 50, 60, 80, 100, 120 & 150	
20mm (for UT8765, UT5765 & UT9765)	8765 + grit size
Grit size: 40, 50, 60, 80, 100, 120 & 150	
30mm (for UT8704 & UT9704)	8704 + grit size
Grit size: 40, 50, 60, 80, 100 & 120	
60mm (for UT5766)	5766 + grit size
Grit Sizes available: 40, 60, 80, 100, 120, 150, 180	

CONSUMABLES FOR UT8777 & UT8777CBK	2" Bristle discs	
	20004 Green (50 grit)	

2" & 3" Sanding Discs (packs of 10)	2"		3"	
Black 24 grit	HO-P24		HO-P24-3	
Brown 36 grit	HO-P36		HO-P36-3	
Green 50 grit	HO-P50		HO-P50-3	
Yellow 80 grit	HO-P80		HO-P80-3	
White 120 grit	HO-P120		HO-P120-3	

2" & 3" Surface Conditioning Discs	2"		3"	
Fine	HOSCF		HOSCF3	
Medium	HOSCM		HOSCM3	
Coarse	HOSCC		HOSCC3	

CONSUMABLE SPARE PARTS FOR BELT SANDERS

	10mm UT5764	20mm UT5765	10mm UT8764	20mm UT8765	30mm UT8704
Idle Pulley Assembly	5764002	0707002D/E/F	900539	900647	900712
Bearings (2 req'd)	Included	Included	900540	900648	900713
Collar	None	Included	None	900650	900714
Pulley pin	5764004	Included	900541	900649	900715

6" Backing pads

H0018V	Velcro	no holes
H0021V7	Velcro	7 holes
H0021V15	Velcro	15 holes
H0021	Sticky	no holes
H0021D	Sticky	6 holes

3" Backing pads

8705-PAD	Velcro	no holes
8705DC-PAD	Velcro	3 holes



# 7

# POLISHERS

## UT8780K

### 3" MINI POLISHING KIT

Speed 3,200 rpm

Pad Size 3" (75 mm)

Av Air Con 3.2 cfm

Weight 0.72 kg

Vibration Level 0.77 m/sec<sup>2</sup>

Sound Level 80 db(a)

Length 115 mm

Air Inlet 1/4 bsp

#### Contents:

3" Mini Polisher

3" Velcro Sanding Pad

3 1/2" Bonnet

3 1/2" Yellow Compounding Pad

3 1/2" White Compounding Pad

SA-6003V-3P

SA-77213

SA-75543VC

SA-75653VC



DURABLE, LOW WEIGHT  
COMPOSITE MOTOR HOUSING

EASILY ADJUSTABLE  
POWER REGULATOR

TWO-FINGER TRIGGER FOR  
COMFORTABLE OPERATION

COMPACT PISTOL GRIP  
FOR MAXIMUM CONTROL  
AND MANOEUVRABILITY

LOW NOISE  
REAR EXHAUST

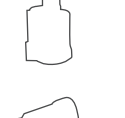
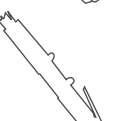
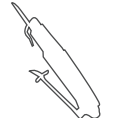

Information, orders & expert advice: Call 01494 883300 | Email [sales@universal.co.uk](mailto:sales@universal.co.uk)



### UT8752

#### 7" ANGLE POLISER

Complete with lambswool mop (H0067)



Speed 2,100 rpm  
 Av Air Con 8 cfm  
 Weight 2.3 kg  
 Vibration Level <math><2.5\text{ m/sec}^2</math>  
 Sound Pressure 97.0 db(a)  
 Pad size 7" (178 mm)  
 Length 315 mm  
 Height 47 mm  
 Spindle Size 5/8" unc  
 Air Inlet 1/4 bsp

### UT8841-SM

#### SISAL POLISHING MACHINE



Speed 3,600 rpm  
 Av Air Con 3.7 cfm  
 Weight 0.8 kg  
 Vibration Level 3.6 m/sec<sup>2</sup>  
 Sound Pressure 86.0 db(a)  
 Length 253 mm  
 Height 37 mm  
 Spindle Size 3/8 x 24  
 Air Inlet 1/4 bsp

### POLISER ACCESSORIES

#### SISAL MOPS, POLISING MOPS, BACKING PADS & ACCESSORIES

- 7" lambs wool bonnet (UT8744 & UT8752)
- 8" lambs wool bonnet (UT8744 & UT8752)
- Compounding mop (UT8744 and UT8752)
- Sisal mop wheel - length 80mm (UT8841SM)
- Sisal mop adaptor (UT8841SM)

- Part No.
- H0067
- H0068
- H0087
- H0107
- 270-45

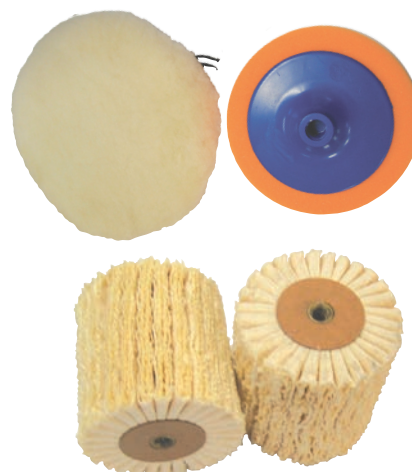

# 8

## GRINDERS

### UT8740

INDUSTRIAL ANGLE GRINDERS WITH LOW VIBRATION SIDE HANDLE

SPINDLE LOCK FOR QUICK DISC CHANGE

REAR EXHAUST

COMPOSITE MOTOR HOUSING

SAFETY THROTTLE LEVER

COMFORTABLE SIDE HANDLE HELPS TO ABSORB VIBRATION ON THE SUPPORT HAND

9 POSITION ADJUSTABLE SWIVEL GUARD

ALSO AVAILABLE WITH DUST EXTRACTION

Speed 10,000 rpm  
Av Air Con 4 cfm  
Weight 2 kg  
Vibration Level 1.2 m/sec<sup>2</sup>  
Sound Level 83 db(a)  
Motor Output 0.75 hp  
Length 238 mm  
Air Inlet 1/4 bsp

**UT8740A10** 4" ANGLE GRINDER WITH M10 SPINDLE

**UT8740A14** 4" ANGLE GRINDER WITH M14 SPINDLE

**UT8740B14** 4 1/2" ANGLE GRINDER WITH M14 SPINDLE

**UT8740C14** 5" ANGLE GRINDER WITH M14 SPINDLE

**8740EH** EXHAUST HOSE FOR ALL ABOVE MODELS

Information, orders & expert advice: Call 01494 883300 | Email [sales@universal.co.uk](mailto:sales@universal.co.uk)

29



**UT8750-T**  
4" ANGLE GRINDER



Speed 12,000 rpm	Length 229 mm
Av Air Con 13.2 cfm	Height 135 mm
Weight 1.8 kg	Spindle Size M10
Vibration Level <2.5m/sec <sup>2</sup>	Air Inlet 1/4 bsp
Sound Pressure 84.0 db(a)	

**UT8779A**  
4" LIGHTWEIGHT GRINDER

With cushion comfort grip



Speed 15,000 rpm  
Av Air Con 6 cfm  
Weight 1.37 kg  
Vibration Level <2.5m/sec<sup>2</sup>  
Sound Pressure 84.0 db(a)  
Length 110 mm  
Height 135 mm  
Spindle Size 7/16 x 20 unf  
Air Inlet 1/4 bsp

**UT9750 /UT9750A/UT9750B**  
4", 4-1/2" & 5"  
UT9750 comes with M10 spindle  
UT9750A/B comes with M14 spindle

All models Available with dust extraction



Speed 11,000 rpm	Length 200 mm
Av Air Con 4 cfm	Height 50 mm
Weight 1.6 kg	Spindle Size M10/M14
Vibration Level 1.20 m/sec <sup>2</sup>	Air Inlet 1/4 bsp
Sound Pressure 83 db(a)	

**UT8766**  
1.7HP 7" ANGLE GRINDER



Speed 7,500 rpm	Length 318 mm
Av Air Con 7.0 cfm	Height 135 mm
Weight 3.1 kg	Spindle Size M14
Vibration Level <2.5m/sec <sup>2</sup>	Air Inlet 3/8 bsp
Sound Pressure 84.0 db(a)	

**UT8777C**  
ANGLE DIE GRINDER

Collet sizes available 1/8", 1/4", 3mm, 6mm & 8mm  
Also available as part of the Smart Repair Tool kit, see page 33



Speed 25,000 rpm  
Collet size 6 mm  
Av Air Con 4 cfm  
Weight 0.6 kg  
Vibration Level <2.5 m/sec<sup>2</sup>  
Sound Pressure 84.7 db(a)  
Length 135 mm  
Height (Angle head) 93 mm  
Air Inlet 1/4 bsp

**UT5715**  
90° ANGLE DIE GRINDER WITH COMFORT GRIP

Collet sizes available 1/8", 1/4", 3mm, 6mm & 8mm



Speed 22,000 rpm  
Collet size 6 mm  
Av Air Con 4 cfm  
Weight 0.50 kg  
Vibration Level <2.5 m/sec<sup>2</sup>  
Sound Pressure 86.0 db(a)  
Length 140 mm  
Height (Angle head) 75 mm  
Air Inlet 1/4 bsp

**UT8724-20****ANGLE DIE GRINDER**

Collet sizes available  
1/8", 1/4", 3mm,  
6mm & 8mm



Speed 20,000 rpm  
Motor Power 0.45 hp  
Collet size 6 mm  
Vibration Level 2.4 m/sec<sup>2</sup>  
Sound Level 78 db(a)  
Length 165 mm  
Weight 0.5 kg  
Air Inlet 1/4 bsp

**UT919C****9" VERTICAL GRINDER**

Speed 6,000 rpm  
Av Air Con 14 cfm  
Weight 5.8 kg  
Vibration Level 4.9 m/sec<sup>2</sup>  
Sound Pressure 89.7 db(a)

Motor Output 6 hp  
Length 300 mm  
Height 222 mm  
Spindle Size 5/8" unc  
Air Inlet 1/2 bsp

**UT5735****EXTENDED DIE GRINDER**

Collet sizes available  
1/8", 1/4", 3mm,  
6mm & 8mm



Speed 25,000 rpm  
Collet size 6 mm  
Av Air Con 4 cfm  
Weight 0.66 kg  
Vibration Level <2.5 m/sec<sup>2</sup>  
Sound Pressure 91.0 db(a)  
Motor Output 0.5 hp  
Length 255 mm  
Height 37 mm  
Air Inlet 1/4 bsp

**UT8728E****STRAIGHT EXTENDED DIE GRINDER**

0.9 HP motor for extra  
stall resistance

1/8", 1/4", 3mm & 6mm available on request

Speed 22,000 rpm  
Collet Size 8 mm  
Av Air Con 5.5 cfm  
Weight 1.1 kg  
Vibration Level 2.12 m/sec<sup>2</sup>  
Sound Pressure 83.7 db(a)  
Motor Output 0.9 hp  
Length 305 mm  
Height 42 mm  
Air Inlet 1/4 bsp

**UT5710B****MINI DIE GRINDER**

Collet sizes available 1/8", 1/4",  
3mm, 6mm & 8mm



Speed 25,000 rpm  
Collet size 6 mm  
Av Air Con 3 cfm  
Weight 0.38 kg  
Vibration Level <2.5 m/sec<sup>2</sup>  
Sound Pressure 86.0 db(a)  
Length 148.5 mm  
Height 40 mm  
Air Inlet 1/4 bsp

**UT5720B****DIE GRINDER**

With cushion comfort grip

Collet sizes available 1/8", 1/4",  
3mm, 6mm & 8mm

Speed 25,000 rpm  
Collet size 6 mm  
Av Air Con 3.5 cfm  
Weight 0.6 kg  
Vibration Level 1.57 m/sec<sup>2</sup>  
Sound Pressure 78.4 db(a)  
Length 178 mm  
Height 43 mm  
Air Inlet 1/4 bsp





## UT5721

### DIE GRINDER

Collet sizes available 1/8", 1/4", 3mm, 6mm & 8mm

Speed 20,000rpm  
Motor Power 0.5hp  
Collet size 6mm  
Av Air Con 4 cfm  
Vibration Level 3m/sec<sup>2</sup>  
Sound Level 93db(a)  
Length 170mm  
Weight 0.6kg  
Air Inlet 1/4 bsp



## UT8841-DG

### DIE GRINDER

Collet sizes available 1/8", 1/4", 3mm, 6mm & 8mm

Speed 3,600 rpm  
Motor Power 0.5 hp  
Av Air Con 3.7 cfm  
Weight 0.8 kg  
Vibration Level 3.6 m/sec<sup>2</sup>  
Sound Pressure 86.0 db(a)  
Length 273 mm  
Height 37 mm  
Collet Size 3/8 x 24  
Air Inlet 1/4 bsp



## UT8724

### 6MM DIE GRINDER

0.45 HP motor prevents stall under load

Collet sizes available 1/8", 1/4", 3mm, 6mm & 8mm

Speed 20,000 rpm  
Motor Power 0.45 hp  
Collet size 6mm  
Vibration Level 3.5 m/sec<sup>2</sup>  
Sound Level 78 db(a)  
Length 165 mm  
Weight 0.5 kg  
Air Inlet 1/4 bsp



## UT5721-TB

### TYRE BUFFER

See page 26 for accessories

Speed 20,000 rpm  
Motor Power 0.5 hp  
Collet size 6 mm  
Av Air Con 4 cfm  
Vibration Level 3 m/sec<sup>2</sup>  
Sound Level 93 db(a)  
Length 170 mm  
Weight 0.6 kg  
Air Inlet 1/4 bsp



## UT8707K

### ANGLE HEAD TURBINE GRINDER KIT

Roll throttle and small diameter grip for constant speed and operator control

Speed 70,000 rpm  
Av Air Con 5.7 cfm  
Weight 0.20 kg  
Vibration Level 1.8 m/sec<sup>2</sup>  
Sound Pressure 88 db(a)  
Length 150 mm  
Height 20 mm  
Air Inlet 1/4 bsp



## UT8706K-2

### 1/8" PENCIL GRINDER KIT

Double front spindle bearing for increased durability and reduced vibration

This model is replacing UT/UK UT1070K

Speed 54,000 rpm  
Av Air Con 4 cfm  
Weight 0.2 kg  
Vibration Level <2.5 m/sec<sup>2</sup>  
Sound Pressure 72.0 db(a)  
Length 133 mm  
Height 20 mm  
Angle Head Height 45 mm  
Air Inlet 1/4 bsp



Collet sizes are 3/32, 1/8, & 3mm





## UT8775-ABK

### MULTI FUNCTION GRINDER

Supplied in a kit with the accessories shown  
Optional Dust Extraction - UT875VA

Speed 4,000 rpm

Av Air Con 4 cfm

Weight 1.2 kg

Vibration Level <math>< 2.5 \text{ m/sec}^2</math>

Sound Pressure 81 db(a)

Length 270 mm

Height 100 mm

Air Inlet 1/4 bsp



## UT8716-BKC

### 2" MINI GRINDER & CUTTER KIT

10 cutting & grinding wheels included

Speed 18,000 rpm

Av Air Con 4 cfm

Weight 0.6 kg

Vibration Level 8.5 m/sec<sup>2</sup>

Sound Pressure 81 db(a)

Length 125 mm

Height 60 mm

Spindle Size 3/8" x 24 unc

Air Inlet 1/4 bsp

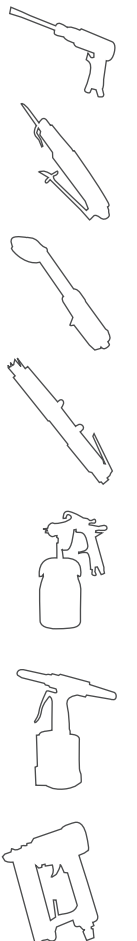



### COLLETS



Collet size	Part No. for all Die Grinders*	UT5724 Only	UT5725 Only	UT1070K Only
3/32"	-	-	-	-
1/8"	92232	5724-22B	5724-15B	RL81202A
1/4"	92253	5724-22A	5725-15A	-
1mm	-	-	-	RL81202C
3mm	732224	5724-22C	5725-15C	RL81202B
6mm	732227	5724-22	5725-15	-
8mm	RL80528G	-	5725-15D	-

\*Please use the table above to ensure you select the correct collet for your tool  
More tool collets are available on request

### 2" CUTTING & GRINDING DISCS

For use with UT8716BKC	Part No.
Grinding	
60 grit	5A-7283A39-11
80 grit	5A-7283A39-12
120 grit	5A-7283A39-13
Cutting	H0070



### SPARES FOR UT8775ABK



Stripping Wheel  
ST-BT246652



Eraser Wheel  
ST-BTRE115-30



Eraser Adaptor  
ST-BT246655A-K03A



Fine Wire Bristles	BTWW103-23-5
Medium Wire Bristles	BTWW103-23-5.5
Coarse Wire Bristles	BTWW103-23-7

### TYRE BUFFER

	Part No.
Assembly (cone and arbor) (fits all die grinders and drills)	H0036
Replacement cone only	H0037

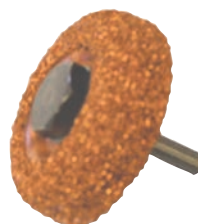



# 9

# HAMMERS

## UT9925BK

### PISTOL RECOILLESS AIR HAMMER KIT

Kit contains five chisels: 902, 907, 909, 910, 912 (see page 37)

Includes H0045B non-turn quick change retainer and 512 standard spring retainer

Tool also available separately with standard spring retainer, part number UT9925

Shank size .401

Blows per min 3,700

Av Air Con 4 cfm

Weight 1.95 kg

Vibration Level 2.35 m/sec<sup>2</sup>

Sound Pressure 94.26 db(a)

Length 152 mm

Height 144 mm

Air Inlet 1/4 bsp



## UT8646-1/UT8646-1BK

### PISTOL AIR HAMMER

Impact resistant composite handle for reduced weight

Kit contains 5 chisels and standard spring retainer



Shank size .401

Blows per min 3,700

Av Air Con 4 cfm

Weight 1.1 kg

Vibration Level 13.8 m/sec<sup>2</sup>

Sound Pressure 96.3 db(a)

Length 152 mm

Height 145 mm

Air Inlet 1/4 bsp

## UT8663/UT8664

### AERO RIVETING HAMMER



Shank size .401

Blows per min (UT8663) 2160 (UT8664) 1740

Av Air Con 7.8 cfm

Weight (UT8663) 1.3 (UT8664) 1.4 kg

Vibration Level (UT8663) 5.6 (UT8664) 5.8 m/sec<sup>2</sup>

Sound Pressure (UT8663) 91.5 (UT8664) 91.7 db(a)

Length (UT8663) 170 (UT8664) 227 mm

Height 140 mm

Air Inlet 3/8 bsp





### UT8674-1 PISTOL AIR HAMMER

3/4" piston, 4-5/8" stroke and 0.498" shank for extra heavy duty work  
Kit is available on request

Shank size .498  
Blows per min 3,200  
Av air con 7.8 cfm  
Weight 1.9 kg  
Vibration level 6.8 m/sec<sup>2</sup>  
Sound pressure 92.5 db(a)  
Length 198 mm  
Height 150 mm



### UT8654H4 4" STROKE CHIPPING HAMMER

Crisp plate valve for extra hard hitting and control

Shank size .580 hex  
Blows per min 1,700  
Av air con 8.3 cfm  
Weight 8.9 kg  
Vibration level 6.7 m/sec<sup>2</sup>  
Sound pressure 92.5 db(a)  
Length 419 mm  
Height 150 mm



### UT8631BK

#### CHIPPING HAMMER KIT WITH NEEDLE SCALER ATTACHMENT

Supplied in a case with 3 chisels and a needle scaler attachment

Includes needle set (19 x 3mm flat) part no. 1377

For chisels see page 37

Blows per min 4,400	Sound Pressure 90.3 db(a)
Shank Size 1/2 sq	Length 210 mm
Av Air Con 4 cfm	Height 43 mm
Weight 2.7 kg	Air Inlet 1/4 bsp
Vibration Level 14.5 m/sec <sup>2</sup>	





**CHISELS**

	.401 Shank	.401 Non Turn	.498 Shank
Universal Joint and Tie Rod Tool	901	-	965
Tail Pipe Cutter	902	3114	-
Fork Chisel	903-3/4 (3/4") 903-1 (1")	-	968-(1/4")
Bushing Removal Chisel	904	-	-
Wide Chisel and Scraper 11/4" Blade	905	3106	955
Bushing Splitter	906	-	964
Claw Ripper-Edging Tool	907	3105	-
Muffler Cutter	908	-	-
Panel Cutter	909	3109	959
Flat Chisel, 3/4" Blade x 7" long	910	3102	960-5/8
Flat Chisel 11" O.A.L. 3/4" Blade	910-11	3102-12 12" O.A.L.	-
Flat Chisel 18" O.A.L. 3/4" Blade	910-18	3102-18	960-18
Flat Chisel, 1/2" Blade x 7" long	910-1/2	-	-
Flat Chisel, 1 1/2" Blade x 7" long	910-11/2	-	-
Tapered Punch	911	3110	961
Rivet Cutter	912	3103	962
Straight Punch	913	3101	963
Vee Chisel	914	-	-
Spoon Chisel	922	3112	-
Single Edge Cutter	923	3104	-
1" Smoothing Hammer	H0096 (945)	-	H0098 (967)
Inside Muffler Cutter	933	-	-
Outside Muffler Cutter	934	-	-
Moil Point	940	-	-
1" Smoothing Hammer (7")	945-7	-	-
Goo Scraper	951	-	-
13/4" Smoothing Hammer	H0097	-	-
Round Rivet Snap 3/16	1604	-	-
Round Rivet Snap 1/4	1605	-	-
Round Rivet Snap 5/16	1606	-	-

to fit UT3X/4X/7X/UT049/UT8612 & UT8612LV

**WELD CHIPPER CHISELS**

	1/2"sq	UT8630 Type A Shank	UT8631 Type B Shank
Blank		391	395
Chisel		392	396
Chisel - Wide		393	397
Chisel Angle		394	398
Scaper		390	399
Diamond		3230	3224
Round Nose		3231	3225
Cape		3232	3226
Panel Cutter		3241	3201

To fit UT8631, see page 36

**HEAVY HAMMER CHISELS - OVAL COLLAR**

	Round Shank	Hex Shank
Blank - 8"	301	302
Flat - 9"	303	304
MoilPoint - 9"	313	314
Wide Flat - 1 1/2 - 9"	325	326
Wide Flat - 2 - 9"	323	324
Cape - 9"	305	306
Round Nose - 9"	307	308
Diamond - 9"	309	310
Gouge - 9"	337	338

To fit UT8644H/ UT8654H4  
\*Round collar versions are available on request.

**CHISEL RETAINERS**

	Part Number
Standard spring retainer (.401")	512
Pack of 10 (.401")	512-10
Standard spring retainer (.498")	513
Beehive spring (.498")	898
Standard non-turn retainer (.401")	H0045B





10

## AIR SAWS

HIGH SPEED BI-METAL SAW BLADES

PART NO. H0403-18 - 18 TPI  
H0403-24 - 24 TPI  
H0403-32 - 32 TPI

### UT5922LV

#### LOW VIBRATION AIR SAW

Exceptionally low vibration for greater operator comfort and maximum trigger time

Av Air Con 4 cfm

Weight 0.55 kg

Vibration Level 1.2 m/sec<sup>2</sup>

Sound Level 85 db(a)

Strokes Per Min 10,000

Length 265 mm

Air Inlet 1/4 bsp



SAFETY THROTTLE LEVER

LOW VIBRATION AND COMFORTABLE NON-SLIP GRIP

SMALL AND LOW WEIGHT DESIGN FOR GREAT ACCESSIBILITY

ADJUSTABLE 360° REAR EXHAUST



**UT5920**  
ECONOMY AIR SAW



Av Air Con 4 cfm  
Weight 0.6 kg  
Vibration Level 24.1 m/sec<sup>2</sup>  
Sound Pressure 79 db(a)  
Strokes per min 10,000  
Capacity in steel 1.6 mm  
Capacity in aluminium 2.0 mm  
Length 199 mm  
Height 40 mm  
Air Inlet 1/4 bsp

**HP020**  
JIGSAW



Av Air Con 8 cfm	Capacity in steel 10 mm
Weight 1.8 kg	Capacity in wood 60 mm
Vibration Level 4.0 m/sec <sup>2</sup>	Length 225 mm
Sound Pressure 76.0 db(a)	Height 206 mm
Strokes per min 1,600-3000	Air Inlet 1/4 bsp

**SAW BLADES**

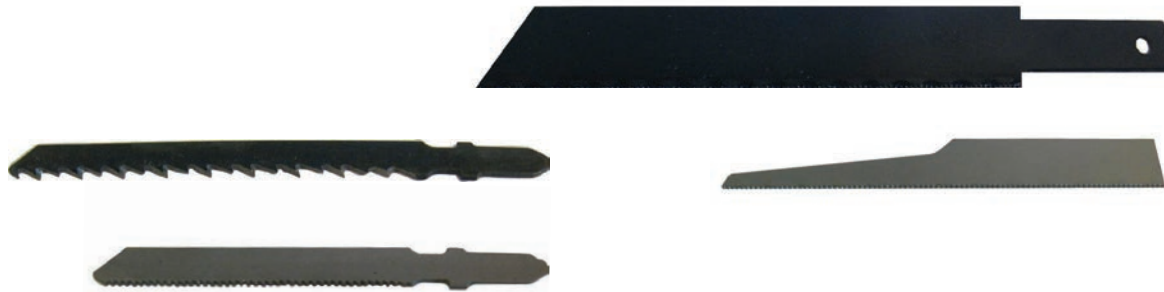

**JIGSAW BLADES**  
(FOR HP020)

Set of 5 general purpose blades (wood, plastics etc.)	Part No. H0400
Set of 5 blades suitable for metal/sheet metal	H0401

**BI-METAL SAW BLADES**  
(FOR UT5920 & UT5922LV)

18 TPI	Part No. H0403-18
24 TPI	H0403-24
32 TPI only sold singles	H0403-32
CSB 24 and CSB32 are sold in pkts of 5	





# 11

## CUTTING TOOLS



PUSH TO ADJUST GUARD

LOW PROFILE HEAD ONLY 49MM

SPINDLE LOCK

### UT5761A

#### EXTENDED CUT OFF TOOL

Low profile head brings 1HP of cutting power into extremely tight spaces  
Easily adjustable 11-point variable guard  
Spindle lock for quick disc change

120° ADJUSTABLE SWIVEL GUARD

Speed 14,000 rpm

Power Output 1.0 hp (0.7 kw)

Cutting Disc Size 4" (100 mm)

Disc Hole Size 3/8" (10 mm)

Av Air Con 4 cfm

Length 377 mm

Head Width 49 mm

Nett Weight 1.7 kg

Vibration Level 3.65 m/sec<sup>2</sup>

Sound Pressure 89.5 db(a)

Air Inlet 1/4 bsp

COMFORT GRIP

SAFETY THROTTLE LEVER

REAR EXHAUST





**UT8600-1**

**NIBBLER**

Complete with spare punch and die

Av Air Con 4 cfm  
 Weight 0.93 kg  
 Vibration Level 4.0 m/sec<sup>2</sup>  
 Sound Pressure 87.0 db(a)  
 Strokes per min 3,500  
 Capacity in steel 1.0 mm  
 Capacity in aluminium 2.0 mm  
 Length 193 mm  
 Height 105 mm  
 Air Inlet 1/4 bsp



**UT8841-S**

**STRAIGHT SHEAR**

Powerful 0.5 HP motor

Speed 3,600 rpm  
 Motor Power 0.5 hp  
 Av Air Con 3.7 cfm  
 Weight 0.8 kg  
 Vibration Level 3.6 m/sec<sup>2</sup>  
 Sound Pressure 86.0 db(a)  
 Capacity in steel 1.6 mm  
 Capacity in aluminium 2.0 mm  
 Length 273 mm  
 Height 37 mm  
 Air Inlet 1/4 bsp



**UT8606**

**PISTOL SHEAR**

Powerful 0.5 HP motor with tease trigger

Speed 2,600 rpm  
 Motor Power 0.5 hp  
 Av Air Con 3.7 cfm  
 Weight 0.9 kg  
 Vibration Level 1.2 m/sec<sup>2</sup>  
 Sound Pressure 91.0 db(a)  
 Capacity in steel 1.6 mm  
 Capacity in aluminium 2.0 mm  
 Length 226 mm  
 Height 125 mm  
 Air Inlet 1/4 bsp



**UT5762**

**CUT-OFF TOOL**

Clear Polycarbonate Swivel Guard  
 Includes cutting disc

Speed 20,000 rpm  
 Motor 0.5 hp  
 Cutting Disc Size 3 mm (75 mm)  
 Weight 0.6 kg  
 Vibration Level 3 m/sec<sup>2</sup>  
 Noise Level 93 db(a)  
 Length 171 mm  
 Av Air Con 4.5 cfm  
 Air Inlet 1/4 bsp



**CUTTING TOOL ACCESSORIES**



Nibbler punch for UT8600-1  
 Nibbler die (anvil) for UT8600-1



UT8600-1-38 Complete shear head for  
 UT8600-1-40 UT8606 and UT8841-S HA10



2" Cutting Disc for UT8716BKC H0070  
 3" Cutting Disc for UT5762 H0069N  
 4" Cutting Disc for UT5761A 5L-3011B39N

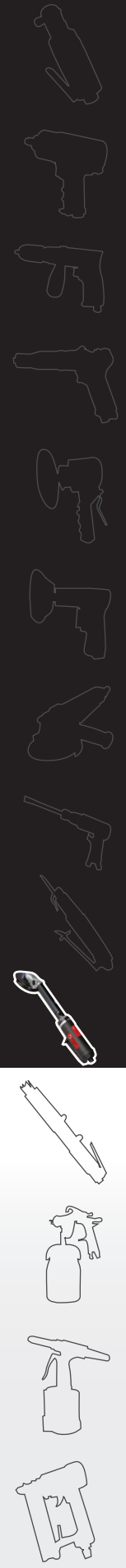



# 12

# NEEDLE SCALERS

NEW RANGE OF ATEX APPROVED NEEDLE SCALERS AVAILABLE ON REQUEST



## HP003LV

**LOW VIBRATION  
HEAVY DUTY  
PISTOL NEEDLE SCALER**

Includes needle set (28 x 3 mm)  
part no.317

Low vibration pistol grip needle scaler  
for heavy duty applications

Reduced risk of vibration related  
injuries and improves operator control

No additional tools needed for  
changing needles

- Blows per min 3,000
- Standard needle set 28 (3 mm)
- Av Air Con 8.5 cfm
- Weight 3.5 kg
- Vibration Level 2.3 m/sec<sup>2</sup>
- Sound Pressure 95.06 db(a)
- Length 370 mm
- Height 177 mm
- Air Inlet 1/4 bsp

## HP002LV

**LOW VIBRATION MEDIUM DUTY  
STRAIGHT NEEDLE SCALER**

Includes needle set (19 x 3 mm) part no.225

- Blows per min 3,000
- Standard needle set 19 (3 mm)
- Av Air Con 4 cfm
- Weight 2.35 kg
- Vibration Level 2.3 m/sec<sup>2</sup>
- Sound Pressure 95.6 db(a)
- Length 370 mm
- Height 47 mm
- Air Inlet 1/4 bsp



## HP002PGLV

**LOW VIBRATION MEDIUM  
DUTY PISTOL NEEDLE SCALER**

Includes needle set (19 x 3 mm) part no.225

- Blows per min 2,400
- Standard needle set 19 (3 mm)
- Av Air Con 4 cfm
- Weight 2.7 kg
- Vibration Level 2.75 m/sec<sup>2</sup>
- Sound Pressure 90.7 db(a)
- Length 340 mm
- Height 172 mm
- Air Inlet 1/4 bsp





**HP001T**

**LIGHT DUTY STRAIGHT NEEDLE SCALER**

Includes needle set (12 x 3 mm) part no.125

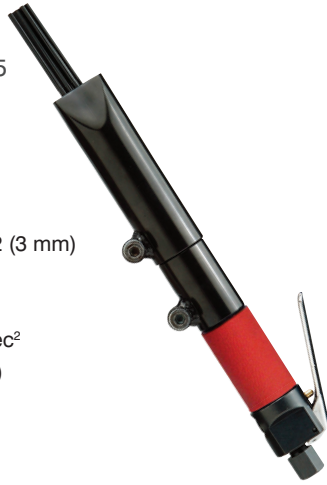

Blows per min 3,700  
Standard Needle Set 12 (3 mm)  
Av Air Con 3 cfm  
Weight 1.6 kg  
Vibration Level 8.5 m/sec<sup>2</sup>  
Sound Level 97.4 db(a)  
Length 350 mm  
Height 40 mm  
Air Inlet 1/4 bsp

**HP001**

**LIGHT DUTY STRAIGHT NEEDLE SCALER**

Includes needle set (12 x 3 mm) part no.125

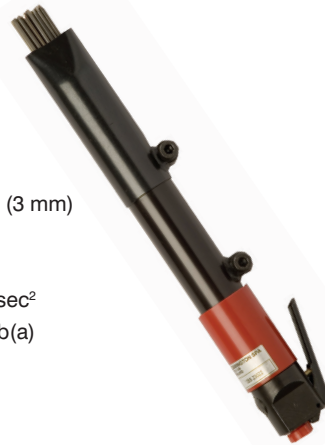

Blows per min 4,300  
Standard needle set 12 (3 mm)  
Av Air Con 15 cfm  
Weight 1.6 kg  
Vibration Level 13.8 m/sec<sup>2</sup>  
Sound Pressure 97.4 db(a)  
Length 360 mm  
Height 40 mm  
Air Inlet 1/4 bsp

**HP002T**

**MEDIUM DUTY STRAIGHT NEEDLE SCALER**

Includes needle set (19 x 3 mm) part no.225



Blows per min 2,700  
Standard needle set 19 (3 mm)  
Av Air Con 5.5 cfm  
Weight 2.5 kg  
Vibration Level 9.3 m/sec<sup>2</sup>  
Sound Pressure 100.3 db(a)  
Length 390 mm  
Height 47 mm  
Air Inlet 1/4 bsp

**HP002**

**MEDIUM DUTY STRAIGHT NEEDLE SCALER**

Includes needle set (19 x 3 mm) part no.225

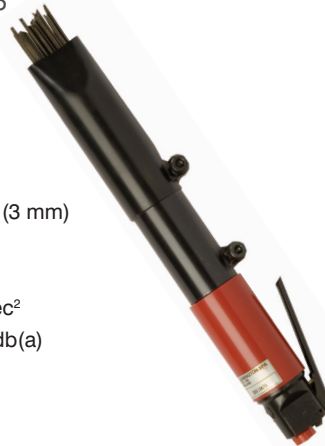

Blows per min 2,700  
Standard needle set 19 (3 mm)  
Av Air Con 5.5 cfm  
Weight 2.5 kg  
Vibration Level 9.3 m/sec<sup>2</sup>  
Sound Pressure 100.3 db(a)  
Length 390 mm  
Height 47 mm  
Air Inlet 1/4 bsp

**HP002PGT**

**MEDIUM DUTY PISTOL NEEDLE SCALER**

Includes needle set (19 x 3 mm) part no.225



Blows per min 3,000  
Standard Needle Set 19 (3 mm)  
Av Air Con 12 cfm  
Weight 2.7 kg  
Vibration Level 8.7 m/sec<sup>2</sup>  
Sound Level 97 db(a)  
Length 315 mm  
Air Inlet 1/4 bsp

**HP002PG**

**MEDIUM DUTY PISTOL NEEDLE SCALER**

Includes needle set (19 x 3 mm) part no.225



Blows per min 2,700  
Standard needle set 19 (3 mm)  
Av Air Con 5.5 cfm  
Weight 2.9kg  
Vibration Level 12.8 m/sec<sup>2</sup>  
Sound Pressure 100.3 db(a)  
Length 366 mm  
Height 172 mm  
Air Inlet 1/4 bsp



## NEEDLE SCALERS

### UT53NG

#### HEAVY DUTY PISTOL NEEDLE SCALER

Includes needle set (28 x 3 mm) part no.317



Blows per min 2,700  
Standard needle set 28 (3 mm)  
Av Air Con 8 cfm  
Weight 4.7 kg  
Vibration Level 18.6 m/sec<sup>2</sup>  
Sound Pressure 95.3 db(a)  
Length 339 mm  
Height 235 mm  
Air Inlet 1/4 bsp

### HP003

#### HEAVY DUTY PISTOL NEEDLE SCALER

Includes needle set (28 x 3 mm) part no.317



Blows per min 2,000  
Standard needle set 28 (3 mm)  
Av Air Con 8 cfm  
Weight 4.3 kg  
Vibration Level 12.2 m/sec<sup>2</sup>  
Sound Pressure 101.5 db(a)  
Length 460 mm  
Height 240 mm  
Air Inlet 1/4 bsp

### HP004

#### HEAVY DUTY PISTOL NEEDLE SCALER

Includes needle set (35 x 4 mm) part no.470F



Blows per min 1,800  
Standard needle set 35 (4 mm)  
Av Air Con 10 cfm  
Weight 5.9 kg  
Vibration Level 30.3 m/sec<sup>2</sup>  
Sound Pressure 104.4 db(a)  
Length 510 mm  
Height 265 mm  
Air Inlet 1/4 bsp

## ACCESSORIES

Larger carton quantities available for all types of needles



#### 3mm CHISEL TIP NEEDLE SETS

125 12 needles for #1 series  
225 19 needles for #2 series  
317 28 needles for #3 series



#### 3mm FLAT TIP NEEDLE SETS

1377 19 needles for #2 series

#### 3mm NON-SPARK BERYLLIUM

#### COPPER FLAT TIP NEEDLE SETS

317BC 28 needles for #3 series

#### 4mm FLAT TIP NEEDLE SETS

470F 35 needles for #4 series



POINTED TIP NEEDLE SETS ALSO AVAILABLE



# 13

## SPRAY GUNS

### UT57A

#### GENERAL PURPOSE SPRAY GUN

1.8 mm  
Suction feed

- Stainless steel 1.8 air cap set
- Air pressure 50 psi
- Av Air Con 9 cfm
- Weight 1.3 kg
- Length 157 mm
- Height With Pot 300 mm
- Cup Capacity 1 litre
- Air Inlet 1/4 bsp



### UT58A-14/UT58A-17

#### GRAVITY FEED SPRAY GUN

1.4 or 1.7 mm

- Stainless steel 1.4 or 1.7 air cap set
- Air pressure 40-70 psi
- Av Air Con 12 cfm
- Weight 0.72 kg
- Length 149 mm
- Height 313 mm
- Cup Capacity 600 ml
- Air Inlet 1/4 bsp



### UT59A

#### GRAVITY FEED TOUCH-UP GUN

1.0 mm

- Stainless steel
- 1.0 air cap set
- Air pressure 30-70 psi
- Av Air Con 13 cfm
- Weight 0.30 kg
- Length 100 mm
- Height With Pot 210 mm
- Cup Capacity 125 ml
- Air Inlet 1/4 bsp

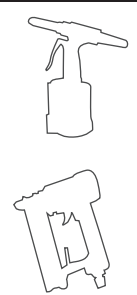



14

# RIVETERS



## HP130RN

### THREAD INSERT TOOL

Comes complete with mandrels:  
M3, M4, M5, M6, M8

Motor Speed 1,400 rpm

Stroke 7 mm

Vibration Level <2.5 m/sec<sup>2</sup>

Sound Pressure 72 db(a)

Length 278 mm

Height 317 mm

Weight 2.4 kg

Pull Force (at 85 psi) 2,167 kg

Av Air Con 4 cfm

Air Inlet 1/4 bsp

### MANDRILS FOR UT130RN

	Part No.
M3 - Mandril	42-M3
M4 - Mandril	42-M4
M5 - Mandril	42-M5
M6 - Mandril	42-M6
M8 - Mandril	42-M8
M10 - Mandril	42-M10
M12 - Mandril	42-M12





## UT40PPA

### 3/16" CAPACITY POP RIVET GUN

With rubber base plate and swivel joint (connector)

Traction Power 1,100 lbs  
 Av Air Con 2 cfm  
 Weight 1.5 kg  
 Nosepieces 3/32" (2.4 mm),  
 1/8" (3.2 mm), 5/32"  
 (4.0 mm), 3/16" (4.8 mm)  
 Vibration Level <2.5 m/sec<sup>2</sup>  
 Sound Pressure 77 db(a)  
 Length 270 mm  
 Width 98 mm  
 Rivet Capacity 3/32"-3/16"  
 Air Inlet 1/4 bsp



#### SPARE PARTS

106160 Nosepiece 3/32" - 2.4mm  
 107161 Nosepiece 1/8" - 3.2mm  
 107162 Nosepiece 5/32" - 4.0mm  
 107163 Nosepiece 3/16" - 4.8mm  
 107B07 Jaw Pusher  
 107B08 Jaw Set

## UT50PPA

### 1/4" AIR RIVETER

With rubber base plate and swivel joint (connector)

Traction Power 3,055 lbs  
 Stroke 14mm  
 Nose Pieces : 3/32"(2.4 mm),  
 1/8"(3.2 mm), 5/32"(4.0 mm)  
 3/16"(4.8 mm), 7/32"(5.6 mm)  
 1/4" (6.4 mm)  
 Av Air Con 2 cfm  
 Weight 1.97 kg  
 Vibration Level 0.2 m/sec<sup>2</sup>  
 Sound Level 78 db(a)  
 Air Inlet 1/4 bsp



#### SPARE PARTS

50PPA-1A Nosepiece 1/4" - 6.4mm  
 50PPA-1B Nosepiece 7/32" - 5.6mm  
 50PPA-1C Nosepiece 3/16" - 4.8mm  
 50PPA-1D Nosepiece 5/32" - 4.0mm  
 50PPA-1E Nosepiece 1/8" - 3.2mm  
 50PPA-1F Nosepiece 3/32" - 2.4mm  
 50PPA-08 Large Jaw Pusher for 1/4" to 3/16"  
 50PPA-07 Large Jaw Set for for 1/4" to 3/16"  
 50PPA-08A Small Jaw Pusher for 3/32" to 5/32"  
 50PPA-07A Small Jaw Set for 3/32" to 5/32"

## UT180R

### 1/4" POP RIVET GUN (VACUUM) KIT

Will pull stainless steel rivets and monobolts

Traction Power 3,700 lbs  
 Stroke 15 mm  
 Weight 1.95 kg  
 Nosepieces 1/8" (3.2 mm),  
 3/16" (4.8 mm), 5/32" (4.0  
 mm), 7/32" (5.6 mm), 1/4"  
 (6.4 mm)  
 Vibration Level <2.5 m/sec<sup>2</sup>  
 Sound Pressure 70.5 db(a)  
 Length 294 mm  
 Width 94 mm  
 Av Air Con 4 cfm  
 Air Inlet 1/4 bsp



#### SPARE PARTS

1800037 Nosepiece 1/4" - 6.4mm  
 1803701 Nosepiece 7/32" - 5.6mm  
 1803702 Nosepiece 3/16" - 4.8mm  
 1803703 Nosepiece 5/32" - 4.0mm  
 1803704 Nosepiece 1/8" - 3.2mm  
 1800041 Large Jaw Pusher for 1/4" to 3/16"  
 1800040 Large Jaw Set for for 1/4" to 3/16"  
 1804101 Small Jaw Pusher for 1/8" to 5/32"  
 1804001 Small Jaw Set for 1/8" to 5/32"



15

# MISCELLANEOUS

## UT616BN

### COMPOSITE WINDSCREEN CUTTER

Complete with one straight blade CF-K01A-BC

VARIABLE BLADE POSITION

COMPOSITE COMFORT GRIP

SAFETY THROTTLE LEVER

REAR EXHAUST



- Cutting Oscillation 20,000 rpm
- Av Air Con 4 cfm
- Weight 0.97 kg
- Vibration Level 3.8 m/sec<sup>2</sup>
- Sound Level 86 db(a)
- Length 195 mm
- Air Inlet 1/4 bsp

A/B	C/D/E/F	G	

**WINDSCREEN CUTTER BLADES**

Fig..	Description
A	Straight blade - 57mm CF-K01A-BC
B	Straight blade - 90mm CF-K01B-BC
C	Hook blade - 18mm CF-K02A-BC
D	Hook blade - 36mm CF-K02B-BC
E	Hook blade - 63mm CF-K02C-BC
F	Hook blade - 90mm CF-K02D-BC
G	Offset blade - 30mm CF-K03-BC
H	Straight blade - 8mm CF-K04-BC
J	Blade - 35mm CF-K05-BC
K	Hook blade - 24mm CF-K08-BC
L	Circular blade DCA-25





## HP0026

### BLOW GUN

The highest quality, most durable blow gun on the market

Robust and impact resistant, infinitely adjustable, leak-free & unblockable

Air Flow 380 L/min at 8 bar (115 psi)

Sound Level 85 db(a) at 8 bar (115 psi)

Operating Temperature -10°C to +80°C

Max Pressure 16 bar (230 psi)

SAFETY BLOWGUN:  
UNBLOCKABLE

SUPERIOR AIR FLOW  
OF 380 L/MIN

USER-FRIENDLY ERGONOMIC DESIGN WITH SPECIAL VALVE SYSTEM FOR EASY AND PRECISE USE

## TOOL BALANCERS

Other balancers available on request



Balancer	From (kg)	To (kg)	Cable (mm)
SB-3000	1.5	3.0	1,500
T-9311	0.4	1.0	1,600
T-9312	1.0	2.0	1,600
T-9313	2.0	3.0	1,600
T-9336	2.0	4.0	2,500
T-9337	4.0	6.0	2,500
T-9338	6.0	8.0	2,500
T-9339	8.0	10.0	2,500
T-9340	10.0	14.0	2,500



### UT176RLW ENGRAVING PEN

Supplied with tungsten-tipped  
medium engraving needle

Replacement  
needles (tip size)  
Thin RL10013  
Medium RL10014  
Thick RL10015

Av Air Con 2 cfm	Length 137 mm
Weight 0.25 kg	Height 19 mm
Vibration Level <2.5 m/sec <sup>2</sup>	Air Inlet 1/4 bsp
Sound Pressure 74.8 db(a)	



### UT200A SPOT WELD CUTTER

8mm cutter use part number  
SD-80041A

Av Air Con 4 cfm
Weight 1.6 kg
Vibration Level <2.5 m/sec <sup>2</sup>
Sound Pressure 95.0 db(a)
Speed 1,200 rpm
Length 304 mm
Height 49 mm
Air Inlet 1/4 bsp



### UT021A STAPLE GUN

For staples  
use part no.  
UT021 + length  
required  
e.g. UT021A-6  
for 6mm

Crown size 10 mm
Staple lengths 6,10,13,16,19 & 22 mm
Av Air Con 3 cfm
Weight 1.1 kg
Vibration Level 2.8 m/sec <sup>2</sup>
Sound Pressure 83.1 db(a)
Length 202 mm
Height 177 mm
Air Inlet 1/4 bsp





## UT100R CAULKING GUN

Takes a standard 310mm cartridge (Longer 380mm cartridge also available)  
With flow regulator

Av Air Con 4 cfm  
Weight 1.9 kg  
Vibration Level <2.5 m/sec<sup>2</sup>  
Operating pressure 30-60 psi  
Tube size 215 mm x 50 mm  
Length 272 mm  
Height 145 mm  
Air Inlet 1/4 bsp



## UT395 AIR VACUUM KIT

High performance composite gun body with vacuum/  
blow two way function  
Attachments: Brush, small diameter vacuum tube,  
extention tube, flat tube, flexible hose

Av Air Con 3.36 cfm  
Weight 0.67 kg  
Vibration Level <2.5 m/sec<sup>2</sup>  
Sound Pressure 92.0 db(a)  
Length 140 mm  
Height 132 mm  
Air inlet 1/4 bsp



## UT397 CONTINUOUS FLOW GREASE GUN

Will take cartridges/sausage bags, or self fill

Av Air Con 2 cfm  
Weight 1.6 kg  
Vibration Level <2.5 m/sec<sup>2</sup>  
Cartridge cap 400 ml (14 oz)  
Working Pressure 40-100 psi  
Out Pressure 3,800 psi  
Flex Hose 240 mm  
Fix Hose 164 mm  
Air Inlet 1/4 bsp





# 16

## TOOL OIL

### MARVEL

UNIVERSAL AIR TOOLS HAS RECOMMENDED MARVEL AIR TOOL OIL FOR OVER 30 YEARS.

- Provides positive lubrication for smooth starting
- Dissolves the deposits that cut down tool speed and reduce power output
- Prevents rust formation
- Assures maximum performance
- Lengthens the life of your tools

#### Part Numbers

H0076	Small bottle 4 US fl. oz. (118ml)
H0075	Case of 48 small bottles
H0077	Large bottle 32 US fl. oz. (946ml)
H0078	Case of 12 large bottles

Silicone free  
ISO Grade 10  
Freezing point: -51 °C  
Flashpoint: +51 °C



Marvel's unique formulation has a heavy-duty corrosion inhibitor to protect your Universal Tool from moisture in the air line. It includes a solvent that breaks down deposits and gum, allowing them to be safely blown out of the exhaust, leaving a lasting coating of oil for lubrication and your air tool in peak condition. This oil is silicone free and protects the o-rings, seals and other plastic parts.

# HOSES, COUPLINGS & REGULATORS

# 17



## AH1015PVCREEL

Ideal for automotive workshops

10mm (3/8") ID x 15m long  
1/4" BSP M threaded fittings  
Automatic or free running  
Highly durable composite case  
Steel mounting bracket



## AH1315RREEL

Ideal for commercial vehicle workshops and industrial applications

13mm (1/2") ID x 15m long  
1/2" BSP M & F threaded fittings  
Highest quality rubber hose  
Automatic or free running  
Reinforced steel housing



## AH1015RREEL

Ideal for commercial vehicle workshops and industrial applications

10mm (3/8") ID x 15m long  
1/4" BSP M & F threaded fittings  
Highest quality rubber hose  
Automatic or free running  
Reinforced steel housing



## RUBBER WHIP HOSE

Recommended to isolate the vibration at the air tool from the quick coupling and prevent accidents

All supplied with male & female threaded fittings

AH08RWHIP - 8mm ID x 0.5m with 1/4" BSP  
AH10RWHIP - 10mm ID x 0.5m with 1/4" BSP  
AH13RWHIP - 13mm ID x 0.5m with 1/2" BSP

## RUBBER ALLOY, RUBBER & HIGH VIZ RUBBER HOSE

Working Pressure 290 PSI (20 Bar)  
Burst Pressure 870 PSI (60 Bar)  
Temperature Range -20°C to +70°C  
100% Silicone Free  
Oil & Abrasion Resistant



Rubber Alloy	Rubber	High Viz	Hose ID	Length	Fitting A	Fitting B
AH0805RA	AH0805R	AH0805HV	8mm	5m	1/4" BSP Male	1/4" BSP Male
AH0810RA	AH0810R	AH0810HV	8mm	10m	1/4" BSP Male	1/4" BSP Male
AH0815RA	AH0815R	AH0815HV	8mm	15m	1/4" BSP Male	1/4" BSP Male
AH0820RA	AH0820R	AH0820HV	8mm	20m	1/4" BSP Male	1/4" BSP Male
		AH0910HVFL	9mm	10m	1/4" BSP Male	1/4" BSP Male
		AH0915HVFL	9mm	15m	1/4" BSP Male	1/4" BSP Male
		AH0920HVFL	9mm	20m	1/4" BSP Male	1/4" BSP Male
		AH0930HVFL	9mm	20m	1/4" BSP Male	1/4" BSP Male
AH1005RA	AH1005R	AH1005HV	10mm	5m	1/4" BSP Male	1/4" BSP Male
AH1010RA	AH1010R	AH1010HV	10mm	10m	1/4" BSP Male	1/4" BSP Male
AH1015RA	AH1015R	AH1015HV	10mm	15m	1/4" BSP Male	1/4" BSP Male
AH1020RA	AH1020R	AH1020HV	10mm	20m	1/4" BSP Male	1/4" BSP Male
AH1305RA	AH1305R	AH1305HV	13mm	5m	1/2" BSP Male	1/2" BSP Female
AH1310RA	AH1310R	AH1310HV	13mm	10m	1/2" BSP Male	1/2" BSP Female
AH1315RA	AH1315R	AH1315HV	13mm	15m	1/2" BSP Male	1/2" BSP Female
AH1320RA	AH1320R	AH1320HV	13mm	20m	1/2" BSP Male	1/2" BSP Female



## SPRAY BOOTH RUBBER HOSE

High Temperature Rubber (Blue)  
Air hose with 1/4" BSP male fittings  
Temperature range -40 °C to +100 °C  
AH1010RHT 10mm ID x 10m  
AH1015RHT 10mm ID x 15m



## COILED AIR HOSE

Supplied with 1/4" BSP male fittings  
8mm ID M0208C (2m) & M0508C (5m)  
10mm ID M0210C (2m) & M0510C (5m)  
13mm ID M6513C (6.5m) 3/8" BSP female



## CLEAR REINFORCED PVC HOSE

Available in 6mm, 8mm, 10mm and 13mm ID  
30m lengths without fittings



### FILTERS, REGULATORS & LUBRICATORS

A modular, compact, low weight and robust range of solutions to suit all applications

	Industrial Series 25 micron filter		Automotive Series 40 micron filter	
	3/8"	1/2"	3/8"	1/2"
"Filter/Regulator/Lubricator (Semi Auto Drain)"	SAD38	SAD12	SAD38N	SAD12N
Filter/Regulator	FR38M	FR12M	FR38MN	FR12MN
Filter Only	F38	F12	Not sold separately	
Regulator Only & Gauge	R38	R12	Not sold separately	
Lubricator Only	L38	L12	Not sold separately	
Replacement Gauge	H0013	H0013	H0013N	H0013N



#### 1/4" BSP STANDARD SERIES



**Adaptor**  
Male SA38N Female SA38FN



**Quick Coupling**  
Male CU38-MN Female CU38N

#### 1/4" BSP SUPER FLOW SERIES



**Adaptor**  
Male SA38NSF Female SA38FNSF



**Quick Coupling**  
Male CU38-MNSF Female CU38NSF

#### 3/8" BSP 1/2" BSP 100 SERIES



**Adaptor**  
Male 3/8" BSP SA12 1/2" BSP SA1212



**Quick Coupling**  
Female CU100F CU1212

#### CU38-YN Y-Piece



#### H01415 1/4" BSP Swivel Coupling with Gauge



#### INTEGRAL TAILPIECES

IT38N 10mm ID to Standard Adaptor  
IT12 13mm ID to 100 Series



#### TAILPIECES

TP14 6mm ID to 1/4" BSP  
 TP38N 10mm ID to 1/4" BSP  
 TP12 13mm ID to 3/8" BSP  
 TP1212 13mm ID to 1/2" BSP



# INFORMATION

## UNIVERSAL TOOL (UT) & AIRCAT BRANDS:

Since the mid 1970's Florida Pneumatic Manufacturing Corporation in North America; and Universal Air Tool Company Limited in Europe have both based their own brand air tool business on the Universal Tool (UT) brand.

In North America the UT brand has been primarily directed at the industrial market, while in Europe the UT brand has been directed at both the Industrial & Automotive Aftermarket.

In July 2014 Florida Pneumatic absorbed AIRCAT into its business portfolio. This followed the acquisition of AIRCAT by the group's parent company P & F Industries. In October 2014 the AIRCAT brand was introduced to Europe via Universal Air Tool Company Limited.

P & F Industries, Florida Pneumatic Manufacturing Corporation and Universal Air Tool Company Limited, will continue to focus on and further develop the UT brand which is the foundation of our group's air tool business. The AIRCAT brand adds a valuable element to ensure that the group and its subsidiary companies can better compete at the top end of the Automotive Aftermarket with certain other leading brands of high performance air tools; primarily marketed to the global Automotive Aftermarket.

## ONE YEAR LIMITED WARRANTY

Universal Air Tool Company Limited warrants its tools to be free from defects in materials and workmanship. Tools thought to be defective should be returned to head office or an authorised service centre, transportation charges prepaid, for examination and consequent repair or replacement. This warranty does not cover damage to tools arising from alteration, abuse, or use for other than their intended purpose and does not cover any repairs or replacement made by anyone other than Universal Air Tool Company or its authorised repair centres.

The duration of the warranty and any other warranty including, but not limited to, any implied warranty of merchantability is expressly limited to one year, beginning from the date of the delivery to the original user. The obligation of Universal Air Tool Company Limited under any warranty, express or implied, is limited solely to the repair or replacement at its head office or authorised repair centre of any part which shall prove defective. The rights under this warranty are limited to the original user and may not be transferred to subsequent owners.

## BEST PRACTICE

Use a clean lubricated air supply that will give a measured air pressure at the tool of 90 psi (6.2 bar) when the tool is running with the trigger fully depressed and the air regulator in its maximum opening flow position. Use recommended hose size and length. It is recommended that the tool is connected to the air supply as shown. Do not connect an adaptor directly to the tool but use a whip or leader hose of approximately 50cm (20") in length. Do not connect the tool to the air line system without incorporating an easy to reach and operate air shut-off valve. The air supply should be lubricated. It is strongly recommended that an air filter, regulator, lubricator (FRL) is used as this will supply clean, lubricated air at the correct pressure to the tool. Use suitable pneumatic motor lubricating oil, preferably incorporating a rust inhibitor. UT recommends Marvel Air Tool Oil.

If a lubricator is not used then the tool should be lubricated by shutting off the air supply to the tool and depressurising the line by pressing the trigger on the tool. Disconnect the air line and pour into the intake bushing a teaspoonful (5ml) of oil. Reconnect the tool to the air supply and run the tool slowly for a few seconds to allow air to circulate the oil. If the tool is used frequently then lubricate on a daily basis, also if the tool starts to slow or lose power. When lubricating, ensure that the screen is clean.

It is recommended that the air pressure at the tool whilst the tool is running is 90 psi (6.2 bar). The tool can run at lower and higher pressures with a maximum permitted working air pressure of 100 psi (7.0 bar). For a lower air pressure the tool will give a lower output for a given setting of the air regulator set for 90 psi operation and an increased output for higher pressures. Always read the tool instructions for specific information that may overrule this general best practice.

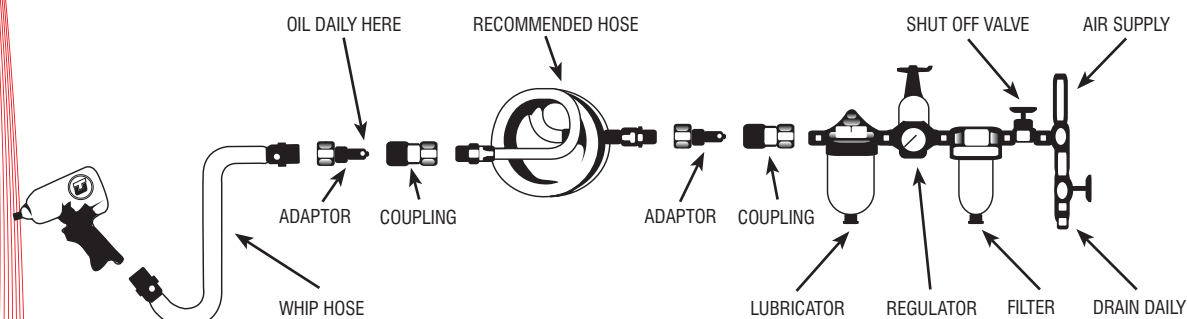



## USEFUL MEASUREMENTS

### INS - MM

Ins	mm	11/32	8.731	11/16	17.642
1/64	0.397	23/64	9.128	45/64	17.859
1/32	0.794	3/8	9.525	23/32	18.256
3/64	1.191	25/64	9.922	47/64	18.653
1/16	1.588	13/32	10.319	3/4	19.050
5/64	1.984	27/64	10.719	49/64	19.447
3/32	2.381	7/16	11.112	51/64	20.241
7/64	2.778	29/64	11.509	13/16	20.638
1/8	3.175	15/32	11.906	53/64	21.034
9/64	3.572	31/64	12.303	27/32	21.431
5/32	3.969	1/2	12.700	55/64	21.828
11/64	4.366	33/64	13.097	7/8	22.225
3/16	4.762	17/32	13.494	57/64	22.622
13/64	5.159	35/64	13.891	29/32	23.019
7/32	5.556	9/16	14.288	59/64	23.416
15/64	5.953	37/64	14.684	15/16	23.812
1/4	6.350	19/32	15.081	61/64	24.209
17/64	6.747	39/64	15.478	31/32	24.606
9/32	7.143	5/8	15.875	63/64	25.003
19/64	7.541	41/64	16.272	1	25.400
5/16	7.938	21/32	16.669		
21/64	8.334	43/64	17.066		

### TORQUE

Ft-lb	Kg-m	N-m	1,600	221.28	2169.31
200	27.66	271.16	1,650	228.20	2237.10
250	34.58	338.96	1,700	235.11	2304.89
300	41.49	406.75	1,750	242.03	2372.69
350	48.41	474.54	1,800	248.94	2440.48
400	55.32	542.33	1,850	255.86	2508.27
450	62.24	610.12	1,900	262.77	2576.06
500	69.15	677.91	1,950	269.69	2643.85
550	76.07	745.70	2,000	276.60	2711.64
600	82.98	813.49	2,050	283.52	2779.43
650	89.90	881.28	2,100	290.43	2847.22
700	96.81	949.07	2,150	297.35	2915.01
750	103.73	1016.87	2,200	304.26	2982.80
800	110.64	1084.66	2,250	311.18	3050.60
850	117.56	1152.45	2,300	318.09	3118.39
900	124.47	1220.24	2,350	325.01	3186.18
950	131.39	1288.03	2,400	331.92	3253.97
1,000	138.30	1355.82	2,450	338.84	3321.76
1,050	145.22	1423.61	2,500	345.75	3389.55
1,100	152.13	1491.40	2,550	352.67	3457.34
1,150	159.05	1559.19	2,600	359.58	3525.13
1,200	165.96	1626.98	2,650	366.50	3592.92
1,250	172.88	1694.78	2,700	373.41	3660.71
1,300	179.79	1762.57	2,750	380.33	3728.51
1,350	186.71	1830.36	2,800	387.24	3796.30
1,400	193.62	1898.15	2,850	394.16	3864.09
1,450	200.54	1965.94	2,900	401.07	3931.88
1,500	207.45	2033.73	2,950	407.99	3999.67
1,550	214.37	2101.52	3,000	414.90	4067.46

### TORQUE

n.m	kg-m	kg-cm	ft-lb	lb-in
0.0980665	0.01	1	0.07233	0.8677
1	0.101972	10.1972	0.73756	8.8507
1.35582	0.1383	13.83	1	12
9.80665	1	100	7.233	86.77

### AIR PRESSURE

bar	psi
10	145
1	14.5
6.2	90
0.9807	14.223
0.0689	1

### WEIGHT

Lb	kg
1	0.45359
2.20462	1

### LENGTH

m	in	ft
1	39.371	3.2809
0.3048	12	1
0.0254	1	0.08333





Model	Pg	Model	Pg	Model	Pg
HP001	43	UT5922LV	38	UT8740A10	29
HP001T	43	UT5964A	19	UT8740A14	29
HP002	43	UT59A	45	UT8740B14	29
HP0026	49	UT616BN	48	UT8740C14	29
HP002LV	42	UT8000REA	5	UT8749S	25
HP002PG	43	UT8000REB	5	UT8750-T	30
HP002PGLV	42	UT8000S14	5	UT8752	28
HP002PGT	43	UT8000S38	4	UT8756-1	25
HP002T	43	UT8001R	7	UT8766	30
HP003	44	UT8004	5	UT8771A	25
HP003LV	42	UT8011R	6	UT8775-ABK	33
HP004	44	UT8025R-1	9	UT8776KIT	23
HP020	39	UT8026	9	UT8777	26
HP130RN	46	UT8030RA	9	UT8777C	30
HP144	9	UT8070P-1	9	UT8777CBK	26
HP17RD	17	UT8070R-1	9	UT8779A	30
HP180LI	11	UT8125	9	UT8780K	30
UT010	24	UT8126	10	UT8794	24
UT021A	50	UT8126K	10	UT8795	24
UT100R	51	UT8138	10	UT8795-DC	24
UT150	12	UT8175R	10	UT8799V	23
UT176RLW	50	UT8176	8	UT8806	16
UT180R	47	UT8226	20	UT8817	15
UT2005-1	5	UT8326	11	UT8817-S	19
UT2005H-1	7	UT8340C-2	11	UT8818	17
UT200A	50	UT8360C-1	11	UT8818-S	19
UT2147R-1	10	UT8419	12	UT8821	15
UT2780-1	23	UT8419S	12	UT8833R-1	15
UT2815R	15	UT8420	12	UT8840R-1	17
UT2855R	14	UT8420S	12	UT8841	15
UT2855R-7	16	UT8468	12	UT8841-DG	32
UT2960A	19	UT8468S	12	UT8841-S	41
UT2964A	19	UT8468AH	12	UT8841-SM	28
UT3	23	UT8468AHS	12	UT8860R-1	16
UT395	51	UT8470C	12	UT8905	21
UT397	51	UT8600-1	41	UT8906	21
UT40PP-A	47	UT8606	41	UT8955-1	21
UT50PP-A	47	UT8631BK	36	UT8956	21
UT5315	11	UT8646-1	35	UT8957	20
UT53NG	44	UT8646-1BK	35	UT8958	20
UT5710B	31	UT8654H4	36	UT8959	20
UT5715	30	UT8663	35	UT8960-1	21
UT5720B	31	UT8664	35	UT8961-1	21
UT5721	32	UT8674-1	36	UT8961NR	7
UT5721-TB	32	UT8706K-2	32	UT8962	20
UT5735	31	UT8707	32	UT8963	18
UT5742D	16	UT8707K	32	UT919C	31
UT5761A	40	UT8708	22	UT9704	24
UT5762	41	UT8709	23	UT9750	30
UT5766	25	UT8709-DC	23	UT9750A	30
UT57A	45	UT8716-BKC	33	UT9750B	30
UT5825	15	UT8724	32	UT9764	24
UT5825-S	19	UT8724-12	31	UT9765	24
UT58A-14	45	UT8724-20	31	UT9925BK	35
UT58A-17	45	UT8724T-20	31		
UT5920	39	UT8728E	31		





A series of horizontal lines for taking notes, spanning most of the page width.



# **AIRCAT** **PNEUMATIC TOOLS**®

For even more latest design high performance Automotive Service Tools ask for our AIRCAT catalog

Distributed by

Information, orders & expert advice: Call 01494 883300 | Email [sales@universal.co.uk](mailto:sales@universal.co.uk)